

ADLEEPOWER®

# INSTRUCTION MANUAL

## GENERAL-PURPOSE INVERTER



**THANK YOU VERY MUCH FOR YOUR PURCHASE  
OF ADLEE INVERTER AS SERIES.  
PLEASE READ THIS INSTRUCTION MANUAL  
BEFORE INSTALLATION OF THE INVERTER.**

## PREFACE

This general-purpose inverter made by ADLEE Powertronic., Ltd. Read this instruction manual thoroughly before operation.

This manual will be helpful in the installation, parameter setting, troubleshooting, and daily maintenance of the AC motor drives. To guarantee safe operation of the equipment, read the following safety guidelines before connecting power to the AC drives. Keep this operating manual handy and distribute to all users for reference.

### A. General Precaution

1. There are some covers and shields on this inverter.  
Make sure all covers and shields are replaced before operating this product.
2. This manual may be modified when necessary because of improvement of the product or changes in specification.
3. Contact your ADLEE representative to order a copy of this manual, if your manual has been damaged or lost.
4. ADLEE is not responsible for any modification of the product made by the user, since that will void your guarantee.

### B. Safety symbols

Symbols which may appear on the manual

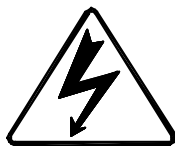

#### WARNING

Indicates a potentially hazardous situation which, if not avoided, could result in death or serious injury to personnel.



#### CAUTION

Indicates a potentially hazardous situation which, if not avoided, may result in minor or moderate injury to personnel and damage to equipment.

---

## RECEIVING

---

### CAUTION

- \* Do not install or operate the driver which is damaged or has missing parts.  
Failure to observe this caution may result in personal injury or equipment damage.
- 

## INSTALLATION

---



### CAUTION

- \* Lift the cabinet by the base. When moving the unit, never lift by the front cover.  
Otherwise, the main unit may be dropped causing damage to the unit.
  - \* Mount the driver on nonflammable material. (i.e. metal)  
Failure to observe this caution can result a fire.
  - \* When mounting units in an enclosure, install a fan or other cooling device to keep the intake air temperature below 45 °C.  
Overheating may cause a fire or damage to the unit.
- 

## INSTALLATION

---

### WARNING

- \* Only commence wiring after verifying that the power supply is turned OFF.  
Failure to observe this warning can result in an electrical shock or a fire.
- \* Wiring should be performed only by qualified personnel.  
Failure to observe this warning can result in an electrical shock or a fire.
- \* Make sure to ground the ground terminal.  
Ground resistance : 100 Ohm or less.  
Failure to observe this warning can result in an electrical shock or a fire.

## CAUTION

- \* Verify that the driver rated voltage coincides with the AC power supply voltage.  
Failure to observe this caution can result in personal injury or a fire.
- \* Do not perform a withstand voltage test of the driver.  
It may cause semi-conductor elements to be damaged.
- \* To connect a braking resistor, follow in APPENDIX A.  
Improper connection may cause the unit damaged or a fire.
- \* Tighten terminal screws.  
Failure to observe this caution can result a fire.
- \* Never connect the AC main circuit power supply to output terminals U, V and W.  
The inverter will be damaged and invalidate the guarantee.

---

## OPERATION

---



### WARNING

- \* Only turn ON the input power supply after replacing the front cover.  
Do not remove the cover while current is flowing.  
Failure to observe this warning can result in an electrical shock.



## CAUTION

- \* Since it is easy to change operation speed from low to high speed, verify the safe working range of the motor and machine before operation.  
Failure to observe this caution can result in personal injury and machine damage.
- \* Do not change signals during operation.  
The machine or the inverter may be damaged.
- \* All the constants of the inverter have been preset at the factory.  
Do not change the settings unnecessary.

---

## MAINTENANCE AND INSPECTION

---

### WARNING

- \* Never touch high-voltage terminals in the driver.  
Failure to observe this warning can result in an electrical shock.
- \* Replace all protective covers before powering up the inverter.  
To remove the cover, make sure to shut OFF the molded-case circuit breaker.  
Failure to observe this warning can result in an electrical shock.
- \* Perform maintenance or inspection only after verifying that the CHARGE LED goes OFF, after the main circuit power supply is turned OFF.  
The capacitors are still charged and can be dangerous.
- \* Only authorized personnel should be permitted to perform maintenance, inspections or parts replacement.  
Failure to observe this warning can result in an electrical shock.

## **CAUTION**

- \* The control PC board employs CMOS ICs. Do not touch the CMOS elements by hand.  
They are easily damaged by static electricity.
- \* Do not connect or disconnect wires or connectors while power is applied to the circuit.  
Failure to observe this caution can result in personal injury.

---

## **OTHERS**

---



### **WARNING**

- \* Never modify the product.  
Failure to observe this warning can result in an electrical shock or personal injury and will invalidate the guarantee.

# CONTENTS

|  |    |
|--|----|
| 1. RECEIVING .....                     | 1  |
| 2. SPECIFICATIONS .....                | 2  |
| 3. DIMENSION DRAWINGS .....            | 4  |
| 4. INSTALLATION .....                  | 7  |
| 5. DESCRIPTION OF TERMINALS .....      | 9  |
| 6. DIGITAL OPERATION PANEL .....       | 15 |
| 7. FUNCTIONS DESCRIPTION .....         | 16 |
| 8. DISPLAY ERROR CODES .....           | 53 |
| 9. HARDWARE PROTECTIVE FUNCTIONS ..... | 56 |
| 10. PRECAUTIONS .....                  | 57 |
| 11. TROUBLESHOOTING .....              | 58 |
| 12. APPLICATION .....                  | 59 |
| 13. INVERTER SELECTION .....           | 63 |
| 14. APPENDIX .....                     | 65 |
| A. Optional braking resistor .....     | 65 |
| B. Terminal wiring diagram .....       | 66 |
| C. Remote operator .....               | 68 |

# 1. RECEIVING

This AS series AC drive has gone through rigorous quality control tests at the factory before shipment. After receiving the AC drive, please check for the following :

- (1) No damage is found on each product after shipping.
- (2) The product is as ordered (check the nameplate, voltage and frequency).
- (3) A set of inverter unit and instruction manual is contained in the package.

For any irregularity, contact the sales shop where you purchased immediately.

- (4) Description of name plate

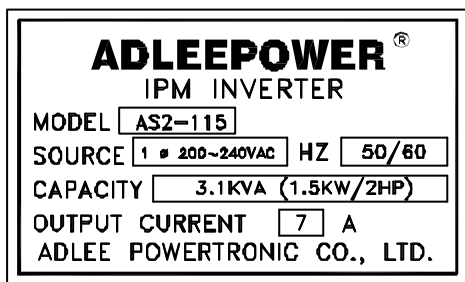

MODEL : AS 2 - 115 R

AS series

Voltage class :  
 1 : 110V  
 2 : 200~240V  
 4 : 380/440V

R : REMOTE CONTROL SERIES  
 H : HIGH SPEED SERIES

Max Applicable motor(4 pole)

Single Phase :

104 : 0.4KW    107 : 0.75KW    115 : 1.5KW  
 122 : 2.2KW    137 : 3.7KW





3 Phase :

304 : 0.4KW    307 : 0.75KW    315 : 1.5KW  
 322 : 2.2KW    337 : 3.7KW







## 2. SPECIFICATIONS

### (1) Single phase input port

| Model                        | AS1   |   | AS2                    |             |            |            |            |
|------------------------------|---|---|------------------------|-------------|------------|------------|------------|
| Voltage                      | 1 110VAC $\pm$ 10%                          |   | 1 200~240VAC $\pm$ 10% |             |            |            |            |
| Model No                     | AS1-104                                     | AS1-107   | AS2-104                | AS2-107     | AS2-115    | AS2-122    | AS2-137    |
| Input Frequency              | 50HZ ~ 60HZ $\pm$ 10%                       |   |                        |             |            |            |            |
| Output Voltage               | 3 220VAC                                    |   |                        |             |            |            |            |
| Output Frequency             | 0.5 ~ 400HZ / 0.5 ~ 2400HZ (High frequency) |   |                        |             |            |            |            |
| Output Rated current (A)     | 2.5 A                                       | 4.1 A   | 2.5 A                  | 4.1 A       | 7 A        | 10 A       | 16 A       |
| Capacity (KVA)               | 1.0 KVA                                     | 1.6 KVA   | 1.0 KVA                | 1.6 KVA     | 2.7 KVA    | 3.8 KVA    | 6.1 KVA    |
| Largest motor KW ( 4 poles ) | 0.4KW                                       | 0.75KW  | 0.4KW                  | 0.75KW      | 1.5KW      | 2.2KW      | 3.7KW      |
| Control                      | Sine wave pulse width modulation            |   |                        |             |            |            |            |
| Braking                      | Regenerative discharge braking              |   |                        |             |            |            |            |
| Over current Capacity        | 150% of rated current ( 1 minute)           |   |                        |             |            |            |            |
| Acceleration time            | 0.1 ~ 6000 SEC                              |   |                        |             |            |            |            |
| Deceleration time            | 0.1 ~ 6000 SEC                              |   |                        |             |            |            |            |
| Frequency setting            | Digital                                     | Use keyboard    for setting and confirm by  |                        |             |            |            |            |
|                              | Analog                                      | By frequency knob   |                        |             |            |            |            |
| Display type                 | LED Digits                                  |   |                        |             |            |            |            |
| Cooling Method               | Self-cooled                                 | Air-cooled  | Self-cooled            | Self-cooled | Air-cooled | Air-cooled | Air-cooled |
| Dimension drawing            | Fig 1                                       | Fig 2   | Fig 1                  | Fig 1       | Fig 2      | Fig 2      | Fig 3      |
| Weight ( NW . KG )           | 1.2KG                                       | 1.3KG   | 1.2KG                  | 1.3KG       | 1.3KG      | 1.4KG      | 4.2KG      |

Note : AS2-107 for special use, dimension drawing refer to Fig2.

## (2) 3 Phase input port

|                              |   |   |            |            |            |                        |            |            |            |
|------------------------------|---|---|------------|------------|------------|------------------------|------------|------------|------------|
| Model                        | AS2   |   |            |            |            | AS4                    |            |            |            |
| Voltage                      | 3 200-240VAC $\pm$ 10%                      |   |            |            |            | 3 380/440VAC $\pm$ 10% |            |            |            |
| Model No                     | AS2-304                                     | AS2-307   | AS2-315    | AS2-322    | AS2-337    | AS4-307                | AS4-315    | AS4-322    | AS4-337    |
| Input Frequency              | 50HZ ~ 60HZ $\pm$ 10%                       |   |            |            |            |                        |            |            |            |
| Output Voltage               | 3 220VAC                                    |   |            |            |            | 3 380/440VAC           |            |            |            |
| Output Frequency             | 0.5 ~ 400HZ / 0.5 ~ 2400HZ (High frequency) |   |            |            |            |                        |            |            |            |
| Output Rated current (A)     | 3 A   | 5 A   | 8 A        | 11 A       | 17 A       | 2.5 A                  | 4 A        | 6 A        | 9 A        |
| Capacity (KVA)               | 1.1 KVA                                     | 1.9 KVA   | 3.1 KVA    | 4.2 KVA    | 6.5 KVA    | 1.9 KVA                | 3.1 KVA    | 4.2 KVA    | 6.9 KVA    |
| Largest motor KW ( 4 poles ) | 0.4 KW                                      | 0.75 KW   | 1.5 KW     | 2.2 KW     | 3.7 KW     | 0.75 KW                | 1.5 KW     | 2.2 KW     | 3.7 KW     |
| Control                      | Sine wave pulse width modulation            |   |            |            |            |                        |            |            |            |
| Braking                      | Regenerative discharge braking              |   |            |            |            |                        |            |            |            |
| Over current Capacity        | 150% of rated current ( 1 minute)           |   |            |            |            |                        |            |            |            |
| Acceleration time            | 0.1 ~ 6000 SEC                              |   |            |            |            |                        |            |            |            |
| Deceleration time            | 0.1 ~ 6000 SEC                              |   |            |            |            |                        |            |            |            |
| Frequency setting            | Digital                                     | Use keyboard    for setting and confirm by  |            |            |            |                        |            |            |            |
|                              | Analog                                      | By frequency knob   |            |            |            |                        |            |            |            |
| Display type                 | LED Digits                                  |   |            |            |            |                        |            |            |            |
| Cooling Method               | Self-cooled                                 | Self-cooled   | Air-cooled | Air-cooled | Air-cooled | Air-cooled             | Air-cooled | Air-cooled | Air-cooled |
| Dimension drawing            | Fig 1                                       | Fig 1   | Fig 2      | Fig 2      | Fig 3      | Fig 2                  | Fig 2      | Fig 2      | Fig 3      |
| Weight ( NW . KG )           | 1.2 KG                                      | 1.3 KG  | 1.3 KG     | 1.4 KG     | 4.2 KG     | 1.3 KG                 | 1.3 KG     | 4.0 KG     | 4.0 KG     |

### 3. DIMENSION DRAWINGS

Unit : mm

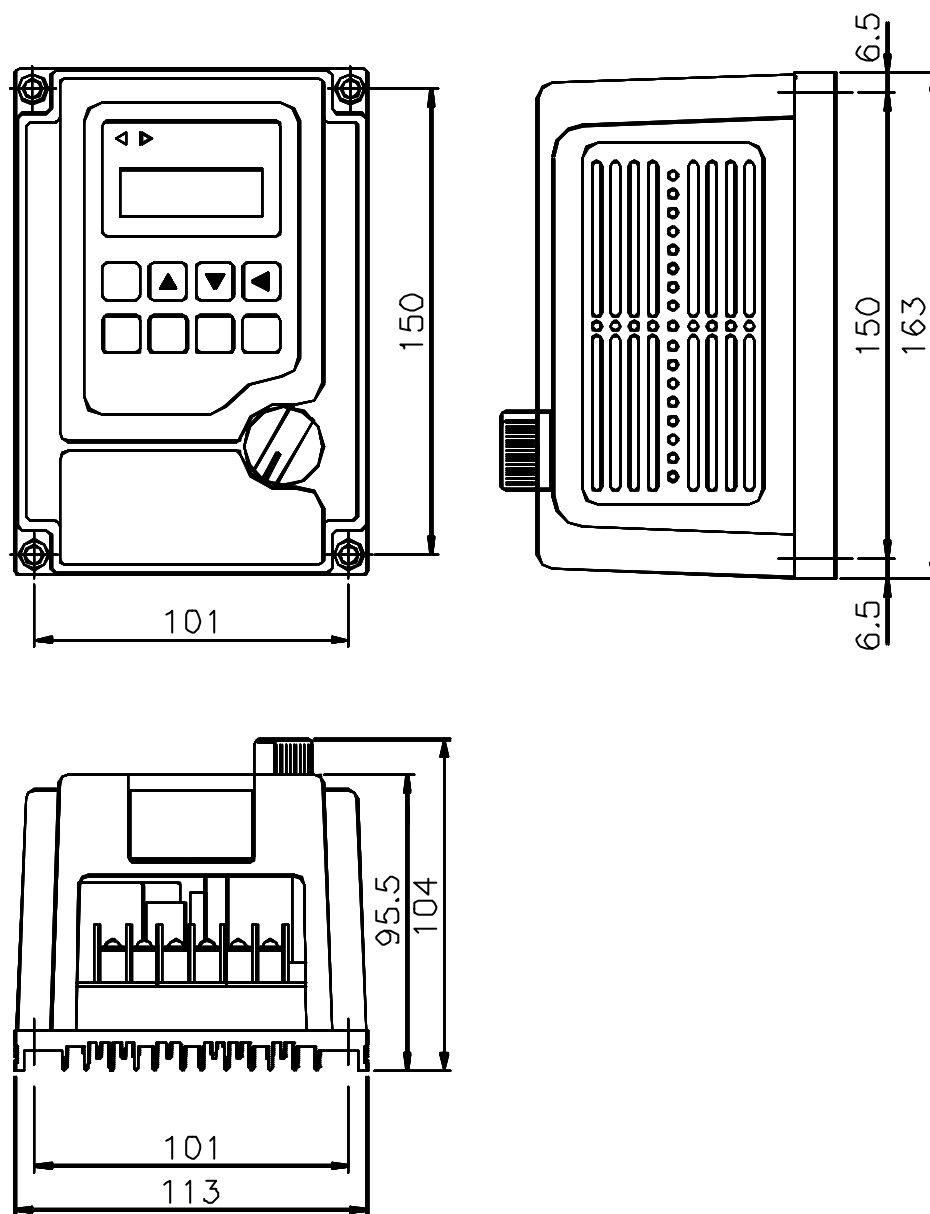
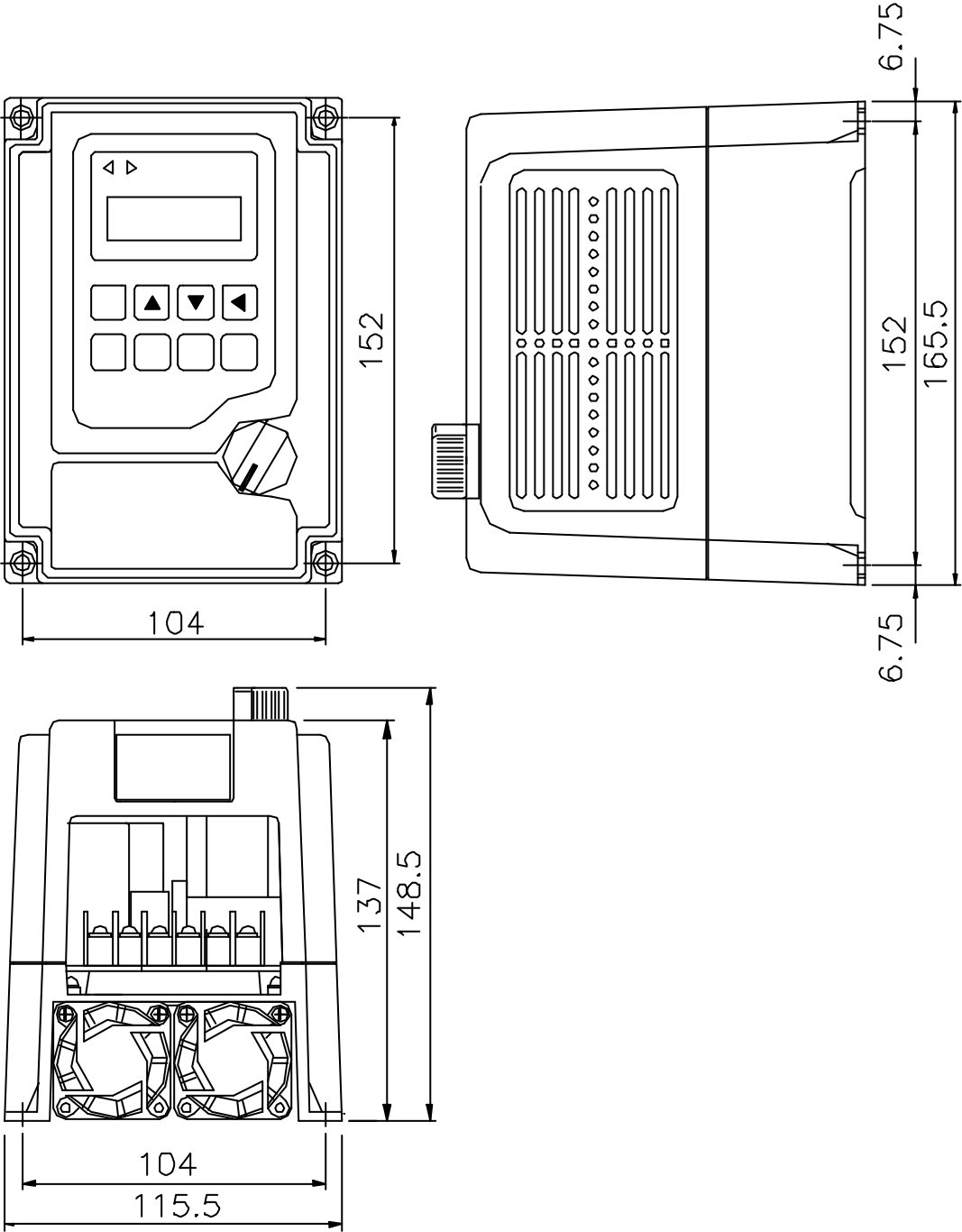

Fig 1

Unit : mm



**Fig 2**

Unit : mm

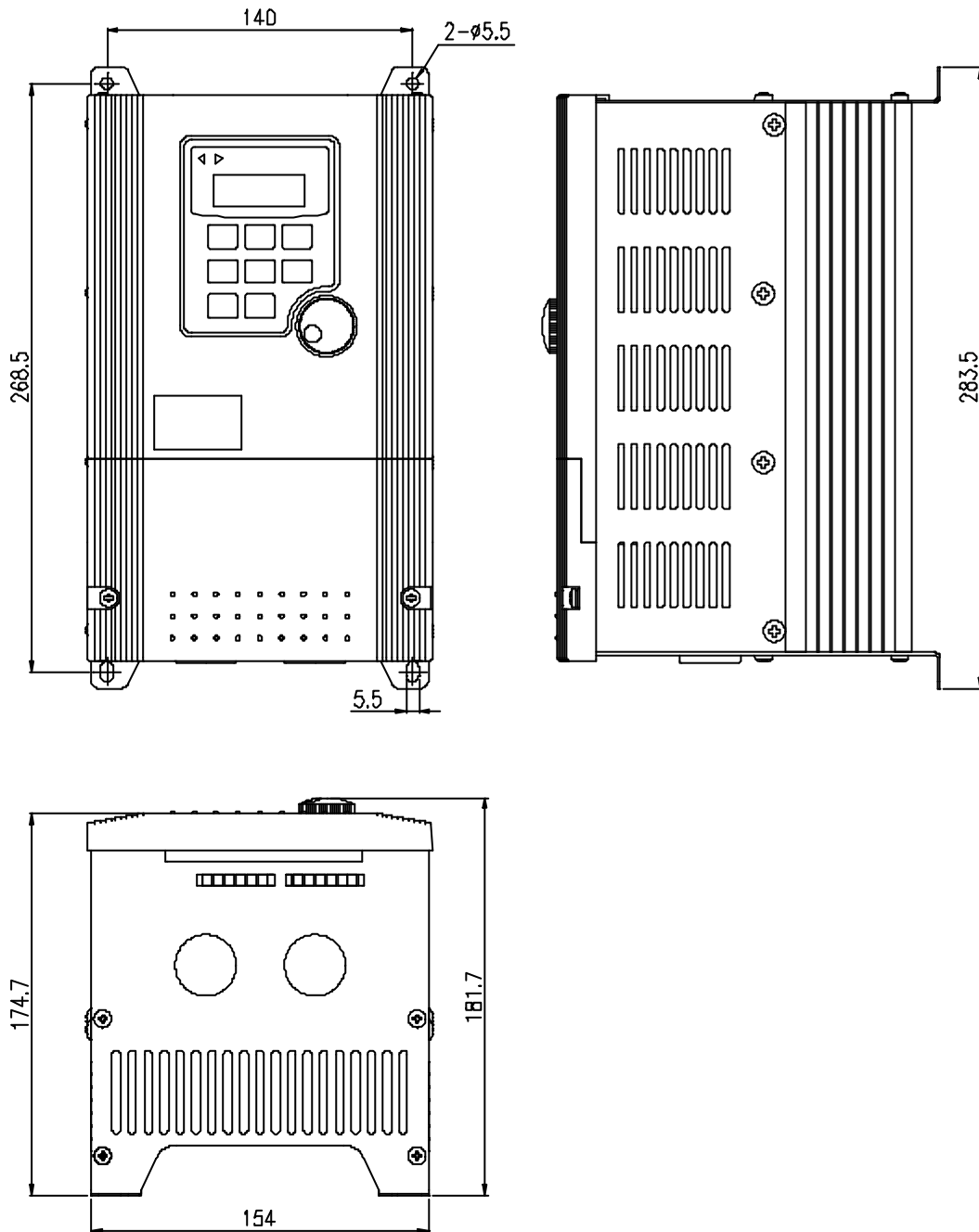

**Fig 3**

## 4. INSTALLATION

Inadequate environment around installation site and installation surface can result in damage to the inverter.

Before operating the AS series inverter, please check the following points :

- (1) Avoid high temperature, high humidity, easy-to-dew ambient environment. Don't expose to dust or dirt, corrosive gas, and coolant mist, and direct sunlight. Place the unit in a well-ventilated room.
- (2) Avoid a place subjected to substantial vibration.
- (3) When installing the unit within the cabinet. Please pay attention to ventilation and limit the ambient temperature in between  $-10 \sim 45$  . ( $14 \sim 113$  ).
- (4) Use a nonflammable material, such a steel sheet on the wall for installation. (The rear side will generate heat)
- (5) Install the unit always vertically with a marginal spacing around.

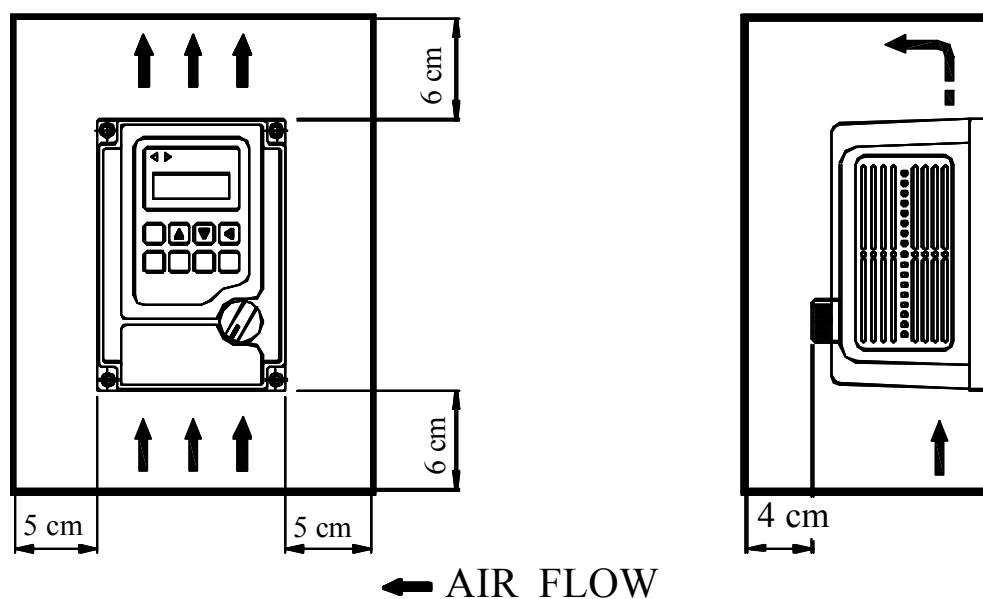

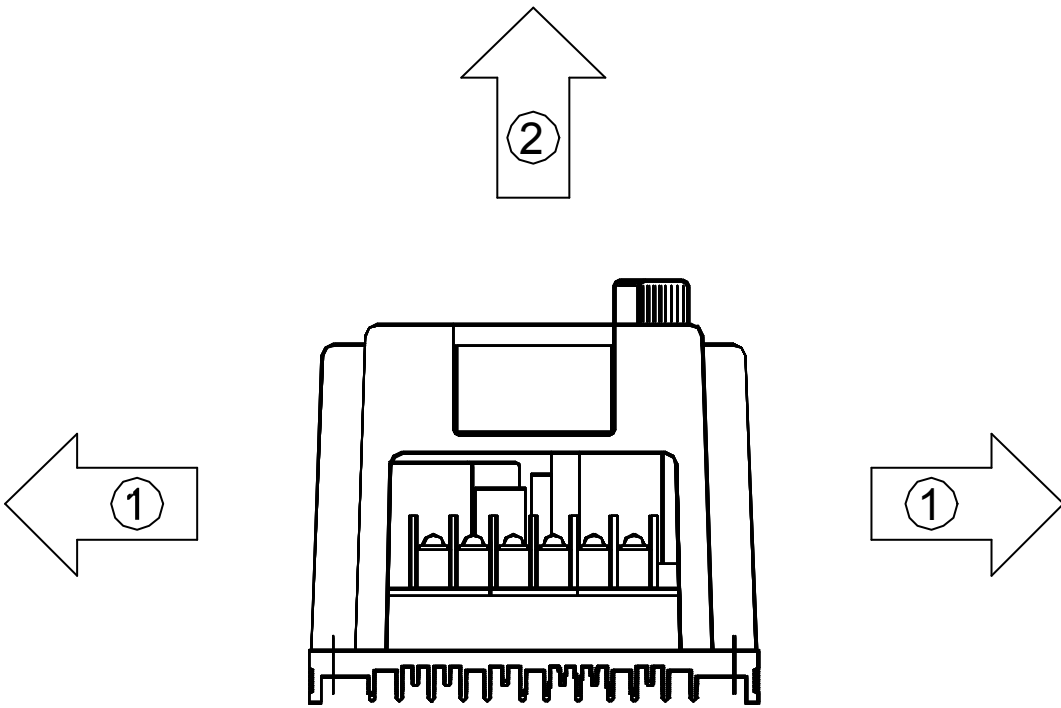
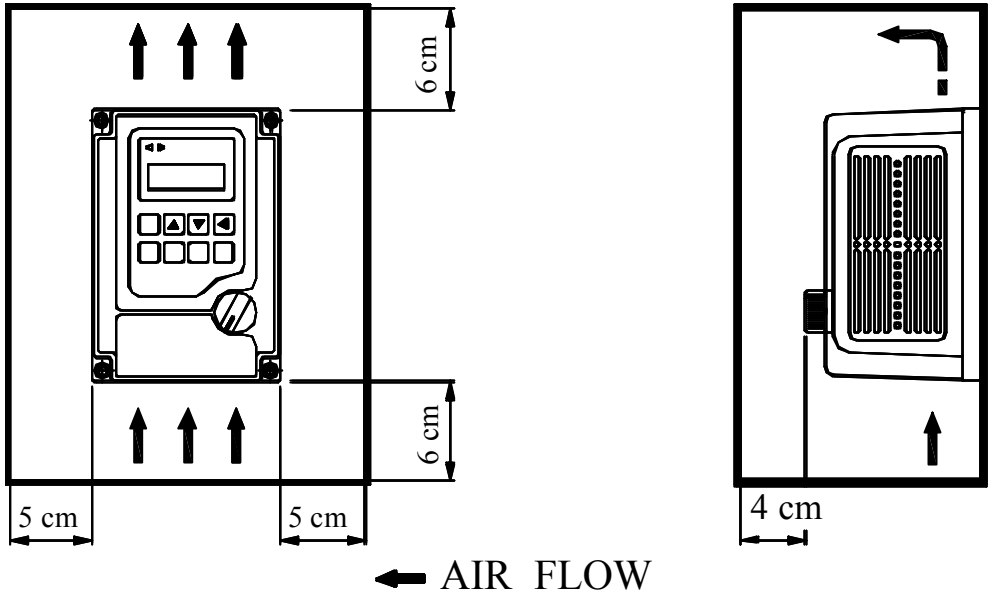

## 5. DESCRIPTION OF TERMINALS

### (1) Main circuit connection diagram

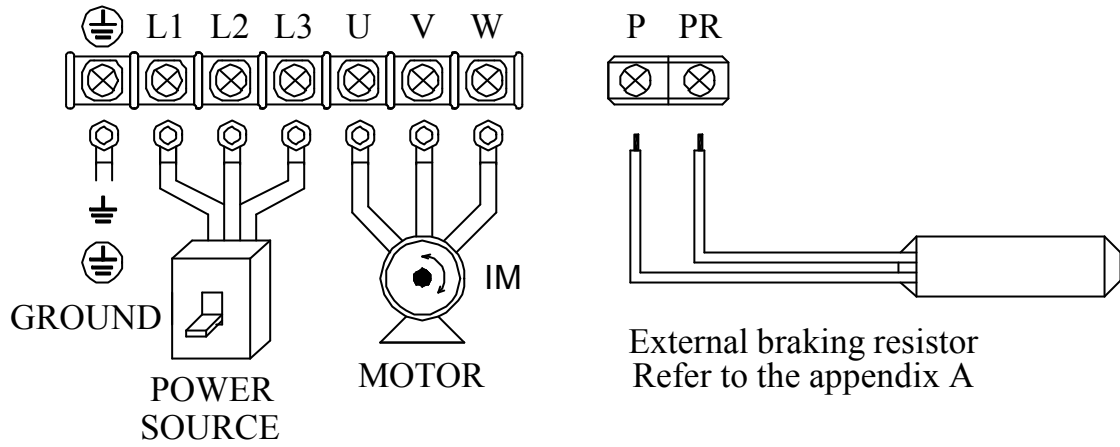

| Main circuit terminal |        |                      |   |
|-----------------------|--------|----------------------|---|
| No.                   | Symbol | Description          | Terminal name   |
| 1                     |        | Ground               | Ground(Earth) Terminal  |
| 2                     | L1     | Connect power supply | (L1,L2) Single Phase<br>(L1,L2,L3) 3 Phase                              |
| 3                     | L2     |                      |   |
| 4                     | L3     |                      |   |
| 5                     | U      | Inverter output      | Terminals connected to motor  |
| 6                     | V      |                      |   |
| 7                     | W      |                      |   |
| 8                     | P      | Dynamic brake        | Terminals connected to braking Resistor, resistance refer to Appendix A |
| 9                     | PR     |                      |   |



(2) Control circuit terminal

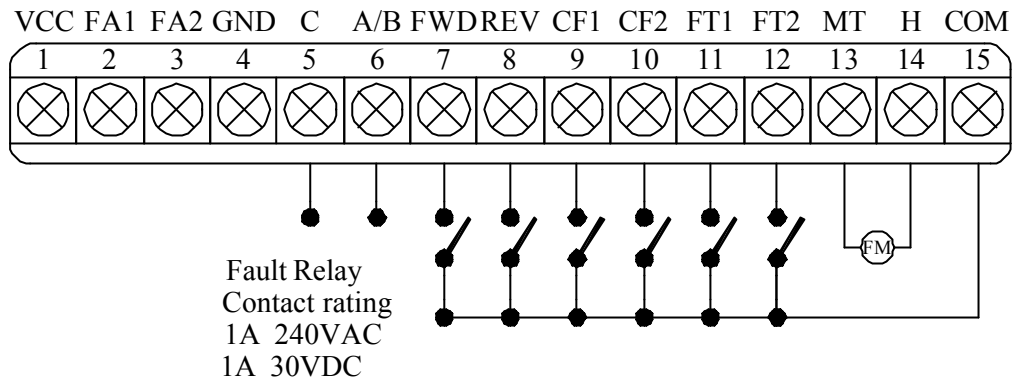

| No | Symbol | Multi function analog terminal |  |
|----|--------|--------------------------------|--|
| 1  | VCC    | Analog source                  | Power source +5V of analog terminals     |
| 2  | FA1    | Free analog terminal 1         | See CD44 & 3-1 SW1                       |
| 3  | FA2    | Free analog terminal 2         | See CD45 & 3-1 SW1                       |
| 4  | GND    | Analog common terminal         | Common terminal of free analog terminals |

| Control circuit terminal |        |  |   |       |     |       |     |     |           |    |     |           |     |    |           |    |    |           |
|--------------------------|--------|--|---|-------|-----|-------|-----|-----|-----------|----|-----|-----------|-----|----|-----------|----|----|-----------|
| No                       | Symbol | Terminal name                                | Description   |       |     |       |     |     |           |    |     |           |     |    |           |    |    |           |
| 5                        | C      | Alarm output C                               | Fault alarm contact (common)  |       |     |       |     |     |           |    |     |           |     |    |           |    |    |           |
| 6                        | A/B    | Alarm output A/B                             | Fault alarm contact A(normal open) / B(normal close)  |       |     |       |     |     |           |    |     |           |     |    |           |    |    |           |
| 7                        | FWD    | Forward operation                            | Forward operation / stop terminal   |       |     |       |     |     |           |    |     |           |     |    |           |    |    |           |
| 8                        | REV    | Reverse operation                            | Reverse operation / stop terminal   |       |     |       |     |     |           |    |     |           |     |    |           |    |    |           |
| 9                        | CF1    | Multistage speed terminal                    | <table border="1"> <thead> <tr> <th>CF1</th> <th>CF2</th> <th>SPEED</th> </tr> </thead> <tbody> <tr> <td>OFF</td> <td>OFF</td> <td>SPEED - 1</td> </tr> <tr> <td>ON</td> <td>OFF</td> <td>SPEED - 2</td> </tr> <tr> <td>OFF</td> <td>ON</td> <td>SPEED - 3</td> </tr> <tr> <td>ON</td> <td>ON</td> <td>SPEED - 4</td> </tr> </tbody> </table> | CF1   | CF2 | SPEED | OFF | OFF | SPEED - 1 | ON | OFF | SPEED - 2 | OFF | ON | SPEED - 3 | ON | ON | SPEED - 4 |
| CF1                      | CF2    |  |   | SPEED |     |       |     |     |           |    |     |           |     |    |           |    |    |           |
| OFF                      | OFF    | SPEED - 1                                    |   |       |     |       |     |     |           |    |     |           |     |    |           |    |    |           |
| ON                       | OFF    | SPEED - 2                                    |   |       |     |       |     |     |           |    |     |           |     |    |           |    |    |           |
| OFF                      | ON     | SPEED - 3                                    |   |       |     |       |     |     |           |    |     |           |     |    |           |    |    |           |
| ON                       | ON     | SPEED - 4                                    |   |       |     |       |     |     |           |    |     |           |     |    |           |    |    |           |
| 10                       | CF2    |  |   |       |     |       |     |     |           |    |     |           |     |    |           |    |    |           |
| 11                       | FT1    | Multi function terminal 1                    | See functions description (CD42)  |       |     |       |     |     |           |    |     |           |     |    |           |    |    |           |
| 12                       | FT2    | Multi function terminal 2                    | See functions description (CD43)  |       |     |       |     |     |           |    |     |           |     |    |           |    |    |           |
| 13                       | MT     | Multi function output terminal (SEE 3-2 JP1) |   |       |     |       |     |     |           |    |     |           |     |    |           |    |    |           |
| 14                       | H      | Ref source +10V                              | Basic source +10V 20mA  |       |     |       |     |     |           |    |     |           |     |    |           |    |    |           |
| 15                       | COM    | Common terminal                              | Common terminal of control terminals  |       |     |       |     |     |           |    |     |           |     |    |           |    |    |           |

### (3) Description of Hardware setting

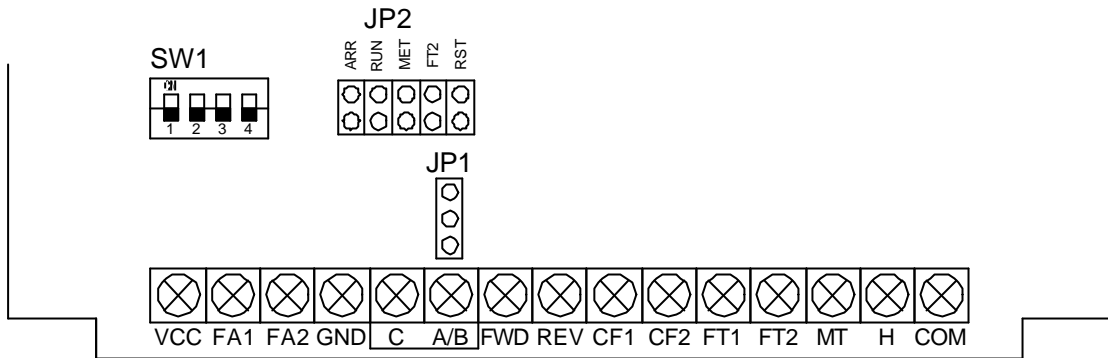

#### 3-1 DIP Switch setting (SW1)

| Setting FA1        | Setting FA2        |
|--------------------|--------------------|
| <br>FA1 : 0 - 10V  | <br>FA2 : 0 - 10V  |
| <br>FA1 : 0 - 5V   | <br>FA2 : 0 - 5V   |
| <br>FA1 : 4 - 20mA | <br>FA2 : 4 - 20mA |
| <br>Error setting  | <br>Error setting  |

#### 3-2 Jumper Setup

1. JP2 : ARR/MET/RUN/RST/FT2 terminal

MT : Multi function output terminal selector signal

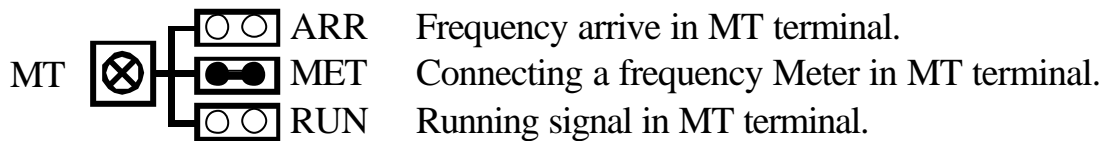

FT2 : Free Terminal 2 function selector



2. JP1 : Fault A(Normal open) / Fault B(Normal close)



## (4) WIRING

### 4-1 Wiring of main circuit

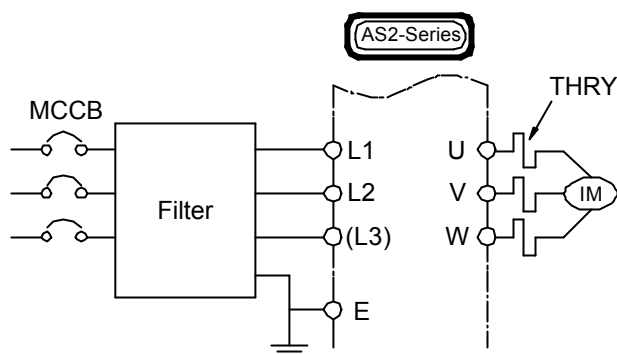

### 4-2 Wiring equipments

Select the wiring equipment and wiring size, refer to the table below.

1. On the input power side, a molded case circuit breaker (MCCB) to protect inverter primary wiring should be installed.
2. A leakage current breaker threshold of 200mA and above, or of inverter use is recommended.
3. Use of input side magnetic contactor. An input MC can be used to prevent an automatic restart after recovery from an external power loss during remote control operation. However, do not use the MC reduced reliability.
4. In general, magnetic contactors on the output of the inverter, Should not be used for motor control. Starting a motor with the inverter running will cause large surge currents and the inverter overcurrent protector to trigger.

| Model                          | AS1 |     | AS2 |     |     |     |     | AS4 |     |     |     |
|--------------------------------|-----|-----|-----|-----|-----|-----|-----|-----|-----|-----|-----|
| Model No                       | 04  | 07  | 04  | 07  | 15  | 22  | 37  | 07  | 15  | 22  | 37  |
| Capacity (KVA)                 | 1.0 | 1.6 | 1.0 | 1.6 | 2.7 | 3.8 | 6.1 | 1.9 | 3.1 | 4.2 | 6.5 |
| Current (A)                    | 2.5 | 4.1 | 2.5 | 4.1 | 7   | 10  | 16  | 2.5 | 4   | 6   | 9   |
| Circuit Breaker (MCCB) (A)     | 15  | 15  | 10  | 10  | 15  | 20  | 20  | 10  | 10  | 10  | 15  |
| Electro-Magnetic Contactor (A) | 12  | 12  | 12  | 12  | 12  | 12  | 18  | 12  | 12  | 12  | 12  |
| Thermal relay RC value (A)     | 4.8 | 7.6 | 2.4 | 3.8 | 6.8 | 9   | 15  | 1.9 | 3.4 | 3.8 | 6.8 |

### 4-3 Surge absorber

In order to prevent malfunction, provide the surge absorber on the coils of the electromagnetic contactors, relays and other devices which are to be used adjacent of the inverter.

### 4-4 Cable size and length

If the inverter is connected to a distant motor (especially when low frequency is output), motor torque decreases because of voltage drop in the cable. Use sufficiently heavy wire.

|  | Wire   | Wire type                          | Torque                  |
|--|--|------------------------------------|-------------------------|
| less than AS2(4)-3HP<br>Input (L1,L2,L3) / $\oplus$ /<br>Output (U,V,W,P,PR) | 14AWG~12AWG<br>(2.0mm <sup>2</sup> ~3.5mm <sup>2</sup> ) | Stranded copper only<br>(600V/80 ) | 10Kg-cm<br>(8.68lb-in)  |
| AS2(4)-5HP<br>Input (L1,L2,L3) / $\oplus$ /<br>Output (U,V,W,P,PR)           | 12AWG<br>(3.5mm <sup>2</sup> )                           | Stranded copper only<br>(600V/80 ) | 12Kg-cm<br>(10.41lb-in) |
| External control signal<br>terminals   | 24AWG~14AWG<br>(0.5mm <sup>2</sup> ~2.0mm <sup>2</sup> ) | Stranded copper only<br>(300V/80 ) | 5.1Kg-cm<br>(4.42lb-in) |

Changing the carrier frequency reduce RF1 noise and leakage current. (Refere to the table below)

| Distance<br>INVERTER MOTOR | under<br>25M   | under<br>50M   | under<br>100M | above<br>100M   |
|----------------------------|----------------|----------------|---------------|-----------------|
| AS2 SERIES                 | under<br>16KHZ | under<br>10KHZ | under<br>5KHZ | under<br>2.5KHZ |

### 4-5 EMI filter specifications

| AS SERIES                   | FREQUENCY (MHZ) |     |    |    |    |    |
|-----------------------------|-----------------|-----|----|----|----|----|
|                             | 0.15            | 0.5 | 1  | 5  | 10 | 30 |
| Typical insertion loss (dB) | 11              | 50  | 62 | 65 | 65 | 60 |

## 4-6 Wiring and cautionary points

### A. Main circuit

1. Connect the cables of the power supply side to the U, V and W output terminals for the motor.
2. Don't connect any electromagnetic contactor between the inverter and motor. If it is inevitable, turn on the contactor when both the inverter and motor are both at stand still.
3. Don't put the advance phase capacitor between the inverter and motor.
4. Put MCCB in the input power supply.

### B. Control signal circuit

1. Separate the power cables of main circuit etc. from the control cables of the sequence and analog signals by passing the cables through the different ducts.
2. Use twisted pair shielded wire for control signal and connect the shield to earth terminal at one end, COMMON terminal of control board. Leave the other end of shielding open.
3. Avoid common Ground leads between high and low level voltage equipment.





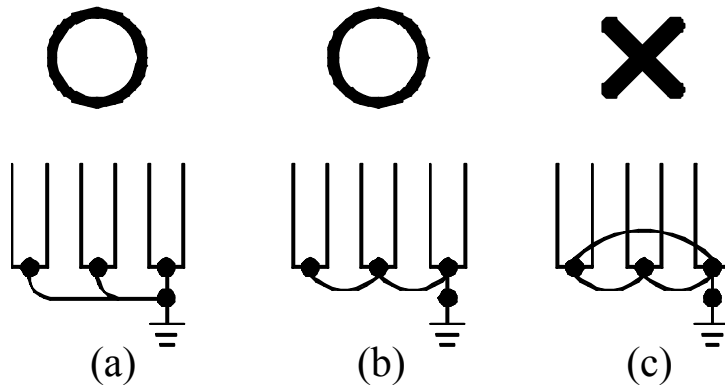

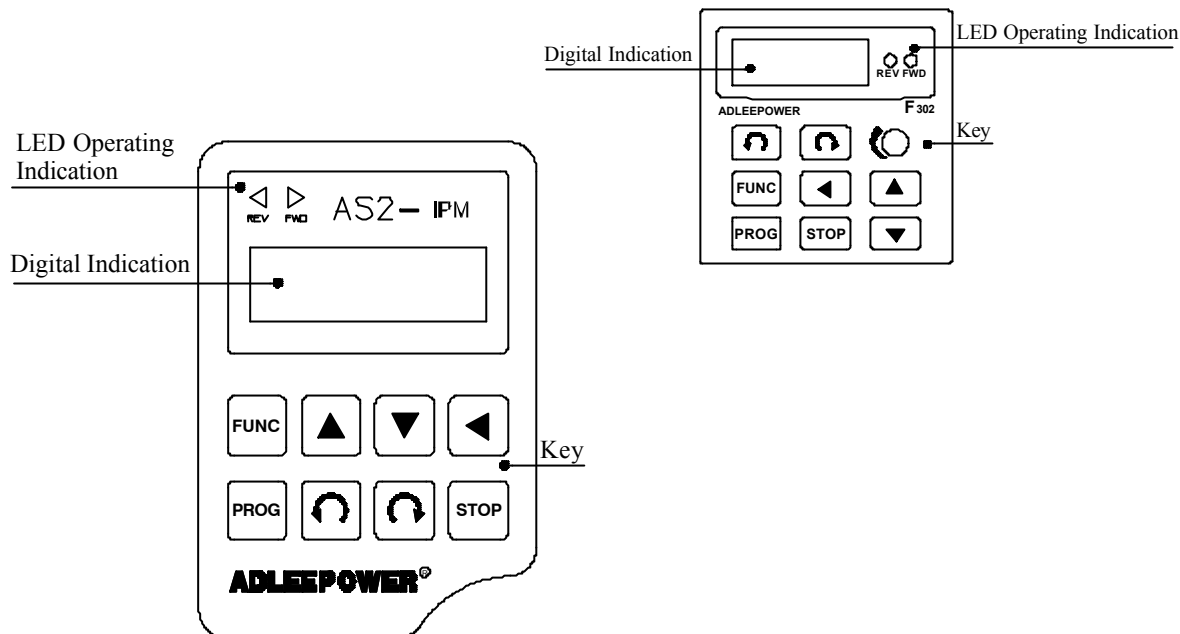

### C. Grounding

1. Be sure ground both the inverter and motor.
2. Keep grounded leads as short as possible.
3. Shield cables used to protect low-level signal leads should be grounded at one end point.
4. Provide class 3 grounding (0.1  $\Omega$  or less) for a terminal.
5. When grounding several inverters, make connections as shown below, no loop is produced as shown in FIG "a", FIG "b".



## 6. DIGITAL OPERATION PANEL



| Operation key   |         | Key function    | Description  |
|---|---------|-----------------|--|
|  | FWD RUN | Forward run     | Commands forward run   |
|  | REV RUN | Reverse run     | Commands reverse run   |
|  | SHIFT   | Cursor movement | Select the digit   |
|  | DOWN    | Down            | Decrease the parameter value   |
|  | UP      | Up              | Increase the parameter value   |
|  | PROG    | Memory storage  | Saves the setting vaule  |
|  | FUNC    | Function        | Press once to select function CDxx and press again to change its content |
|  | STOP    | Stop            | Stop operation / Escape to standby mode                                  |

## 7. FUNCTIONS DESCRIPTION

| DISPLAY ORDER | FUNCTION NAME                          | STANDARD SETTING VALUE |
|---------------|--|------------------------|
| CD00          | First speed setting                    | U : 60HZ               |
|               |  | E : 50(B03) / 0(B04)   |
| CD01          | Parameter lock                         | 0                      |
| CD02          | Acceleration time 1                    | 10 Sec                 |
| CD03          | Deceleration time 1                    | 10 Sec                 |
| CD04          | Jogging frequency                      | 5HZ                    |
| CD05          | Start frequency                        | 0.5HZ                  |
| CD06          | Jog mode                               | 0                      |
| CD07          | Frequency meter correspond             | U : 120 HZ             |
|               |  | E : 100 HZ             |
| CD08          | CW or CCW or CW / CCW                  | 0                      |
| CD09          | Reserved                               | 0                      |
| CD10          | Keyboard / Analog signal from terminal | 0                      |
| CD11          | Dynamic brake / Free running           | 0                      |
| CD12          | Terminal / Key board command           | 0                      |
| CD13          | Reserved                               |                        |
| CD14          | Maximum frequency limit                | U : 120 HZ             |
|               |  | E : 50 HZ              |
| CD15          | Minimum frequency limit                | 0                      |
| CD16          | Frequency display Scale                | U : 1                  |
|               |  | E : 30                 |
| CD17          | Maximum voltage frequency              | U : 60 HZ              |
|               |  | E : 50 HZ              |

Different initial set value for E : European version and U : US version.  
To change version see description of CD52.

| <b>CHANGEABLE OF SETTING VALUE</b> | <b>UNIT</b>    | <b>USER SETTING</b> | <b>REMARK</b>                                |
|------------------------------------|----------------|---------------------|--|
| <b>0 ~ 400 HZ</b>                  | <b>0.01 HZ</b> |                     |  |
| <b>0 or 1</b>                      | <b>—</b>       |                     | <b>0 = lock 1 = Unlock</b>                   |
| <b>0.1 ~ 6000 Sec</b>              | <b>0.1 Sec</b> |                     |  |
| <b>0.1 ~ 6000 Sec</b>              | <b>0.1 Sec</b> |                     |  |
| <b>0 ~ 400 HZ</b>                  | <b>0.01 HZ</b> |                     |  |
| <b>0.5 ~ 30 HZ</b>                 | <b>0.01 HZ</b> |                     |  |
| <b>0 or 1</b>                      | <b>—</b>       |                     | <b>0 = Normal 1 = Jog</b>                    |
| <b>30 ~ 400 HZ</b>                 | <b>0.01 HZ</b> |                     |  |
| <b>0 ~ 2</b>                       | <b>—</b>       |                     | <b>0 = CW/CCW 1 = CW 2 = CCW</b>             |
|                                    |                |                     |  |
| <b>0 or 1</b>                      | <b>—</b>       |                     | <b>0 = Keyboard input 1 = Frequency knob</b> |
| <b>0 or 1</b>                      | <b>—</b>       |                     | <b>0 = Dynamic brake 1 = Free running</b>    |
| <b>0 or 1</b>                      | <b>—</b>       |                     | <b>0 = Keyboard 1 = Terminal</b>             |
|                                    |                |                     |  |
| <b>0.5 ~ 400 HZ</b>                | <b>0.01 HZ</b> |                     |  |
| <b>0 ~ 400 HZ</b>                  | <b>0.01 HZ</b> |                     |  |
| <b>0.01 ~ 500</b>                  | <b>0.01</b>    |                     | <b>Display = Frequency × Scale</b>           |
| <b>25 ~ 400 HZ</b>                 | <b>0.01 HZ</b> |                     |  |



| <b>DISPLAY ORDER</b> | <b>FUNCTION NAME</b>                      | <b>STANDARD SETTING VALUE</b> |
|----------------------|---|-------------------------------|
| <b>CD18</b>          | <b>V/F pattern setting</b>                | <b>0</b>                      |
| <b>CD19</b>          | <b>DC braking time</b>                    | <b>1 Sec</b>                  |
| <b>CD20</b>          | <b>DC braking power</b>                   | <b>10</b>                     |
| <b>CD21</b>          | <b>Torque boost</b>                       | <b>0 %</b>                    |
| <b>CD22</b>          | <b>Second speed setting</b>               | <b>20 (B03) / 0 (B04)</b>     |
| <b>CD23</b>          | <b>Third speed setting</b>                | <b>30 (B03) / 0 (B04)</b>     |
| <b>CD24</b>          | <b>Fourth speed setting</b>               | <b>40 (B03) / 0 (B04)</b>     |
| <b>CD25</b>          | <b>Acceleration time 2</b>                | <b>10 Sec</b>                 |
| <b>CD26</b>          | <b>Deceleration time 2</b>                | <b>10 Sec</b>                 |
| <b>CD27</b>          | <b>Carrier frequency</b>                  | <b>15.0 KHZ</b>               |
| <b>CD28</b>          | <b>Output voltage gain</b>                | <b>100 %</b>                  |
| <b>CD29</b>          | <b>Frequency jump 1</b>                   | <b>0 HZ</b>                   |
| <b>CD30</b>          | <b>Frequency jump 2</b>                   | <b>0 HZ</b>                   |
| <b>CD31</b>          | <b>Frequency jump 3</b>                   | <b>0 HZ</b>                   |
| <b>CD32</b>          | <b>Jump range</b>                         | <b>0.5 HZ</b>                 |
| <b>CD33</b>          | <b>Frequency reference bias</b>           | <b>0</b>                      |
| <b>CD34</b>          | <b>Frequency reference bias direction</b> | <b>0</b>                      |
| <b>CD35</b>          | <b>Frequency gain</b>                     | <b>100.0 %</b>                |
| <b>CD36</b>          | <b>The latest error record</b>            | <b>NONE</b>                   |
| <b>CD37</b>          | <b>Errors record 1</b>                    | <b>NONE</b>                   |

| <b>CHANGEABLE<br/>OF SETTING<br/>VALUE</b> | <b>UNIT</b>    | <b>USER<br/>SETTING</b> | <b>REMARK</b>  |
|--|----------------|-------------------------|--|
| <b>0 ~ 2</b>                               | <b>---</b>     |                         | <b>0 : Constant torque<br/>1 : (Frequency) 2.0<br/>2 : (Frequency) 3.0</b> |
| <b>0 ~ 25 Sec</b>                          | <b>0.1 Sec</b> |                         |  |
| <b>0 ~ 250</b>                             | <b>1.00</b>    |                         |  |
| <b>0 ~ 25%</b>                             | <b>0.1 %</b>   |                         |  |
| <b>0 ~ 400 HZ</b>                          | <b>0.01 HZ</b> |                         |  |
| <b>0 ~ 400 HZ</b>                          | <b>0.01 HZ</b> |                         |  |
| <b>0 ~ 400 HZ</b>                          | <b>0.01 HZ</b> |                         |  |
| <b>0.1 ~ 6000 Sec</b>                      | <b>0.1 Sec</b> |                         |  |
| <b>0.1 ~ 6000 Sec</b>                      | <b>0.1 Sec</b> |                         |  |
| <b>1.0 ~ 15.0 KHZ</b>                      | <b>0.1 KHZ</b> |                         |  |
| <b>50 ~ 100 %</b>                          | <b>0.1 %</b>   |                         |  |
| <b>0 ~ 400 HZ</b>                          | <b>0.01 HZ</b> |                         |  |
| <b>0 ~ 400 HZ</b>                          | <b>0.01 HZ</b> |                         |  |
| <b>0 ~ 400 HZ</b>                          | <b>0.01 HZ</b> |                         |  |
| <b>0.5 ~ 3 HZ</b>                          | <b>0.01 HZ</b> |                         |  |
| <b>0 ~ 400 HZ</b>                          | <b>0.01 HZ</b> |                         |  |
| <b>0 or 1</b>                              | <b>---</b>     |                         | <b>0 = Positive 1 = Negative</b>   |
| <b>40 ~ 200 %</b>                          | <b>0.1 %</b>   |                         |  |
|  |                |                         |  |
|  |                |                         |  |

| <b>DISPLAY ORDER</b> | <b>FUNCTION NAME</b>                 | <b>STANDARD SETTING VALUE</b> |
|----------------------|--------------------------------------|-------------------------------|
| <b>CD38</b>          | <b>Errors record 2</b>               | <b>NONE</b>                   |
| <b>CD39</b>          | <b>Errors record 3</b>               | <b>NONE</b>                   |
| <b>CD40</b>          | <b>Clear errors record</b>           | <b>0</b>                      |
| <b>CD41</b>          | <b>HZ / RPM Display</b>              | <b>0</b>                      |
| <b>CD42</b>          | <b>FT1 Multi-Function Terminal 1</b> | <b>0</b>                      |
| <b>CD43</b>          | <b>FT2 Multi-Function Terminal 2</b> | <b>0</b>                      |
| <b>CD44</b>          | <b>FA1 Free Analog Terminal 1</b>    | <b>0</b>                      |
| <b>CD45</b>          | <b>FA2 Free Analog Terminal 2</b>    | <b>0</b>                      |
| <b>CD46</b>          | <b>Run frequency setting</b>         | <b>0.5 HZ</b>                 |
| <b>CD47</b>          | <b>5th speed setting</b>             | <b>25 (B03) / 0 (B04)</b>     |
| <b>CD48</b>          | <b>6th speed setting</b>             | <b>35 (B03) / 0 (B04)</b>     |
| <b>CD49</b>          | <b>7th speed setting</b>             | <b>45 (B03) / 0 (B04)</b>     |
| <b>CD50</b>          | <b>8th speed setting</b>             | <b>55 (B03) / 0 (B04)</b>     |
| <b>CD51</b>          | <b>Dynamic Braking Energy Limit</b>  | <b>100</b>                    |
| <b>CD52</b>          | <b>Version selector</b>              |                               |
| <b>CD53</b>          | <b>S curve</b>                       | <b>0</b>                      |
| <b>CD54</b>          | <b>4 ~ 20mA speed command</b>        | <b>0</b>                      |
| <b>CD55</b>          | <b>Frequency arrive signal range</b> | <b>10 %</b>                   |
| <b>CD56</b>          | <b>2nd Maximum voltage frequency</b> | <b>60 HZ</b>                  |
| <b>CD57</b>          | <b>Timer FWD/REV setting</b>         | <b>0</b>                      |
| <b>CD58</b>          | <b>Auto running mode</b>             | <b>0</b>                      |
| <b>CD59</b>          | <b>1st step timer</b>                | <b>0.01</b>                   |

| CHANGEABLE OF SETTING VALUE | UNIT             | USER SETTING | REMARK                         |
|-----------------------------|------------------|--------------|--------------------------------|
|                             |                  |              |                                |
|                             |                  |              |                                |
| 0 or 1                      | ----             |              | 1 = Clear                      |
| 0 or 1                      | ----             |              | 0 = HZ Display 1 = RPM Display |
| 0 or 1                      | ----             |              |                                |
| 0 ~ 15                      | ----             |              |                                |
| 0 ~ 15                      | ----             |              |                                |
| 0 ~ 15                      | ----             |              |                                |
| 0.5 ~ 400.0 HZ              | 0.01 HZ          |              |                                |
| 0 ~ 400 HZ                  | 0.01 HZ          |              |                                |
| 0 ~ 400 HZ                  | 0.01 HZ          |              |                                |
| 0 ~ 400 HZ                  | 0.01 HZ          |              |                                |
| 0 ~ 400 HZ                  | 0.01 HZ          |              |                                |
| 0 ~ 300                     | 1                |              | 0 = Auto turning               |
| EUR                         | European Version |              |                                |
| USA                         | US Version       |              |                                |
| 0 ~ 10                      |                  |              | 0 = Normal 1~10 = S Surve      |
| 0 ~ 3                       |                  |              |                                |
| 0 ~ 100 %                   | 1 %              |              |                                |
| 25 ~ 400 HZ                 | 0.01 HZ          |              |                                |
| 0 ~ 31                      |                  |              |                                |
| 0 ~ 4                       |                  |              |                                |
| 0 ~ 15Hr                    | hr.min           |              |                                |



| <b>DISPLAY ORDER</b>  | <b>FUNCTION NAME</b>       | <b>STANDARD SETTING VALUE</b> |
|-----------------------|----------------------------|-------------------------------|
| <b>CD60</b>           | <b>2st step timer</b>      | <b>0.00</b>                   |
| <b>CD61</b>           | <b>3st step timer</b>      | <b>0.00</b>                   |
| <b>CD62</b>           | <b>4st step timer</b>      | <b>0.00</b>                   |
| <b>CD63</b>           | <b>5st step timer</b>      | <b>0.00</b>                   |
| <b>CD64</b>           | <b>Timer unit selector</b> | <b>0</b>                      |
| <b>CD65~<br/>CD90</b> | <b>Reserved</b>            |                               |
| <b>CD91</b>           | <b>RUN terminal</b>        | <b>0</b>                      |
| <b>CD92</b>           | <b>ARR terminal</b>        | <b>1</b>                      |

This function provides different standard setting values for European and USA Version.

| CHANGEABLE OF SETTING VALUE | UNIT   | USER SETTING | REMARK |
|-----------------------------|--------|--------------|--------|
| 0 ~ 15Hr                    | hr.min |              |        |
| 0 ~ 15Hr                    | hr.min |              |        |
| 0 ~ 15Hr                    | hr.min |              |        |
| 0 ~ 15Hr                    | hr.min |              |        |
| 0 or 1                      |        |              |        |
|                             |        |              |        |
| 0 ~ 3                       |        |              |        |
| 0 ~ 3                       |        |              |        |





## 7-1. Function setting

Before starting test run, check carefully the following points :



- (1) Be sure to connect the power supply to L1, L2, L3 (input terminals) and the motor to U.V.W. (output terminals). (Wrong connections will damage the inverter.)
- (2) Check that the input power supply coincide with input voltage and input phase of the inverter.
- (3) Check the signal lines for correct wiring.
- (4) Be sure to ground an earth terminal for personnel safety.
- (5) Check that other terminals other than earth terminal are not grounded.
- (6) Check that the inverter is mounted on the wall. Also check that non-flammable material.
- (7) For operation start and stop, use    and FWD / REV terminals. Never use input power supply to switch ON/OFF.

### Operating

Action : (a) Press   for forward / reverse operation.

function : (a) Press    for function setting and confirm by  .



speed : (a) Using frequency knob for motor speed setting.

(b) Using keyboard   and  for motor speed setting. set CD10 = 0 at first, see Function description

Standby : (a) Press  back to standby mode after trip or function setting mode.

|                            |
|----------------------------|
| <b>First speed setting</b> |
| <b>CD00</b>                |

|                         |                           |
|-------------------------|---------------------------|
| <b>Setting Range</b>    | <b>0 ~ 400 HZ</b>         |
| <b>USA Version</b>      | <b>60 HZ</b>              |
| <b>European Version</b> | <b>50 (B03) / 0 (B04)</b> |

Press   key for increase or decrease the speed with 1HZ increment step for quick setting.

Press  key to select the digit.

Press  to save the setting value.

|                       |
|-----------------------|
| <b>Parameter lock</b> |
| <b>CD01</b>           |

|                        |               |
|------------------------|---------------|
| <b>Setting Range</b>   | <b>0 or 1</b> |
| <b>Factory Setting</b> | <b>0</b>      |

0 : Lock 1 : Unlock

Function to prevent inadequate setting.

To change the contents CD02 ~ CD56 , set CD01=1 and press  first.

To lock the data set CD01=0 and press  .

|                            |
|----------------------------|
| <b>Acceleration time 1</b> |
| <b>CD02</b>                |

|                        |                       |
|------------------------|-----------------------|
| <b>Setting Range</b>   | <b>0.1 ~ 6000 Sec</b> |
| <b>Factory Setting</b> | <b>10 Sec</b>         |

CD02 value corresponds to the time of acceleration from the minimum frequency to 60HZ.(For 120Hz. setting, the arrival time to 120Hz is double.)

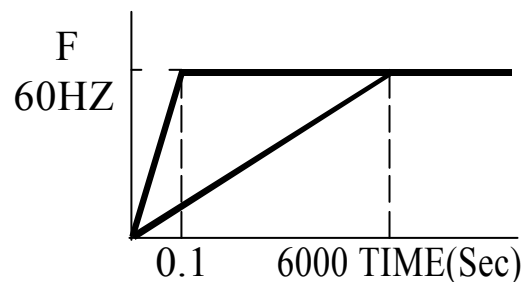



|                            |
|----------------------------|
| <b>Deceleration time 1</b> |
| <b>CD03</b>                |

|                        |                       |
|------------------------|-----------------------|
| <b>Setting Range</b>   | <b>0.1 ~ 6000 Sec</b> |
| <b>Factory Setting</b> | <b>10 Sec</b>         |

CD03 value corresponds to the time of deceleration from 60HZ to the minimum frequency.

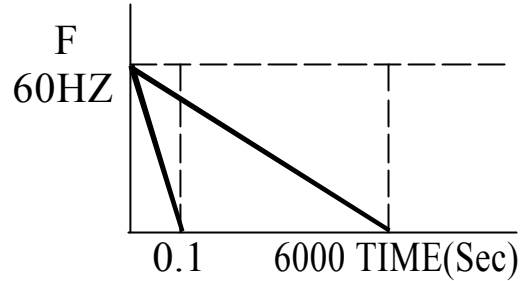

|                          |
|--------------------------|
| <b>Jogging frequency</b> |
| <b>CD04</b>              |

|                        |                   |
|------------------------|-------------------|
| <b>Setting Range</b>   | <b>0 ~ 400 HZ</b> |
| <b>Factory Setting</b> | <b>5 HZ</b>       |

Use terminal control refer to CD12 and CD42 setting, keyboard control refer to CD06.

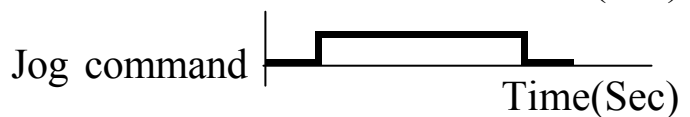
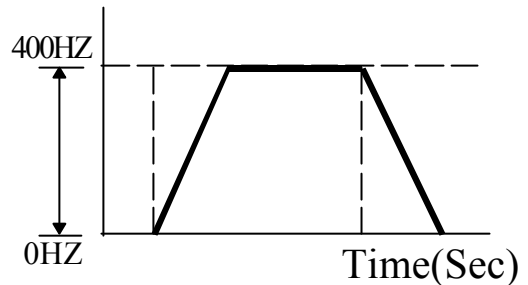

|                        |
|------------------------|
| <b>Start frequency</b> |
| <b>CD05</b>            |

|                        |                    |
|------------------------|--------------------|
| <b>Setting Range</b>   | <b>0.5 ~ 30 HZ</b> |
| <b>Factory Setting</b> | <b>0.5 HZ</b>      |



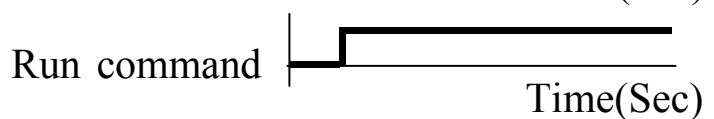
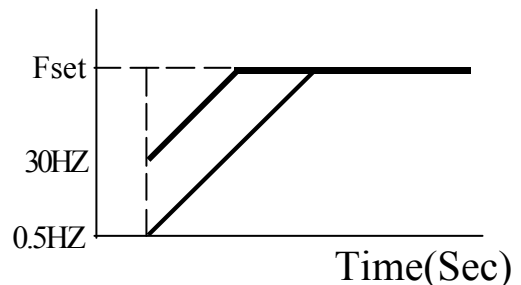

When setting this value, pay attention to the starting current.



|                 |
|-----------------|
| <b>Jog mode</b> |
| <b>CD06</b>     |

|                        |               |
|------------------------|---------------|
| <b>Setting Range</b>   | <b>0 or 1</b> |
| <b>Factory Setting</b> | <b>0</b>      |

0 : Normal      1 : Jog Mode

1. Set jogging operation from key panel  &  .
2.   LED blinking in JOG mode.

|                                   |
|-----------------------------------|
| <b>Frequency meter correspond</b> |
| <b>CD07</b>                       |

|                         |                          |
|-------------------------|--------------------------|
| <b>Setting Range</b>    | <b>30.00 ~ 400.00 HZ</b> |
| <b>USA Version</b>      | <b>120.00 HZ</b>         |
| <b>European Version</b> | <b>100.00 HZ</b>         |

The specification of the output meter is 10V(i.e. 1mA) full scale rating and 30~400HZ frequency range.

Set by CD07 the value will be correspond to maximum correspond of output meter.

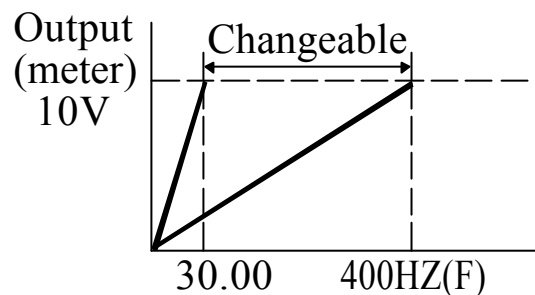

|                            |
|----------------------------|
| <b>CW or CCW or CW/CCW</b> |
| <b>CD08</b>                |



|                        |              |
|------------------------|--------------|
| <b>Setting Range</b>   | <b>0 ~ 2</b> |
| <b>Factory Setting</b> | <b>0</b>     |

- 0 : CW/CCW operation  
 1 : CW only  
 2 : CCW only



If inadequate operation, the “OPE2“ warning message would be indicated.

|                                   |
|-----------------------------------|
| <b>Analog / Digital frequency</b> |
| <b>CD10</b>                       |

|                        |               |
|------------------------|---------------|
| <b>Setting Range</b>   | <b>0 or 1</b> |
| <b>Factory Setting</b> | <b>1</b>      |

0 : Operation frequency change by using  or  key and confirm by  .

1 : Operation frequency change by adjusting the angle of the knob.

Note : Using   key to change motor speed when CD01=1, the “OPE3“ warning message would be indicated.

|                                     |
|-------------------------------------|
| <b>Dynamic brake / Free running</b> |
| <b>CD11</b>                         |

|                        |               |
|------------------------|---------------|
| <b>Setting Range</b>   | <b>0 or 1</b> |
| <b>Factory Setting</b> | <b>0</b>      |

0 : Activates dynamic brake function when deceleration. Decelerating time depends on CD3 setting.

1 : Output cut off when accept a stop command.

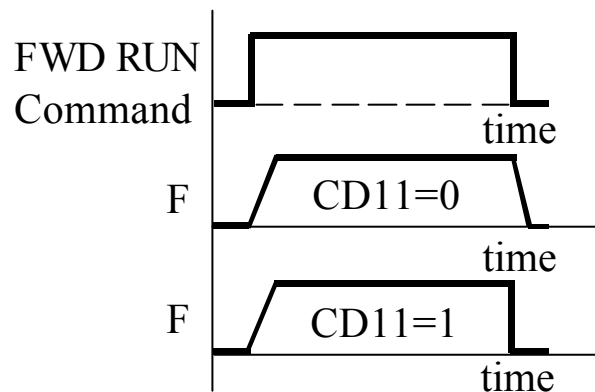

|                                     |
|-------------------------------------|
| <b>Terminal / Key board command</b> |
| <b>CD12</b>                         |

|                         |               |
|-------------------------|---------------|
| <b>Setting Range</b>    | <b>0 or 1</b> |
| <b>USA Version</b>      | <b>0</b>      |
| <b>European Version</b> | <b>1</b>      |

0 : RUN/STOP Command from operation panel.

1 : RUN/STOP Command from control terminal.

Note : If inadequate operation, the “OPE4“ warning message would be indicated.

|                                |
|--------------------------------|
| <b>Maximum frequency limit</b> |
| <b>CD14</b>                    |

|                         |                     |
|-------------------------|---------------------|
| <b>Setting Range</b>    | <b>0.5 ~ 400 HZ</b> |
| <b>USA Version</b>      | <b>120 HZ</b>       |
| <b>European Version</b> | <b>50 HZ</b>        |

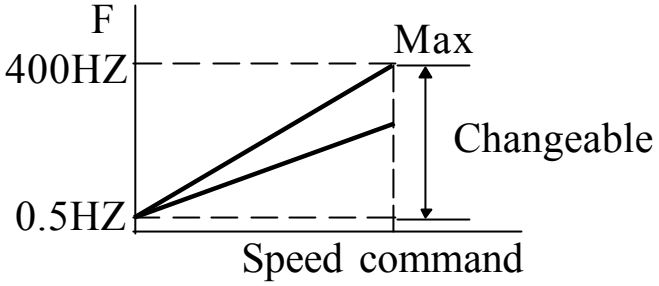

|                                |
|--------------------------------|
| <b>Minimum frequency limit</b> |
| <b>CD15</b>                    |

|                        |                   |
|------------------------|-------------------|
| <b>Setting Range</b>   | <b>0 ~ 400 HZ</b> |
| <b>Factory Setting</b> | <b>0</b>          |

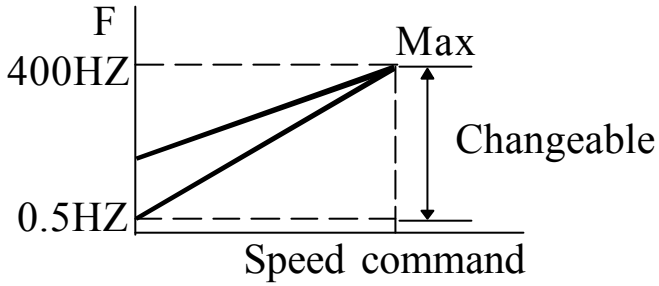

|                                |
|--------------------------------|
| <b>Frequency display scale</b> |
| <b>CD16</b>                    |

|                         |                      |
|-------------------------|----------------------|
| <b>Setting Range</b>    | <b>0.01 ~ 500 HZ</b> |
| <b>USA Version</b>      | <b>1 HZ</b>          |
| <b>European Version</b> | <b>30 HZ</b>         |

Use the following equation to calculate the mechanical shaft speed in rpm.

$$\text{RPM} = \text{HZ} \times \text{Scale setting}$$

When  $\text{RPM} > 9999$  display 

|   |   |   |   |
|---|---|---|---|
| - | - | E | - |
|---|---|---|---|

 for over range warning.

Setting CD41=1 for display shown RPM.

| Pole | Synchronous speed |      | Scale setting |
|------|-------------------|------|---------------|
|      | 50HZ              | 60HZ |               |
| 2    | 3000              | 3600 | 60            |
| 4    | 1500              | 1800 | 30            |
| 6    | 1000              | 1200 | 20            |
| 8    | 750               | 900  | 15            |
| 10   | 600               | 720  | 12            |
| 12   | 500               | 600  | 10            |

|                                  |
|----------------------------------|
| <b>Maximum voltage frequency</b> |
| <b>CD17</b>                      |

|                         |                    |
|-------------------------|--------------------|
| <b>Setting Range</b>    | <b>25 ~ 400 HZ</b> |
| <b>USA Version</b>      | <b>60 HZ</b>       |
| <b>European Version</b> | <b>50 HZ</b>       |

For constant torque and constant power setting.

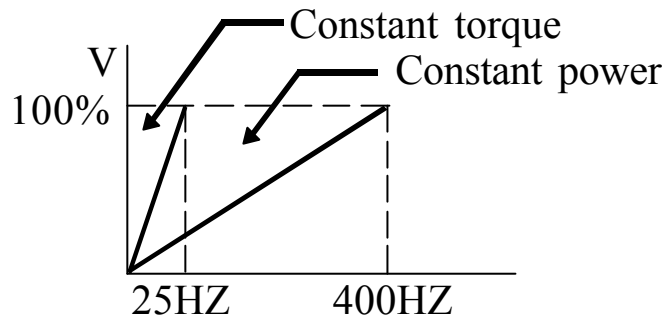

|                    |
|--------------------|
| <b>V/F pattern</b> |
| <b>CD18</b>        |

|                        |              |
|------------------------|--------------|
| <b>Setting Range</b>   | <b>0 ~ 2</b> |
| <b>Factory Setting</b> | <b>0</b>     |

- 0 = Constant torque curve
- 1 = Reduce torque curve  $F^{2.0}$
- 2 = Reduce torque curve  $F^{3.0}$

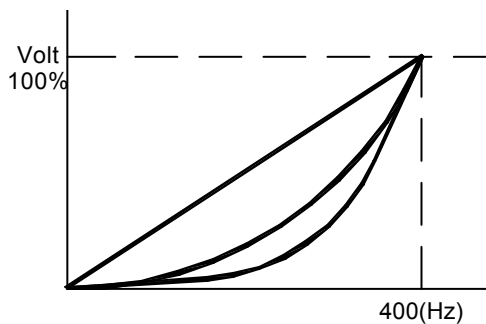

|                        |
|------------------------|
| <b>DC braking time</b> |
| <b>CD19</b>            |

|                        |                   |
|------------------------|-------------------|
| <b>Setting Range</b>   | <b>0 ~ 25 Sec</b> |
| <b>Factory Setting</b> | <b>1 Sec</b>      |

DC brake starting at frequency under 0.5HZ.

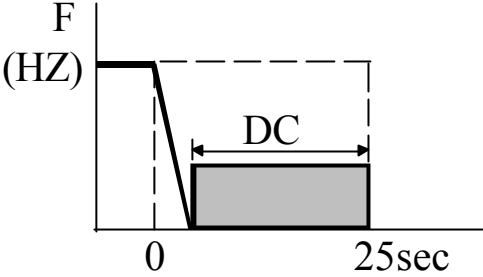

|                         |
|-------------------------|
| <b>DC braking power</b> |
| <b>CD20</b>             |

|                        |                |
|------------------------|----------------|
| <b>Setting Range</b>   | <b>0 ~ 250</b> |
| <b>Factory Setting</b> | <b>10</b>      |

CD20 setting DC voltage gain various braking power.

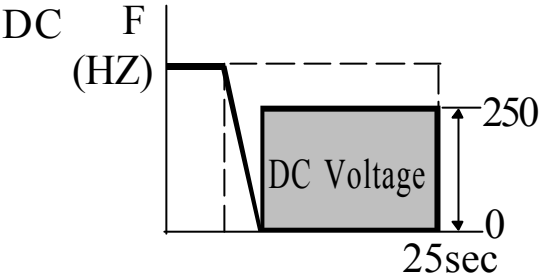

|                     |
|---------------------|
| <b>Torque boost</b> |
| <b>CD21</b>         |

|                        |                 |
|------------------------|-----------------|
| <b>Setting Range</b>   | <b>0 ~ 25 %</b> |
| <b>Factory Setting</b> | <b>0 %</b>      |

Torque boosting is used to compensate the torque lost due to stator resistance. Over boosting will cause over current and high acoustic noise.

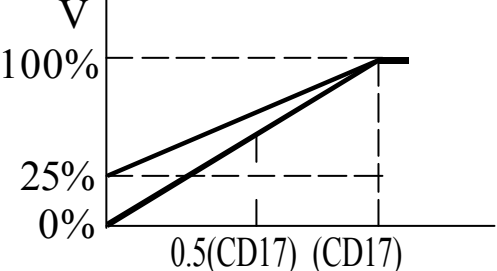

|                             |
|-----------------------------|
| <b>Second speed setting</b> |
| <b>CD22</b>                 |

|                        |                           |
|------------------------|---------------------------|
| <b>Setting Range</b>   | <b>0 ~ 400 HZ</b>         |
| <b>Factory Setting</b> | <b>20 (B03) / 0 (B04)</b> |

|                            |
|----------------------------|
| <b>Third speed setting</b> |
| <b>CD23</b>                |

|                        |                           |
|------------------------|---------------------------|
| <b>Setting Range</b>   | <b>0 ~ 400 HZ</b>         |
| <b>Factory Setting</b> | <b>30 (B03) / 0 (B04)</b> |

|                             |
|-----------------------------|
| <b>Fourth speed setting</b> |
| <b>CD24</b>                 |

|                        |                           |
|------------------------|---------------------------|
| <b>Setting Range</b>   | <b>0 ~ 400 HZ</b>         |
| <b>Factory Setting</b> | <b>40 (B03) / 0 (B04)</b> |

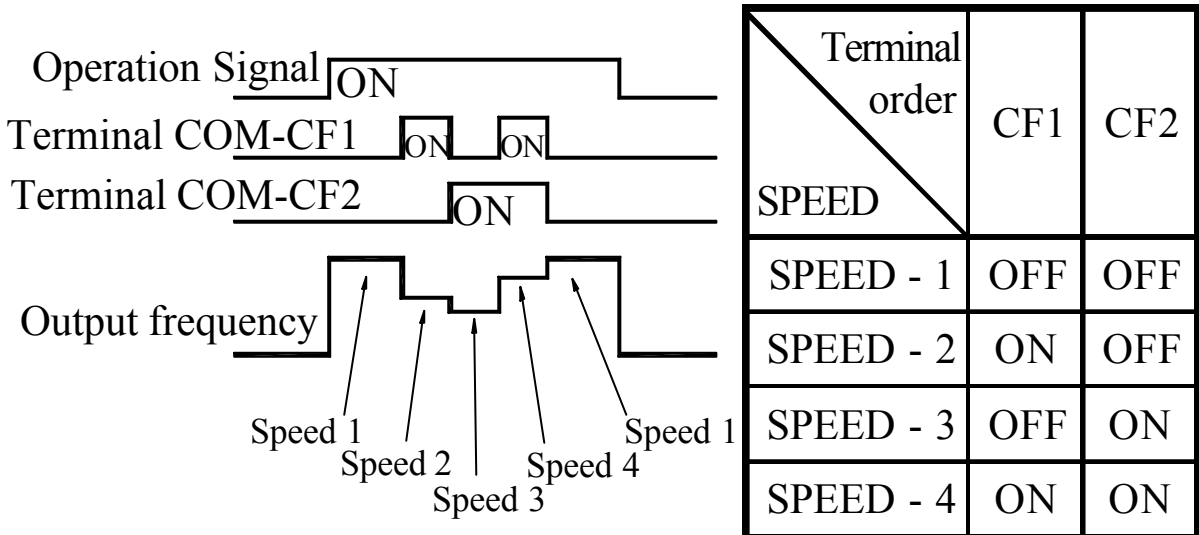

|                            |
|----------------------------|
| <b>Acceleration time 2</b> |
| <b>CD25</b>                |

|                        |                       |
|------------------------|-----------------------|
| <b>Setting Range</b>   | <b>0.1 ~ 6000 SEC</b> |
| <b>Factory Setting</b> | <b>10 SEC</b>         |

|                            |
|----------------------------|
| <b>Deceleration time 2</b> |
| <b>CD26</b>                |

|                        |                       |
|------------------------|-----------------------|
| <b>Setting Range</b>   | <b>0.1 ~ 6000 SEC</b> |
| <b>Factory Setting</b> | <b>10 SEC</b>         |

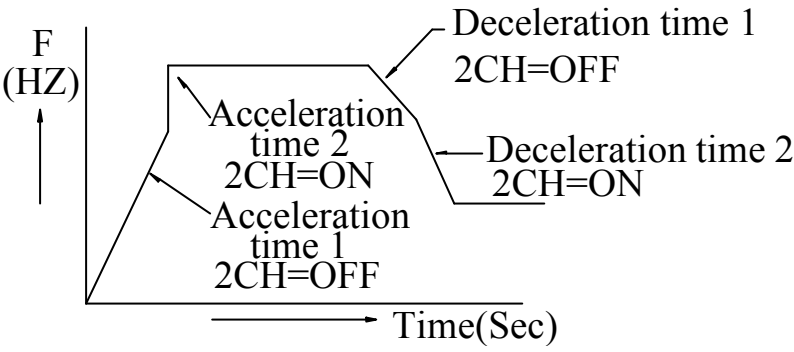

|                     |     |
|---------------------|-----|
| Description         | 2CH |
| Acceleration time 1 | OFF |
| Deceleration time 1 |     |
| Acceleration time 2 | ON  |
| Deceleration time 2 |     |

To operate inverter with 2CH function, check to see CD42 or CD43=3. 2CH command inputs from FT1 or FT2 terminal.

|                          |
|--------------------------|
| <b>Carrier frequency</b> |
| <b>CD27</b>              |

|                        |                     |
|------------------------|---------------------|
| <b>Setting Range</b>   | <b>1.0 ~ 15.0 K</b> |
| <b>Factory Setting</b> | <b>15.0 K</b>       |

Increase the carrier frequency would reduce motor acoustic noise but efficiency might be decreased.

Reduce the carrier frequency would reduce RF1 noise, reduce motor current, and then gain better efficiency.

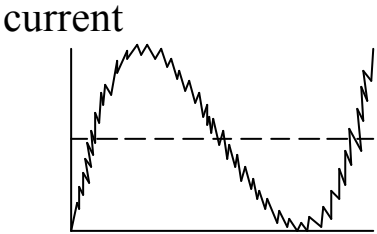

Low carrier frequency

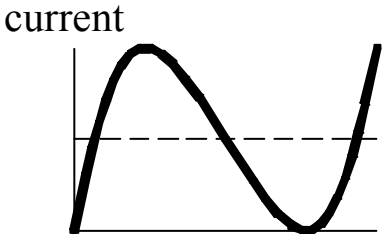

High carrier frequency



|                            |
|----------------------------|
| <b>Output voltage gain</b> |
| <b>CD28</b>                |

|                        |                   |
|------------------------|-------------------|
| <b>Setting Range</b>   | <b>50 ~ 100 %</b> |
| <b>Factory Setting</b> | <b>100 %</b>      |

Reduce output voltage for energy saving operation.  
 Setting CD44(45)=12 for FA1 (FA2) terminal control.

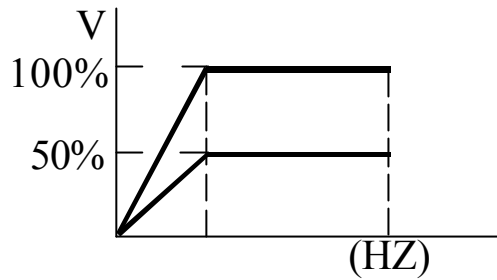

|                         |
|-------------------------|
| <b>Frequency jump 1</b> |
| <b>CD29</b>             |

|                        |                   |
|------------------------|-------------------|
| <b>Setting Range</b>   | <b>0 ~ 400 HZ</b> |
| <b>Factory Setting</b> | <b>0 HZ</b>       |

|                         |
|-------------------------|
| <b>Frequency jump 2</b> |
| <b>CD30</b>             |

|                        |                   |
|------------------------|-------------------|
| <b>Setting Range</b>   | <b>0 ~ 400 HZ</b> |
| <b>Factory Setting</b> | <b>0 HZ</b>       |

|                         |
|-------------------------|
| <b>Frequency jump 3</b> |
| <b>CD31</b>             |

|                        |                   |
|------------------------|-------------------|
| <b>Setting Range</b>   | <b>0 ~ 400 HZ</b> |
| <b>Factory Setting</b> | <b>0 HZ</b>       |

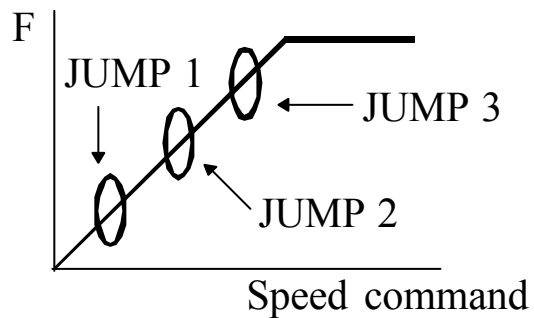

|                   |
|-------------------|
| <b>Jump range</b> |
| <b>CD32</b>       |

|                        |                   |
|------------------------|-------------------|
| <b>Setting Range</b>   | <b>0.5 ~ 3 HZ</b> |
| <b>Factory Setting</b> | <b>0.5 HZ</b>     |

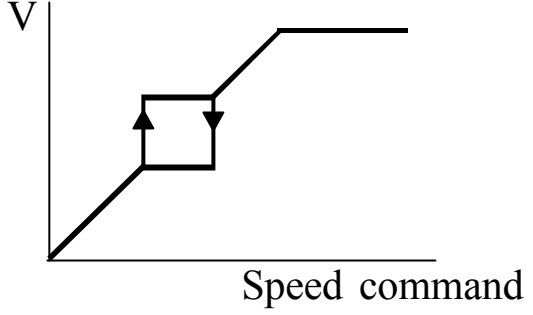

|                                 |
|---------------------------------|
| <b>Frequency reference bias</b> |
| <b>CD33</b>                     |

|                        |                   |
|------------------------|-------------------|
| <b>Setting Range</b>   | <b>0 ~ 400 HZ</b> |
| <b>Factory Setting</b> | <b>0</b>          |

Move Frequency bias with same gradient.  
 Frequency at negative bias range, The motor can not start.

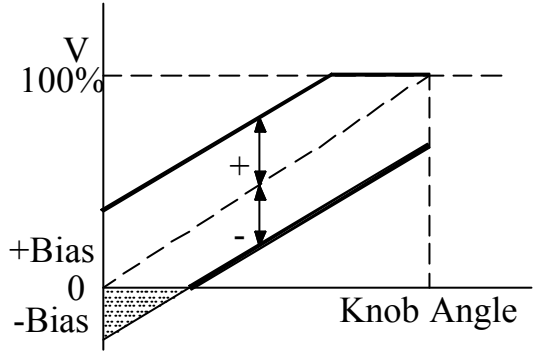

|                                  |
|----------------------------------|
| <b>Freq. ref. bias direction</b> |
| <b>CD34</b>                      |

|                        |               |
|------------------------|---------------|
| <b>Setting Range</b>   | <b>0 or 1</b> |
| <b>Factory Setting</b> | <b>0</b>      |

0 = Positive “+”  
 1 = Negative “-”  
 Polarity setting for (CD33) frequency reference bias.

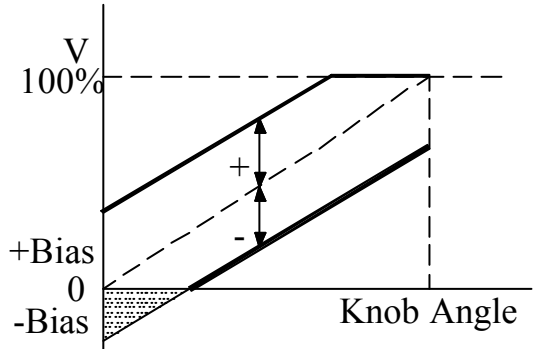

|                       |
|-----------------------|
| <b>Frequency gain</b> |
| <b>CD35</b>           |

|                        |                   |
|------------------------|-------------------|
| <b>Setting Range</b>   | <b>40 ~ 200 %</b> |
| <b>Factory Setting</b> | <b>100 %</b>      |

Application refer to example 04.

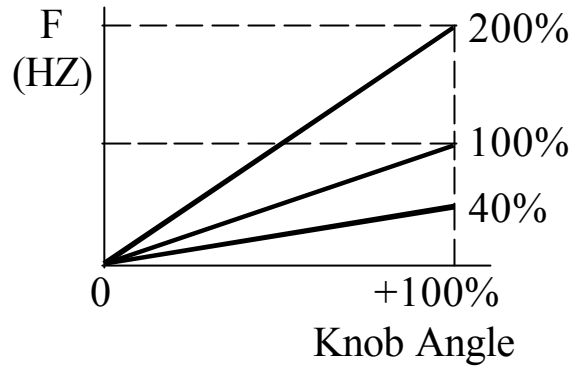

|                                |
|--------------------------------|
| <b>The latest error record</b> |
| <b>CD36</b>                    |

|                       |
|-----------------------|
| <b>Error record 1</b> |
| <b>CD37</b>           |

|                       |
|-----------------------|
| <b>Error record 2</b> |
| <b>CD38</b>           |

|                       |
|-----------------------|
| <b>Error record 3</b> |
| <b>CD39</b>           |

Errors record flow-chart when Error occur. The new content will shift the other contents to one higher CD code and the highest one will be dropped.



|                            |
|----------------------------|
| <b>Clear errors record</b> |
| <b>CD40</b>                |

|                        |               |
|------------------------|---------------|
| <b>Setting Range</b>   | <b>0 or 1</b> |
| <b>Factory Setting</b> | <b>0</b>      |

Set CD40=1 and **PROG** clear CD36 ~ CD39 Error Record the contents in CD36 ~ CD39 are “ NONE “

|                       |
|-----------------------|
| <b>HZ/RPM Display</b> |
| <b>CD41</b>           |

|                        |               |
|------------------------|---------------|
| <b>Setting Range</b>   | <b>0 or 1</b> |
| <b>Factory Setting</b> | <b>0</b>      |

0 = HZ Display    1 = RPM Display  
 Setting current scale CD16 for rpm display shown.

|                                      |
|--------------------------------------|
| <b>FT1 Multi-Function Terminal 1</b> |
| <b>CD42</b>                          |

|                        |               |
|------------------------|---------------|
| <b>Setting Range</b>   | <b>0 ~ 15</b> |
| <b>Factory Setting</b> | <b>0</b>      |

| FT1<br>FT2 | Symbol   | Function description              |
|------------|----------|-----------------------------------|
| 0          | -----    | -----                             |
| 1          | JOGF     | Jog operation FWD command         |
| 2          | JOGR     | Jog operation REV command         |
| 3          | 2CH      | ACC/DEC time 2 command            |
| 4          | FRS      | Free running command              |
| 5          | 3 - WIRE | 3 - wire sequence mode            |
| 6          | CF3      | 5 - 8 Speed Setting Terminal      |
| 7          | VF2      | 2nd V/F curve setting (CD56)      |
| 8          |          | Reserved                          |
| 9          | OH       | External over temperature command |
| 10         | Timer    | Timer RUN trigger                 |
| 11~15      |          | Reserved                          |

### 3 - WIRE CIRCUIT CONNECTION DIAGRAM (terminal latch function)

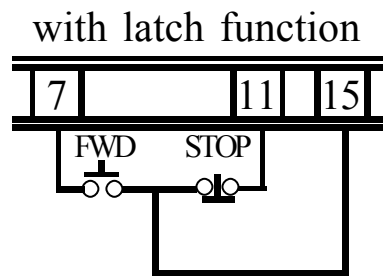
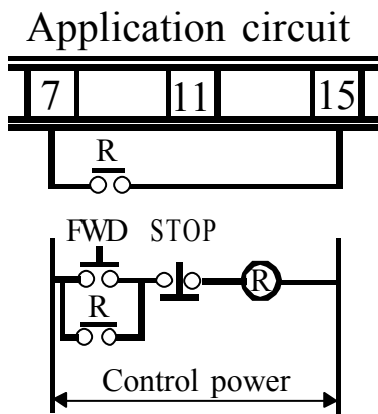
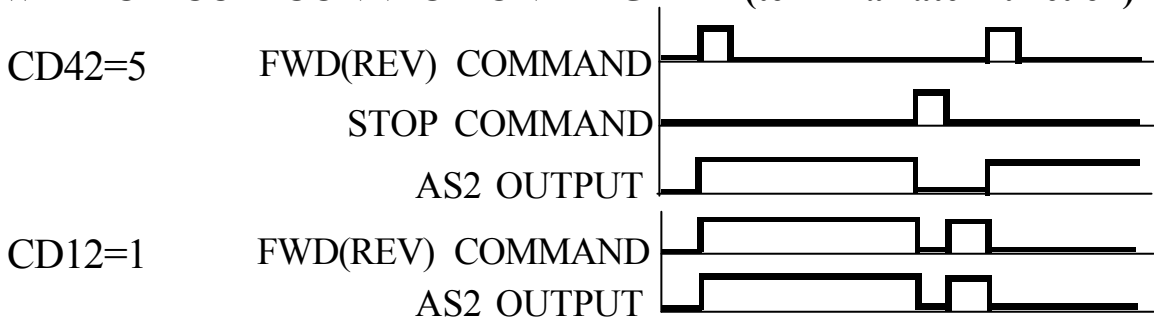

Ⓜ and CONTROL POWER not necessary  
 Remark: STOP command entry from control terminal ⑪ FT1 or ⑫ FT2, and set CD42(FT1)=5 or CD43(FT2)=5 before operation.

|  |
|--|
| <b>FT2 Multi-Function<br/>Terminal 2</b> |
| <b>CD43</b>                              |

|                        |               |
|------------------------|---------------|
| <b>Setting Range</b>   | <b>0 ~ 15</b> |
| <b>Factory Setting</b> | <b>0</b>      |

Refer to CD42 table.

Used for connection refer to 3-2 jumper setup (page 11).

|                                   |
|-----------------------------------|
| <b>Free analog<br/>terminal 1</b> |
| <b>CD44</b>                       |

|                        |               |
|------------------------|---------------|
| <b>Setting Range</b>   | <b>0 ~ 15</b> |
| <b>Factory Setting</b> | <b>0</b>      |

Refer to CD45 table.

|                                   |
|-----------------------------------|
| <b>Free analog<br/>terminal 2</b> |
| <b>CD45</b>                       |

|                        |               |
|------------------------|---------------|
| <b>Setting Range</b>   | <b>0 ~ 15</b> |
| <b>Factory Setting</b> | <b>0</b>      |

Setting NO. 11 to use application of example 04.

| <b>FA1<br/>FA2</b> | <b>Function</b>            | <b>Setting Range<br/>Min-----Max</b> |
|--------------------|----------------------------|--------------------------------------|
| <b>0</b>           | -----                      | -----                                |
| <b>1</b>           | <b>Acceleration time 1</b> | <b>0 ~ CD02 Content</b>              |
| <b>2</b>           | <b>Deceleration time 1</b> | <b>0 ~ CD03 Content</b>              |
| <b>3</b>           | <b>Acceleration time 2</b> | <b>0 ~ CD25 Content</b>              |
| <b>4</b>           | <b>Deceleration time 2</b> | <b>0 ~ CD26 Content</b>              |
| <b>5</b>           | <b>Boost setting</b>       | <b>0.0 ~ 25.0 %</b>                  |
| <b>6</b>           | <b>DC Brake time</b>       | <b>0 ~ 25 Sec</b>                    |
| <b>7</b>           | <b>DC Brake Energy</b>     | <b>0 ~ 250</b>                       |
| <b>8</b>           | <b>Speed 2</b>             | <b>F-min ~ F-max</b>                 |
| <b>9</b>           | <b>Speed 3</b>             | <b>F-min ~ F-max</b>                 |
| <b>10</b>          | <b>Speed 4</b>             | <b>F-min ~ F-max</b>                 |
| <b>11</b>          | <b>Fmax</b>                | <b>F-min ~ CD14 content</b>          |
| <b>12</b>          | <b>Output voltage gain</b> | <b>50% ~ 100%</b>                    |
| <b>13</b>          | <b>Speed 1</b>             | <b>F-min ~ F-max</b>                 |
| <b>14</b>          | <b>Reserved</b>            |                                      |
| <b>15</b>          | <b>Reserved</b>            |                                      |

|                              |
|------------------------------|
| <b>Run frequency setting</b> |
| <b>CD46</b>                  |

|                        |                       |
|------------------------|-----------------------|
| <b>Setting Range</b>   | <b>0.5 ~ 400.0 HZ</b> |
| <b>Factory Setting</b> | <b>0.5 HZ</b>         |

Run terminal output signal if frequency reaches setting value.

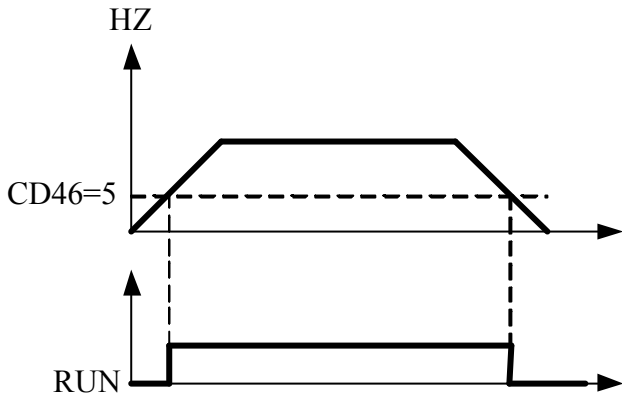

|                          |
|--------------------------|
| <b>5th speed setting</b> |
| <b>CD47</b>              |

|                          |
|--------------------------|
| <b>6th speed setting</b> |
| <b>CD48</b>              |

|                          |
|--------------------------|
| <b>7th speed setting</b> |
| <b>CD49</b>              |

| SPEED             | CF3 | CF2 | CF1 |
|-------------------|-----|-----|-----|
| 1th speed setting | OFF | OFF | OFF |
| 2th speed setting | OFF | OFF | ON  |
| 3th speed setting | OFF | ON  | OFF |
| 4th speed setting | OFF | ON  | ON  |
| 5th speed setting | ON  | OFF | OFF |
| 6th speed setting | ON  | OFF | ON  |
| 7th speed setting | ON  | ON  | OFF |
| 8th speed setting | ON  | ON  | ON  |

|                          |
|--------------------------|
| <b>8th speed setting</b> |
| <b>CD50</b>              |

For example, set 8th speed as follows :

1. CD12=1 (Terminal function)
2. CD42 or CD43=6 (Function command)  
(FT1 or FT2 → CF3)

|                                     |
|-------------------------------------|
| <b>Dynamic braking energy limit</b> |
| <b>CD51</b>                         |

The higher the percentage, the more braking energy.

The lower the percentage, the lower braking energy.

Description of regenerative discharge braking active period.

1. 0 ~ 100% Decel only
2. 101 ~ 200% Braking active period of  
(Decel/accel/constant frequency)
3. 201 ~ 300% Braking active period of  
(Decel/accel/constant frequency/stand-by)

|                         |
|-------------------------|
| <b>Version selector</b> |
| <b>CD52</b>             |

|                                      |
|--------------------------------------|
| <b>Eur</b> → <b>European Version</b> |
| <b>USA</b> → <b>US Version</b>       |

Select function CD52, then use UP/Down key to select Eur/USA

Version. Press  to save it. System return to the factory setting.



|                |
|----------------|
| <b>S curve</b> |
| <b>CD53</b>    |

|                        |               |
|------------------------|---------------|
| <b>Setting Range</b>   | <b>0 ~ 10</b> |
| <b>Factory Setting</b> | <b>0</b>      |

Setting S curve non-Linear Accel/Decel Operation from 1 to 10.  
 Setting 0 is normal operation without S curve.

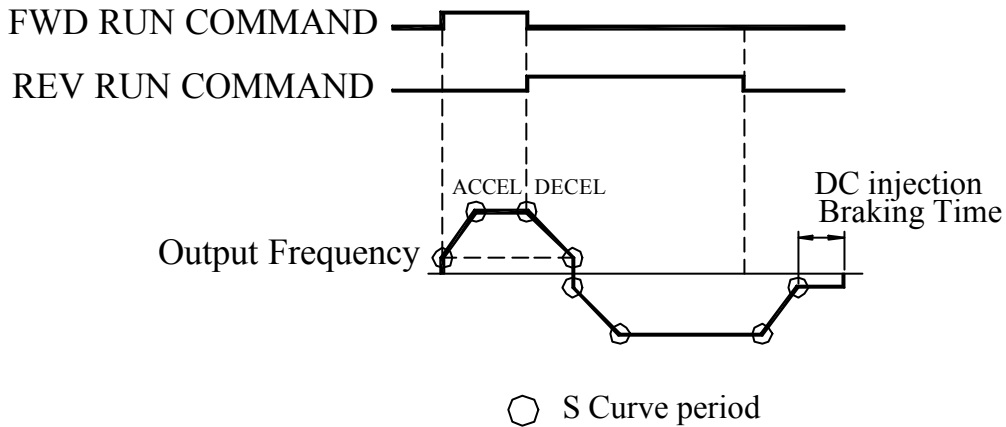
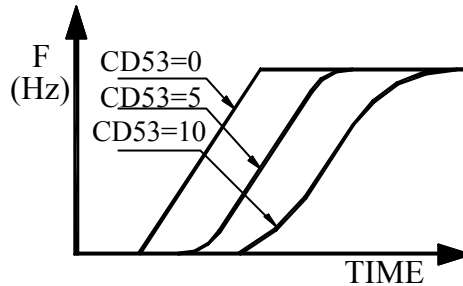

|                  |
|------------------|
| <b>4 ~ 20 mA</b> |
| <b>CD54</b>      |

|                        |              |
|------------------------|--------------|
| <b>Setting Range</b>   | <b>0 ~ 3</b> |
| <b>Factory Setting</b> | <b>0</b>     |

Set FA1 (FA2) for current signal (4 ~ 20mA). This function only effects in CD44(CD45)=8,9,10,13

- 0 : NO Current Signal Application
- 1 : Current Signal in Terminal FA1
- 2 : Current Signal in Terminal FA2
- 3 : FA1 & FA2 Current Signal Terminal

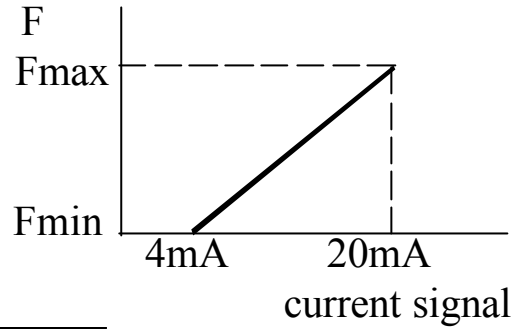

|  |
|--|
| <b>Frequency arrive<br/>signal range</b> |
| <b>CD55</b>                              |



|                        |                  |
|------------------------|------------------|
| <b>Setting Range</b>   | <b>0% ~ 100%</b> |
| <b>Factory Setting</b> | <b>10%</b>       |

JP1 selector moves to ARR connection. If running Freq is suitable the attachment lists, the MT terminal will output ON signal.

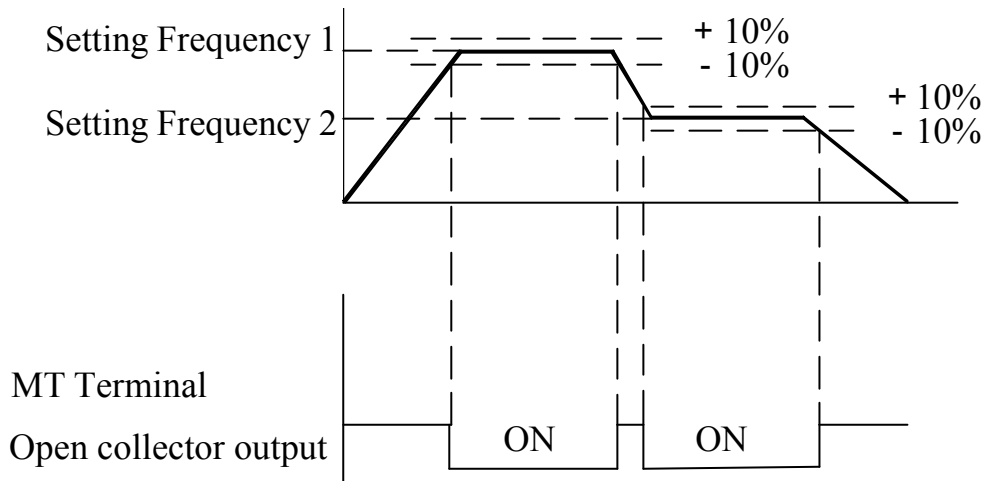
- 1.Signal output at running F. setting  $F \times (1 - CD55\%)$  for acceleration.
- 2.Signal output at running F. setting  $F \times (1 + CD55\%)$  for deceleration.



Note : When setting CD55, please follow the sequence.

1. set CD15 = 0
2. set CD55 = xx use   or  key (xx cd value)
3. set CD15 = xx (if xx > 0)

|                                      |
|--------------------------------------|
| <b>2nd Maximum Voltage frequency</b> |
| <b>CD56</b>                          |

|                        |                 |
|------------------------|-----------------|
| <b>Setting Range</b>   | <b>25 ~ 400</b> |
| <b>Factory Setting</b> | <b>120</b>      |

Set CD42(CD43)=7 define FT1(FT2) Terminal for hardware V/F curve switcher.

Open : select the 1st V/F curve preset in CD17

Close : select the 2nd V/F curve preset in CD56

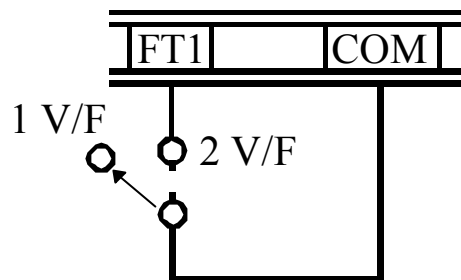
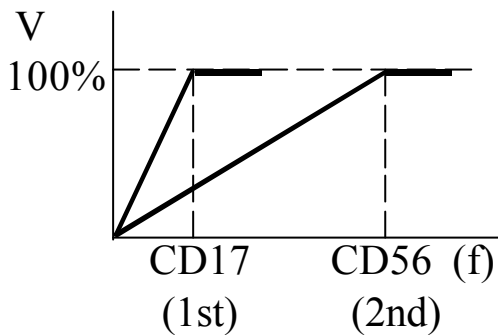

|                              |
|------------------------------|
| <b>Timer FWD/REV setting</b> |
| <b>CD57</b>                  |

|                        |               |
|------------------------|---------------|
| <b>Setting Range</b>   | <b>0 ~ 31</b> |
| <b>Factory Setting</b> | <b>0</b>      |

| CD57 setting value | Binary | CD47 | CD48 | CD49 | CD50 | CD00 |
|--------------------|--------|------|------|------|------|------|
| 31                 | 11111  | REV  | REV  | REV  | REV  | REV  |
| 30                 | 11110  | FWD  | REV  | REV  | REV  | REV  |
| 29                 | 11101  | REV  | FWD  | REV  | REV  | REV  |
| 28                 | 11100  | FWD  | FWD  | REV  | REV  | REV  |
| 27                 | 11011  | REV  | REV  | FWD  | REV  | REV  |
| 26                 | 11010  | FWD  | REV  | FWD  | REV  | REV  |
| 25                 | 11001  | REV  | FWD  | FWD  | REV  | REV  |
| 24                 | 11000  | FWD  | FWD  | FWD  | REV  | REV  |

| CD57<br>setting value | Binary | CD47 | CD48 | CD49 | CD50 | CD00 |
|-----------------------|--------|------|------|------|------|------|
| 23                    | 10111  | REV  | REV  | REV  | FWD  | REV  |
| 22                    | 10110  | FWD  | REV  | REV  | FWD  | REV  |
| 21                    | 10101  | REV  | FWD  | REV  | FWD  | REV  |
| 20                    | 10100  | FWD  | FWD  | REV  | FWD  | REV  |
| 19                    | 10011  | REV  | REV  | FWD  | FWD  | REV  |
| 18                    | 10010  | FWD  | REV  | FWD  | FWD  | REV  |
| 17                    | 10001  | REV  | FWD  | FWD  | FWD  | REV  |
| 16                    | 10000  | FWD  | FWD  | FWD  | FWD  | REV  |
| 15                    | 01111  | REV  | REV  | REV  | REV  | FWD  |
| 14                    | 01110  | FWD  | REV  | REV  | REV  | FWD  |
| 13                    | 01101  | REV  | FWD  | REV  | REV  | FWD  |
| 12                    | 01100  | FWD  | REV  | REV  | REV  | FWD  |
| 11                    | 01011  | REV  | REV  | FWD  | REV  | FWD  |
| 10                    | 01010  | FWD  | REV  | FWD  | REV  | FWD  |
| 9                     | 01001  | REV  | FWD  | FWD  | REV  | FWD  |
| 8                     | 01000  | FWD  | FWD  | FWD  | REV  | FWD  |
| 7                     | 00111  | REV  | REV  | REV  | FWD  | FWD  |
| 6                     | 00110  | FWD  | REV  | REV  | FWD  | FWD  |
| 5                     | 00101  | REV  | FWD  | REV  | FWD  | FWD  |
| 4                     | 00100  | FWD  | FWD  | REV  | FWD  | FWD  |
| 3                     | 00011  | REV  | REV  | FWD  | FWD  | FWD  |
| 2                     | 00010  | FWD  | REV  | FWD  | FWD  | FWD  |
| 1                     | 00001  | REV  | FWD  | FWD  | FWD  | FWD  |
| 0                     | 00000  | FWD  | FWD  | FWD  | FWD  | FWD  |

Note : This parameter effects in timer mode only.

|                                      |
|--------------------------------------|
| <b>Auto running mode<br/>(Timer)</b> |
| <b>CD58</b>                          |

|                        |              |
|------------------------|--------------|
| <b>Setting Range</b>   | <b>0 ~ 4</b> |
| <b>Factory Setting</b> | <b>0</b>     |

| <b>SPEED</b>         | <b>1<sup>th</sup></b> | <b>2<sup>th</sup></b> | <b>3<sup>th</sup></b> | <b>4<sup>th</sup></b> | <b>5<sup>th</sup></b> | <b>VALUE RANGE</b> | <b>UNIT</b>   |
|----------------------|-----------------------|-----------------------|-----------------------|-----------------------|-----------------------|--------------------|---------------|
| <b>SPEED SETTING</b> | <b>CD47</b>           | <b>CD48</b>           | <b>CD49</b>           | <b>CD50</b>           | <b>CD00</b>           | <b>0 ~ 400</b>     | <b>Hz</b>     |
| <b>TIMER SETTING</b> | <b>CD59</b>           | <b>CD60</b>           | <b>CD61</b>           | <b>CD62</b>           | <b>CD63</b>           | <b>0 ~ 15.00</b>   | <b>hr.min</b> |

CD12=0, use keypad to control timer

CD12=0 and CD13=2, use RS485 to control timer

CD12=1, CD42 or CD43=10, use FT1 or FT2 terminal to control timer

| <b>Value</b> | <b>Description</b>   |
|--------------|--|
| <b>0</b>     | <b>Timer disable</b>   |
| <b>1</b>     | <b>Speeds with timer for one cycle then stop</b>   |
| <b>2</b>     | <b>Speeds with timer for running continually until receive stop command</b>                                      |
| <b>3</b>     | <b>Speeds with timer for one cycle then stop. There is a stop between each speed.</b>                            |
| <b>4</b>     | <b>Speeds with timer for running continually until receive stop command. There is a stop between each speed.</b> |

FT1/FT2 “ ON” , for timer RUN.

FT1/FT2 “ OFF” , for timer STOP.

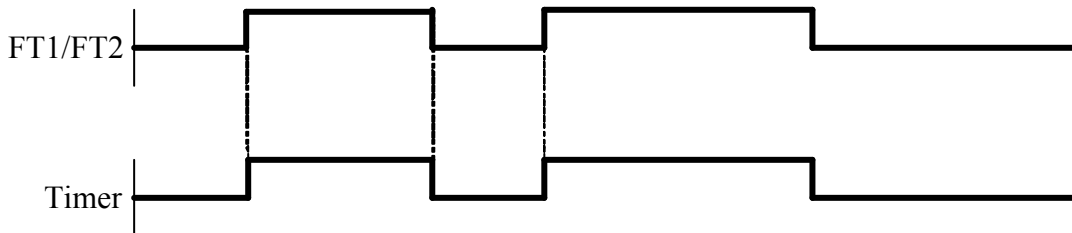

# CD58=1

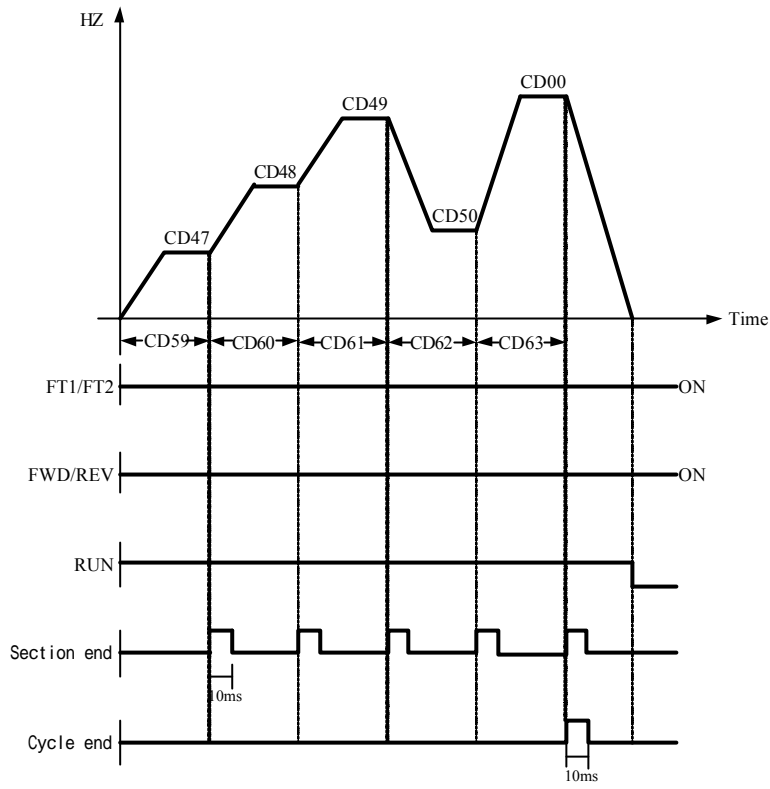

# CD58=2

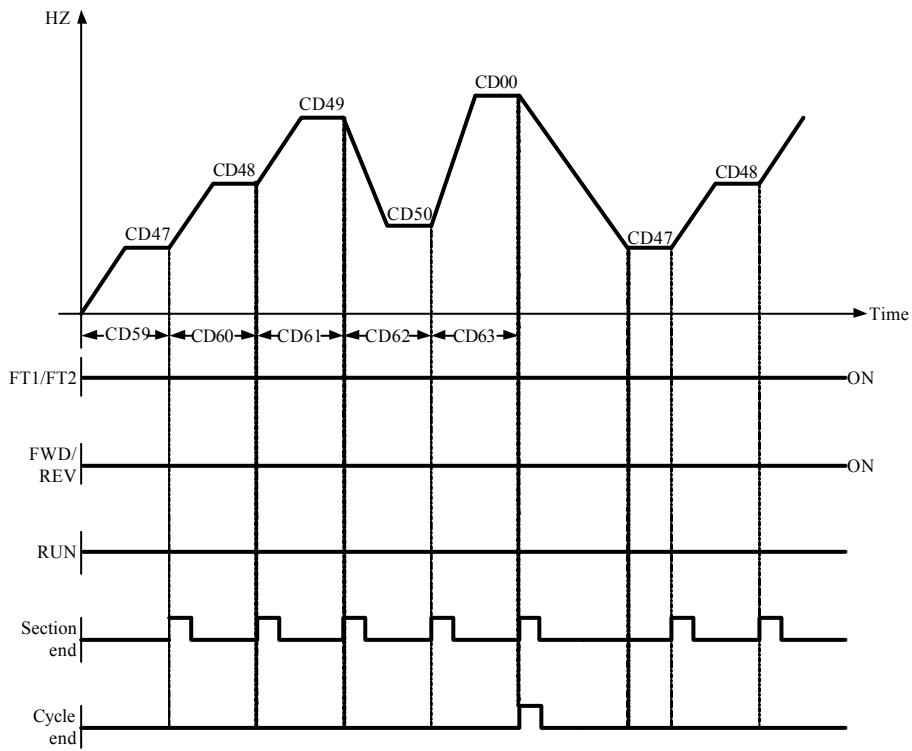

### CD58=3

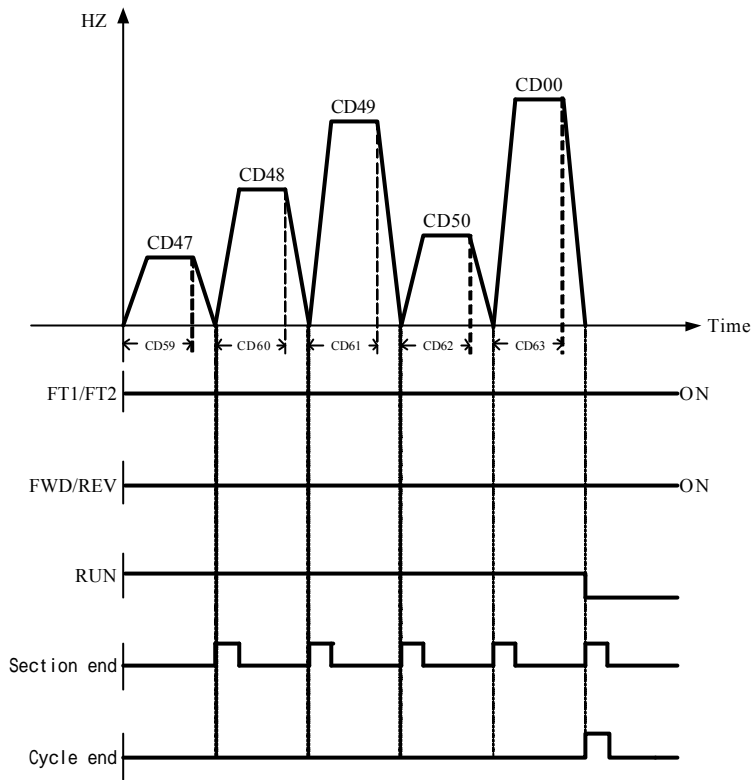

### CD58=4

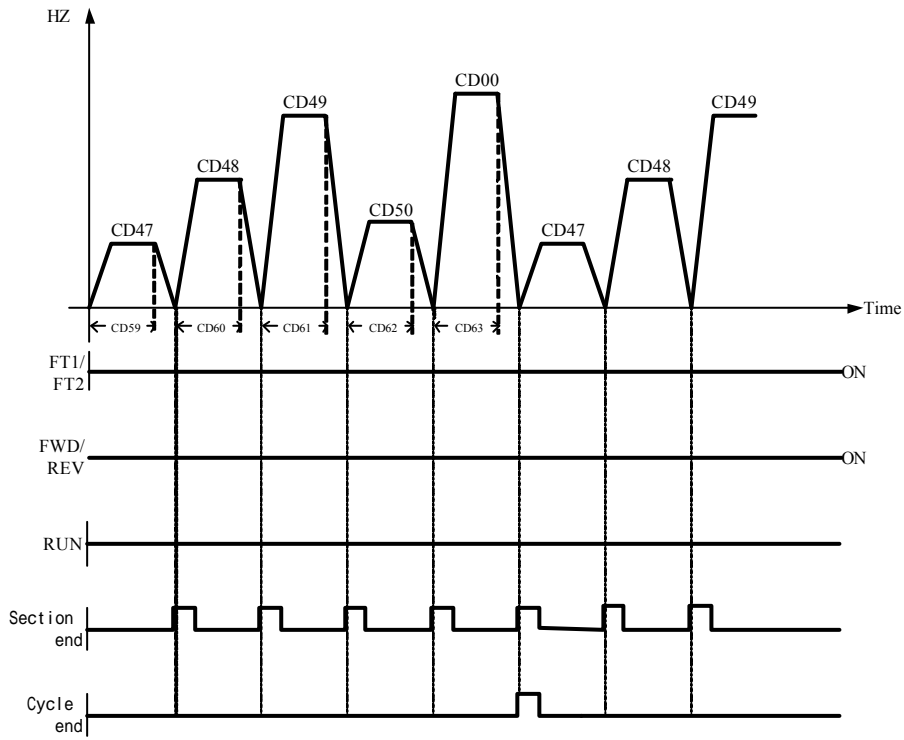

|                       |
|-----------------------|
| <b>1st step timer</b> |
| <b>CD59</b>           |

|                        |                    |
|------------------------|--------------------|
| <b>Setting Range</b>   | <b>0 ~ 15Hr</b>    |
| <b>Factory Setting</b> | <b>0.01 hr.min</b> |

Setting running time for 1th speed.(CD47)

|                       |
|-----------------------|
| <b>2st step timer</b> |
| <b>CD60</b>           |

|                        |                    |
|------------------------|--------------------|
| <b>Setting Range</b>   | <b>0 ~ 15Hr</b>    |
| <b>Factory Setting</b> | <b>0.00 hr.min</b> |

Setting running time for 2th speed.(CD48)

|                       |
|-----------------------|
| <b>3st step timer</b> |
| <b>CD61</b>           |

|                        |                    |
|------------------------|--------------------|
| <b>Setting Range</b>   | <b>0 ~ 15Hr</b>    |
| <b>Factory Setting</b> | <b>0.00 hr.min</b> |

Setting running time for 3th speed.(CD49)

|                       |
|-----------------------|
| <b>4st step timer</b> |
| <b>CD62</b>           |

|                        |                    |
|------------------------|--------------------|
| <b>Setting Range</b>   | <b>0 ~ 15Hr</b>    |
| <b>Factory Setting</b> | <b>0.00 hr.min</b> |

Setting running time for 4th speed.(CD50)

|                       |
|-----------------------|
| <b>5st step timer</b> |
| <b>CD63</b>           |

|                        |                    |
|------------------------|--------------------|
| <b>Setting Range</b>   | <b>0 ~ 15Hr</b>    |
| <b>Factory Setting</b> | <b>0.00 hr.min</b> |

Setting running time for 1th speed.(CD00)



|                            |
|----------------------------|
| <b>Timer unit selector</b> |
| <b>CD64</b>                |

|                        |              |
|------------------------|--------------|
| <b>Setting Range</b>   | <b>0 ~ 1</b> |
| <b>Factory Setting</b> | <b>0</b>     |

0 : hr.min  
1 : min.sec

|                     |
|---------------------|
| <b>RUN terminal</b> |
| <b>CD91</b>         |

|                        |              |
|------------------------|--------------|
| <b>Setting Range</b>   | <b>0 ~ 3</b> |
| <b>Factory Setting</b> | <b>0</b>     |

|                     |
|---------------------|
| <b>ARR terminal</b> |
| <b>CD92</b>         |

|                        |              |
|------------------------|--------------|
| <b>Setting Range</b>   | <b>0 ~ 3</b> |
| <b>Factory Setting</b> | <b>1</b>     |























0 : RUN(CD46).  
1 : ARR(CD55).  
2 : Section ending signal : Terminal output 10ms long signal if each speed is finished.  
3 : Cycle ending signal : Terminal output 10ms long signal if each cycle is finished.

## 7-2. Operation key-in sequence

### EXAMPLE : CHANGE acceleration time

| Setting sequence | Display indicator | Description                                      |
|------------------|-------------------|--|
|                  |                   | In waiting mode, the display is blinking         |
|                  |                   | Enter function mode                              |
|                  |                   | Select function number 1 (parameter lock)        |
|                  |                   | Press "FUNC" again to change the parameter value |
|                  |                   | Enable to change parameter                       |
|                  |                   | Save the parameter and back to waiting mode      |
|                  |                   | Enter function mode                              |
|                  |                   | Select function number 2 (acceleration time)     |
|                  |                   | Press "FUNC" again to change the parameter value |
|                  |                   | Select the first digit                           |
|                  |                   | Increase the value to 3                          |
|                  |                   | Select the second digit                          |
|                  |                   | Increase the value to 2                          |
|                  |                   | Save CD02=12.3 and back to waiting mode          |

## CHANGE maximum frequency limit

| Setting sequence  | Display indicator   | Description  |
|---|---|--|
|    |    | Enter function mode                                      |
|     |    | Increase the value to 4                                  |
|     |    | Select the second digit                                  |
|    |    | Increase the value to 1                                  |
|    |  | Press "FUNC" again to change the Maximum frequency limit |
|    |  | Select the second digit                                  |
|    |  | Decrease the value to 9                                  |
|    |  | Save CD14=90HZ and back to waiting mode                  |
|   |   |  |
|   |   |  |
|   |   |  |

## 8. DISPLAY ERROR CODES

### A. Inverter self-checking errors

|                            |
|----------------------------|
| <b>Internal protection</b> |
| <b>CPU</b>                 |

Noise protection.

Self test failure protection

|                                |
|--------------------------------|
| <b>Program check sum error</b> |
| <b>EP0</b>                     |

|                            |
|----------------------------|
| <b>EEPROM access error</b> |
| <b>EEP1</b>                |

|                               |
|-------------------------------|
| <b>EEPROM check-sum error</b> |
| <b>EEP2</b>                   |

|                               |
|-------------------------------|
| <b>Power device failure 1</b> |
| <b>PF01</b>                   |

Power device failure during acceleration

|                               |
|-------------------------------|
| <b>Power device failure 2</b> |
| <b>PF02</b>                   |

Power device failure during constant frequency

|                               |
|-------------------------------|
| <b>Power device failure 3</b> |
| <b>PF03</b>                   |

Power device failure during deceleration (stopping)

|                               |
|-------------------------------|
| <b>Power device failure 4</b> |
| <b>PF04</b>                   |

Power device failure during stand-by

## B. Operation errors

|                         |
|-------------------------|
| <b>Parameter Locked</b> |
| <b>OPE1</b>             |

To change the contents of CD02~CD52 set CD01=press  first

|                        |
|------------------------|
| <b>FWD or REV only</b> |
| <b>OPE2</b>            |

Motor direction limiter.

See function description 6.1:CD08

|                                 |
|---------------------------------|
| <b>Analog signal input only</b> |
| <b>OPE3</b>                     |

Motor speed command from control terminal only.

Input analog signal by Frequency knob

see functions description 6.1:CD10

|                              |
|------------------------------|
| <b>Terminal command only</b> |
|------------------------------|

|             |
|-------------|
| <b>OPE4</b> |
|-------------|

Accept run command from control terminal only.  
Not operation panel.  
See functions description 6.1:CD12

|                         |
|-------------------------|
| <b>Over range error</b> |
|-------------------------|

|             |
|-------------|
| <b>OPE5</b> |
|-------------|

Operating error message ~ over range.

|                            |
|----------------------------|
| <b>Logic error warning</b> |
|----------------------------|

|             |
|-------------|
| <b>OPE6</b> |
|-------------|

Logic error when setting.  
EXAMPLE : Setting F-min > F-max will result an error.

|                                |
|--------------------------------|
| <b>Only changed in standby</b> |
|--------------------------------|

|             |
|-------------|
| <b>OPE7</b> |
|-------------|

The parameter can only be changed in standby mode.

|                            |
|----------------------------|
| <b>Read only parameter</b> |
|----------------------------|

|             |
|-------------|
| <b>OPE8</b> |
|-------------|

The parameter created by system. Unable to be changed by user.

## **9. HARDWARE PROTECTIVE FUNCTION**

- (1) Over-current protection**
- (2) Short circuit protection**
- (3) Over-temperature protection**
  - A. U V W phase short protection**
  - B. Ground short protection**
- (4) Control supply under-voltage protection**
- (5) Power source under voltage**
- (6) Over voltage protection**

## **10. PRECAUTIONS**

### **10-1 Prior to maintenance, check the following :**

- (1) Before maintenance, be sure to turn the power off and wait until the LED digits vanish in the display. However, approx. 50 VDC still remains immediately after the display disappears, so wait a little bit longer.**
- (2) When removing or re-installing a connector, do not pull the cable.**
- (3) Take special care not to misplace the connector. Carefully note any disconnecting or poor contact. Be sure to tighten the terminals and connectors securely.**

### **10-2 Application precautions**

- (1) Before you start operation, thoroughly check for erroneous wiring or short circuits in the motor or in the wiring between your motor and the inverter. Do not ground the neutral point of the motor with a star connection.**
- (2) An inverter-driven run generates a certain amount of electromagnetic noise, as compared with that of driven directly by a commercial power supply. Thus you should be aware of such limitation when using an inverter-driven motor at a noise-sensitive site.**
- (3) Before setting the maximum frequency at 60HZ or higher, confirm that this operation range is acceptable with that of your motor.**
- (4) When you determine an appropriate inverter capacity, ensure that the rated current of the motor does not exceed the inverter' s rated current.**
- (5) Install a mold-case circuit breaker (MCCB) at the inverter' s power supply end to protect the wiring.**



## 11. TROUBLESHOOTING

| Display symbol | Cause of fault message contents                          | Check point  | Suggested remedy                                   |
|----------------|--|--|--|
| No display     | Discharge LED extinguished                               | Review the power system.<br>Check that MCCB has been turned on or no poor contact. | Turned on or<br>Replace MCCB                       |
| PF01           | Power device failure during acceleration                 | The acceleration time is too short.  | Increase the acceleration time                     |
|                |  | Boost voltage too high   | Reduce CD21 contents                               |
|                |  | Check the motor is locked or the load is too heavy                                 | Reduce the load factor                             |
| PF02           | Power device failure during constant frequency operation | Check for sudden change in load  | Eliminate sudden change in load                    |
|                |  | Check that the ambient temperature is too high                                     | Reduce the ambient temperature                     |
|                |  | Power supply voltage is too high.  | Reduce the voltage within specified range          |
| PF03           | Power device failure during deceleration                 | The load $GD^2$ is excessive   | Set the deceleration time suitable for load $GD^2$ |
|                |  | Power supply voltage is too high   | Reduce the voltage within specified range          |
| PF04           | Power device failure during stand-by                     | Check around the noise source.<br>Power supply voltage is too high.                | Remove the cause<br><br>Reduce the voltage         |
| EEP1           | EEPROM access error                                      | Rework with previous process. Check for the same message.                          | Repair   |
| EEP2           | EEPROM check-sum error                                   |  |  |

# 12. APPLICATION

## EXAMPLE 01 : Using variable resistor for multistage speed setting

### DESCRIPTION :

- CD10 = 1 ( Use frequency knob for 1st speed setting)
- CD12 = 1 ( External command)
- CD44 = 8 ( 2nd speed signal enter from FA1)
- SW1 = RUN / STOP
- SW2 = 1st / 2nd SPEED

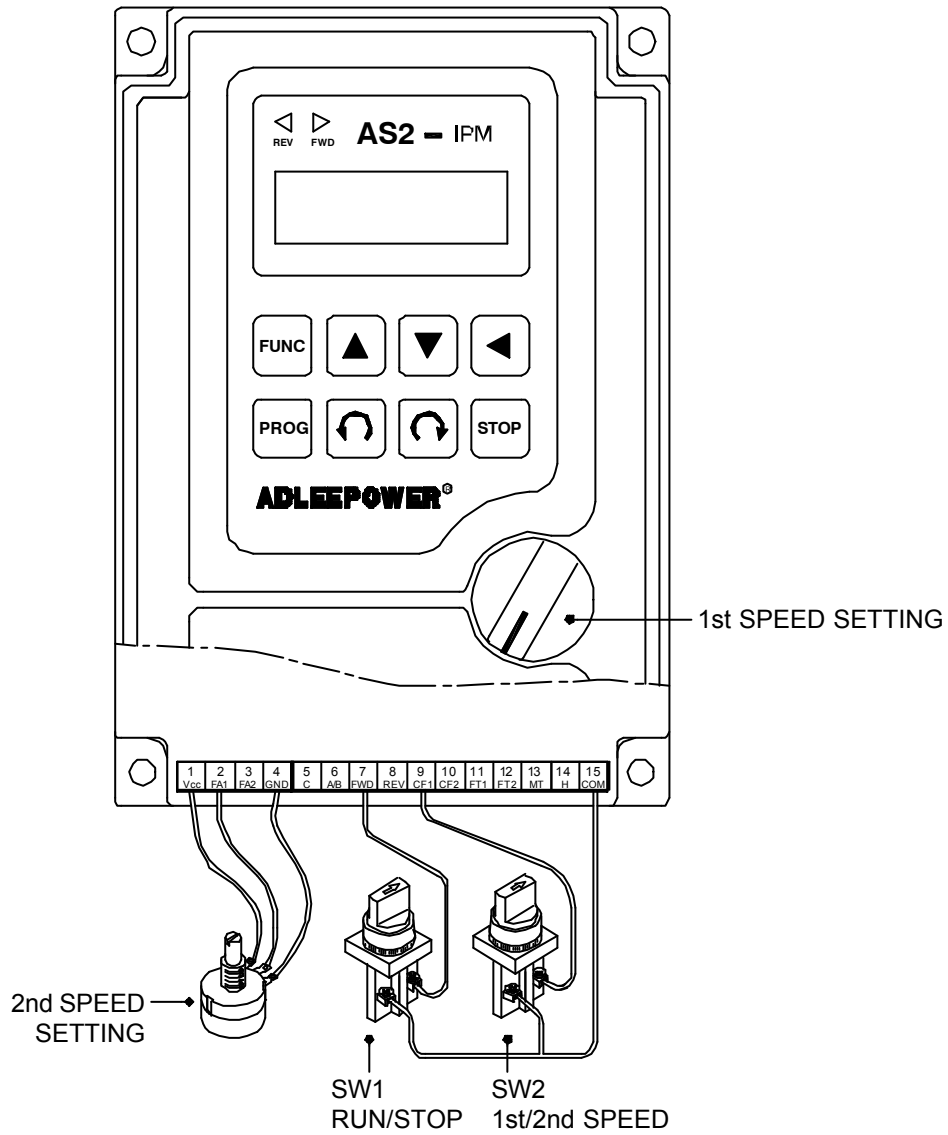

## EXAMPLE 02 : Normal / Jog operation

### DESCRIPTION :

- CD00 = Normal speed ; User setting
- CD04 = Jog speed ; User setting
- CD12 = 1 ; Terminal command (For External)
- CD42 = 1 ; Define FT1 Terminal = JOGF function
- CD43 = 2 ; Define FT2 Terminal = JOGR function

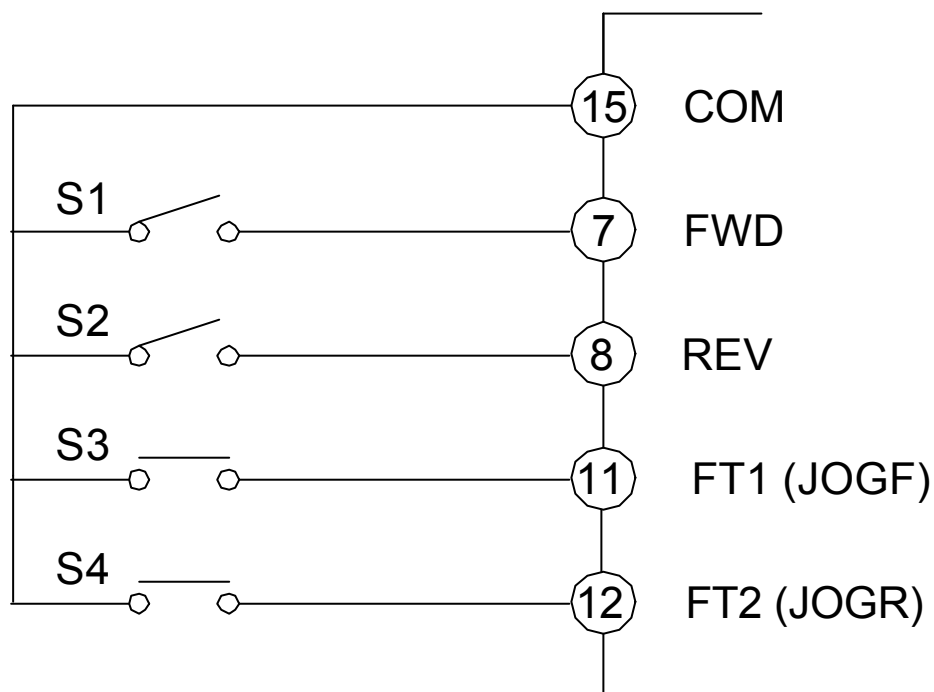

### NORMAL / JOG

- S1 = FWD SW
- S2 = REV SW
- S3 = FWD JOG SW
- S4 = REV JOG SW

**EXAMPLE 03 : Using rheostat for 3stage speed setting**

**DESCRIPTION :**

- CD12 = 1 ; Terminal command (For External)**
- CD44 = 8 ; 2nd speed signal enter from FA1**
- CD04 = 1 ; 3nd speed signal enter from FA2**

| SPEED | TERMINAL |     | SPEED COMMAND ENTRY |
|-------|----------|-----|---------------------|
|       | SW2      | SW1 |                     |
| 1     | OFF      | OFF | FREQUENCY KNOB      |
| 2     | OFF      | ON  | VR2                 |
| 3     | ON       | OFF | VR3                 |

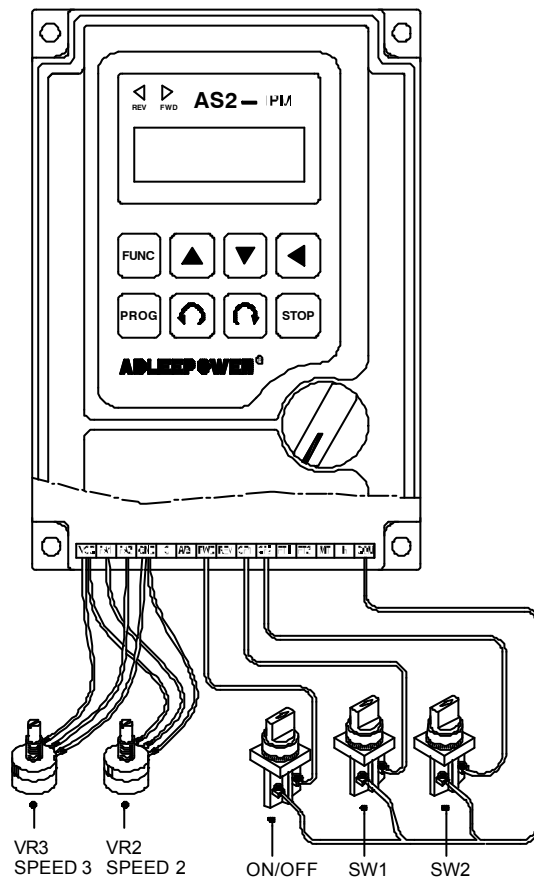

**EXAMPLE 04 : Master / slave driver system**

**DESCRIPTION : Set FA1 as 2nd speed signal input terminal.**

**Connect COM and CF1 for 2nd speed command always.**

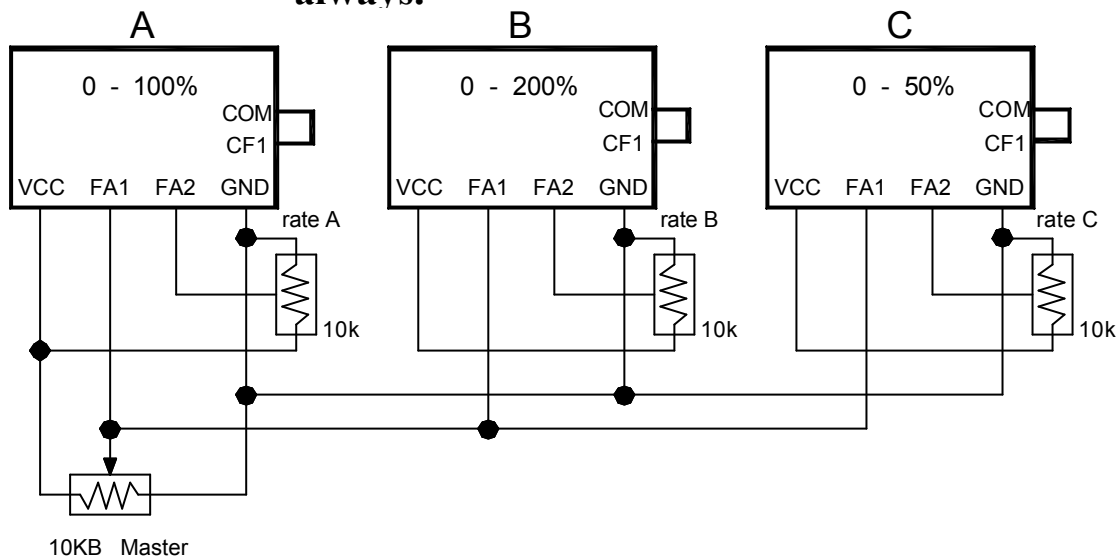

| Number           | A  | B  | C   |
|------------------|--|--|---|
| Speed rate       | 0 ~ 100%   | 0 ~ 200%   | 0 ~ 50%   |
| Function setting | CD12 = 1<br>CD14 = 100<br>CD44 = 13<br>CD45 = 11 | CD12 = 1<br>CD14 = 200<br>CD44 = 13<br>CD45 = 11 | CD12 = 1<br>CD14 = 50<br>CD44 = 13<br>CD45 = 11 |

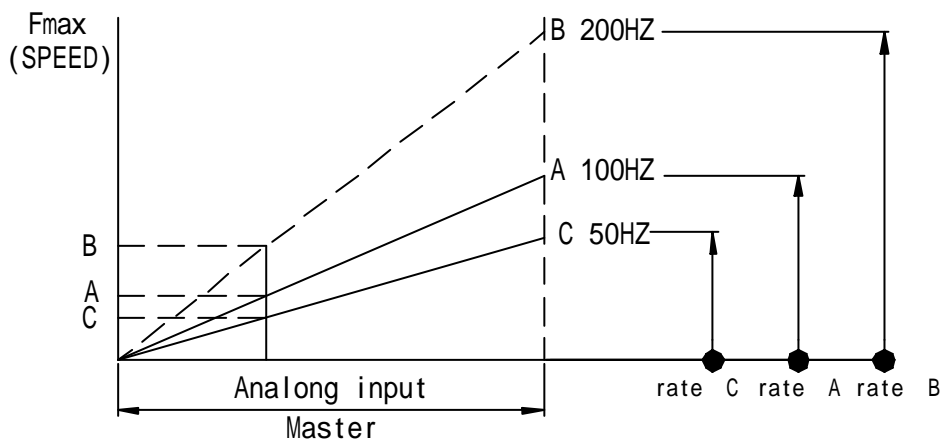

### 13. Inverter Selection

#### Inverter Capacity Check Method

| Description                               |  | Related factor   |
|---|--|--|
| Load characteristics                      | Load type  | Friction load and weight load<br>Liquid(viscous) load<br>inerita load<br>Load with power transmission and accumulation             |
|   | Load speed and torque charcteristics   | Constant torque<br>Constant power<br>Decreasing torque   |
|   | Load charcteristics  | Motoring<br>Braking or overhanging load<br>Constant load<br>Shock load<br>Repetitive load<br>High-start torque<br>Low-start torque |
| Operastion                                | Continuous operation<br>Long-time operation at medium or low speeds<br>Short-time operation  |  |
| Rated output                              | Maximum required output(instantaneous) Constant output(continuous)   |  |
| Rated rpm                                 | Maximum rpm<br>Rated rpm   |  |
| Power supply                              | Power supply transformer capacity and percentage impednace<br>Voltage fluctuations<br>Number of phases, less phase protection<br>Frequency |  |
| Deterioration of load capacity due to age | Mechanical friction, losses in wiring  |  |
|   | Duty cycle modification  |  |



# 14. APPENDIX

## A. Optional braking resistor

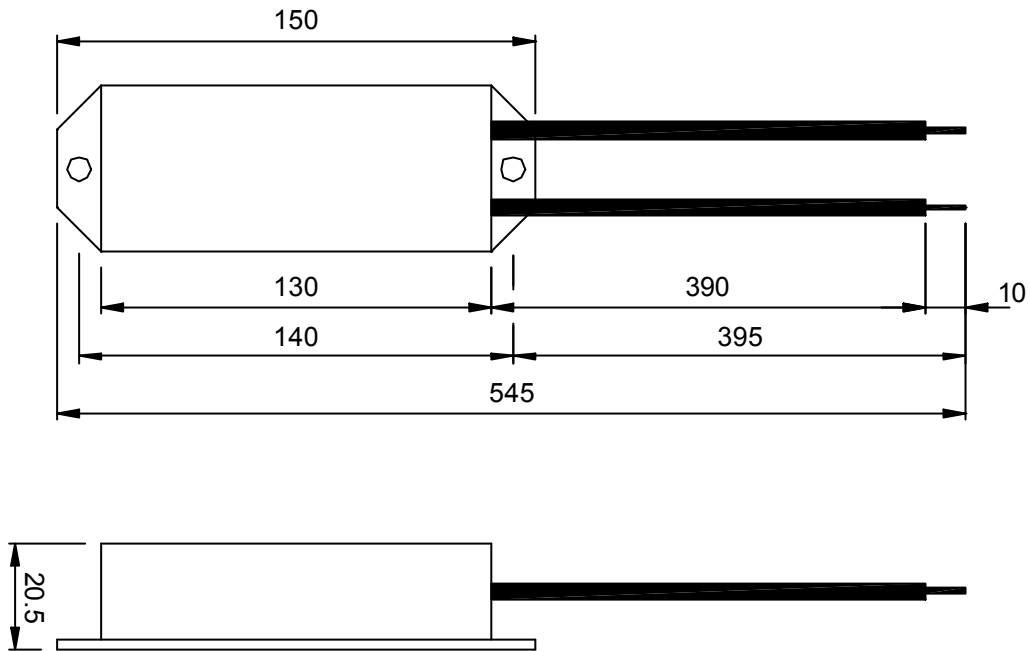

Part no : E-MSAA-008000

Specification : 60 80W

A. The resistance of braking resistor is recommended in below list.

The resistance must be larger than that shown in list.

B. Increase dynamic resistor capacity(W) when Deceleration time is setting short, or braking operation frequently.

Unit : Ohm

| Model No | 104/304 | 107/307 | 115/315 | 122/322 | 137/337 |
|----------|---------|---------|---------|---------|---------|
| AS1      | 60      | 60      | --      | --      | --      |
| AS2      | 60      | 60      | 60      | 60      | 40      |
| AS4      | 200     | 180     | 180     | 180     | 160     |



## B. Terminals wiring diagram

### 1. SINGLE PHASE

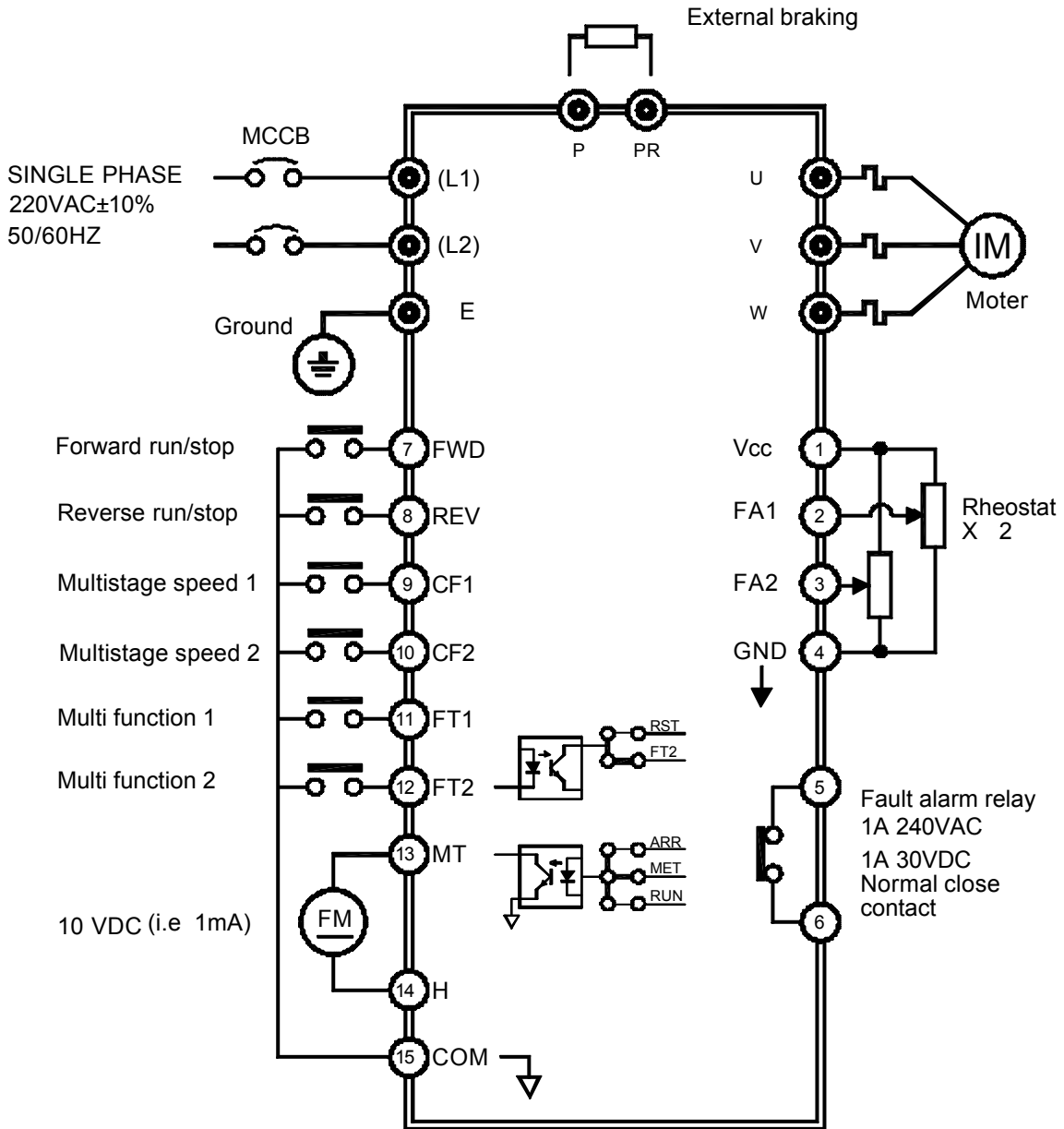

## 2. THREE PHASE

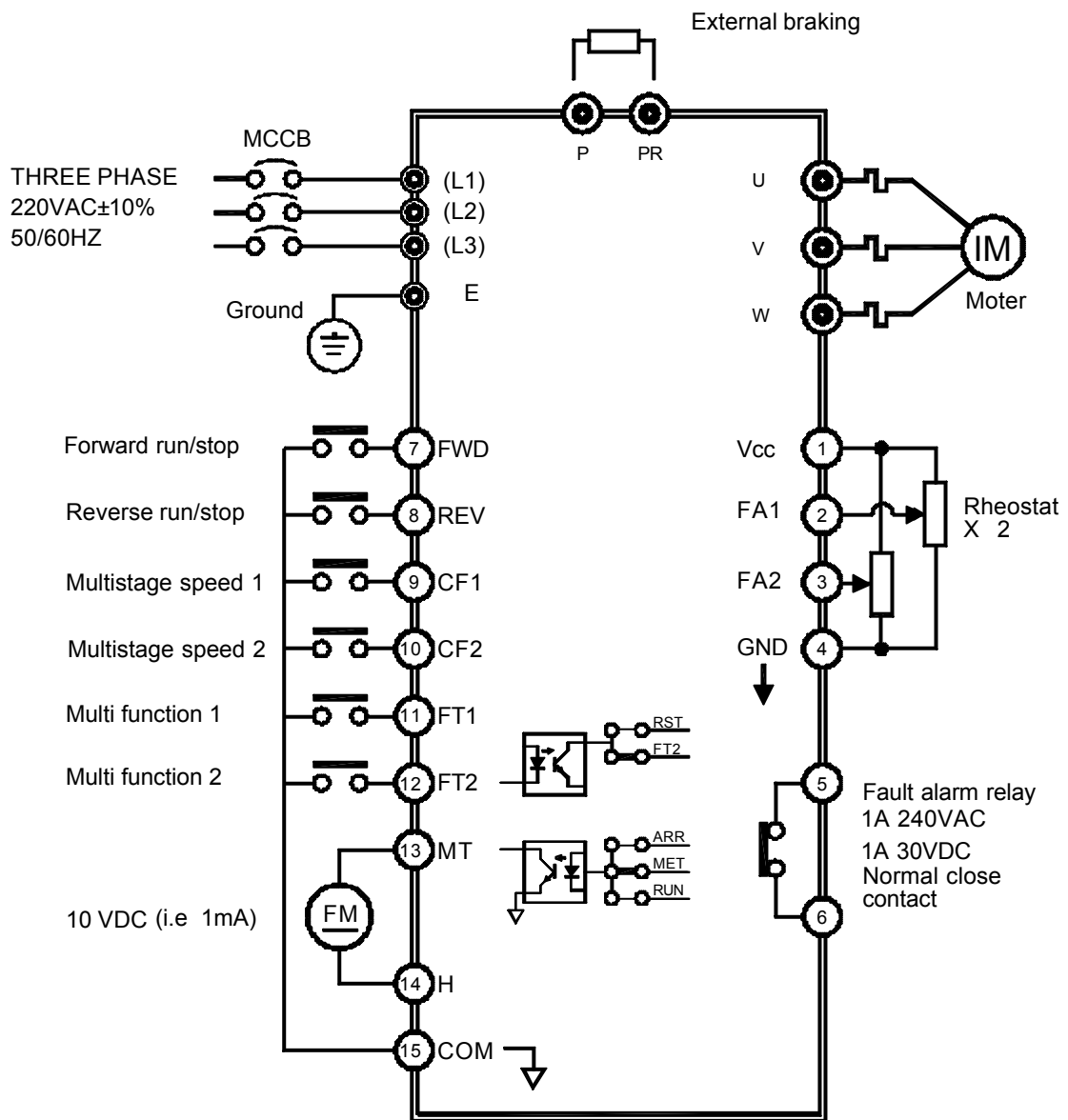

## C. Remote operator

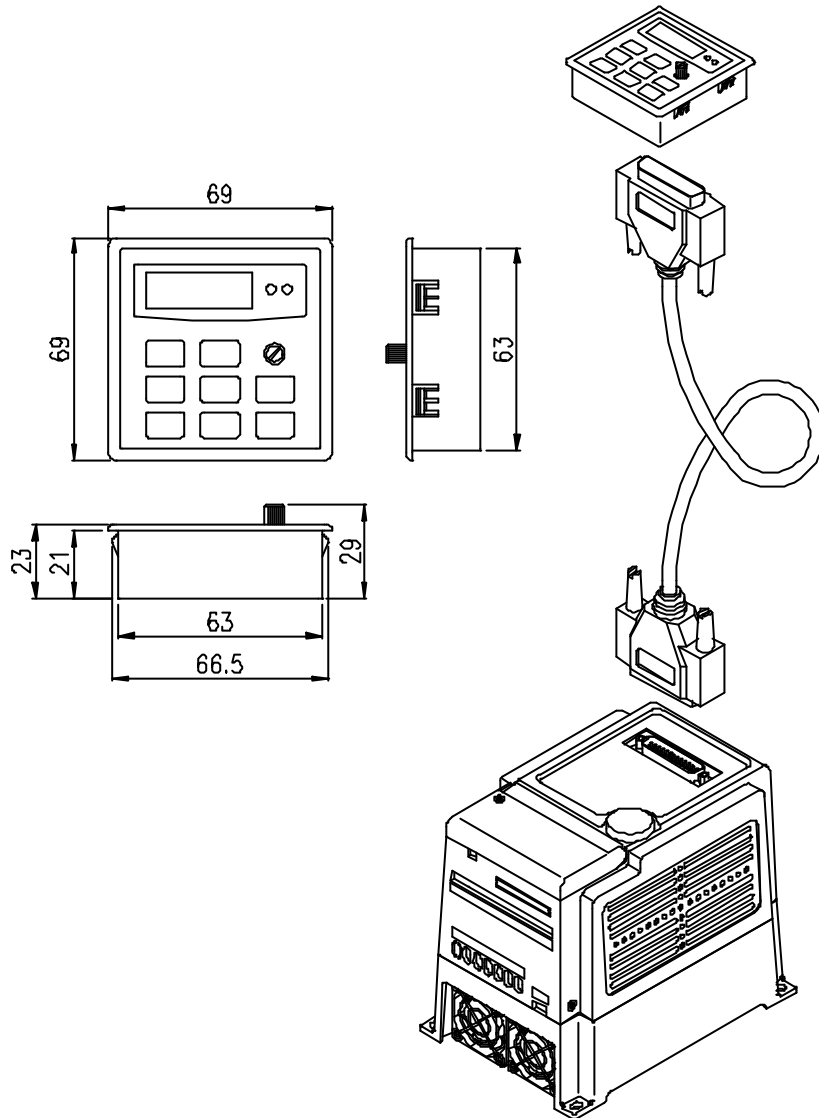

UNIT : M/M

F302 remote operator are for the remote inverters.  
Please order “R“ model inverters for remote control  
as AS2-(3)04R, AS2-(3)07R,AS2-(3)15R,  
AS2-3(22)R and mark the extension cord length.  
(1M/3M/5M)

MEMO

---

INSTRUCTION MANUAL

PART NO : E-PHAA-EASB09

Model : AS series

JAN. 2016 15<sup>st</sup> edition



**ADLEEPOWER<sup>®</sup>** SERVICE OFFICE  
FREQUENCY INVERTER MOTOR DRIVES

**Taiwan**

Tel No : 886-4-25622651

Fax No : 886-4-25628289

E-mail : [webmaster@adlee.com](mailto:webmaster@adlee.com)

URL : <http://www.adlee.com>

**Wu Han (China)**

Tel No : 86-27-88872826

Fax No : 86-27-88603986

**Guang Dong (China)**

Tel No : 86-757-26656498

Fax No : 86-757-26658515

**WUXI (China)**

Tel No : 86-51-088602669