

Preface

Thank you for purchasing the FC100 series AC drive developed by our company.

FC100 series AC drive is a compact small power AC drive. It is an economic model specialized for the small automation equipments, especially for electronic equipments, food packaging, woodworking and other applications.

FC100 Series AC Drive Features

Advanced V/F Control / Vector Control Algorithm:

Adjustable V/F Control is more stable at low speed, high torque output at low frequency and better dynamic performance.

Multiple Functions:

Multi-stage speed control, simple PLC, PID and pulse counting control.

Stable and Reliable Anti-trip Function:

Stable and reliable overvoltage/overcurrent stalling control algorithm, non-stop control function to prevent frequent trip in complex applications.

This manual describes the functions and features and correct use of FC100 series AC drive, including product selection, parameter setting, running commissioning, troubleshooting and routine maintenance and other related matters. Please read this manual carefully to make sure the correct installation and operation and maintenance to achieve the high performance of this AC drive. Please hand this manual to the users and keepers of this AC drive.

Unpacking Inspection Cautions

Every AC drive have been tested strictly in factory prior to shipment. Upon unpacking, check:

Whether the product is damaged;

Whether the nameplate model and AC drive ratings are consistent with your order.

Whether the box contains the AC drive, certificate of conformity, user manual and warranty card. If you find any omission or damage, contact our company or your supplier immediately.

First-time Use:

For the users who use this product for the first time, read the manual carefully.

If in doubt concerning some functions or performances, please contact the technical support personnel of our company to ensure correct use.

FC100 series AC drives have passed CE test and also meet the requirements of following International Standard.

IEC/EN 61800-5-1:2003 safety requirements for adjustable speed electric drive systems.

IEC/EN 61800-3:2004 adjustable speed electric drive systems: The third part: the electromagnetic compatibility standard of the product and its specific test method.

IEC/EN 61000-2-1,2-2,3-2,3-3,4-2,4-3,4-4,4-5,4-6:EMC International and EU Standard.

Contents

Preface	01
Chapter 1 Product Information	05
1.1 Naming Rules.....	06
1.2 Naming Plate.....	06
1.3 FC100 Model List.....	07
1.4 Size and Dimensions.....	07
1.5 Specifications.....	08
Chapter 2 Storage and Installation	09
2.1 Storage	10
2.2 Installation.....	11
Chapter 3 Wire Diagram and Terminal Explanation	13
3.1 Basic Wire Diagram.....	15
3.2 Terminal Explanation.....	16
3.3 Control Terminal Explanation.....	16
3.4 Main Circuit Wiring.....	17
3.5 Wire Notes	18
Chapter 4 Wire Diagram and Terminal Explanation	21
4.1 Digital Keypad Operation	22
4.2 Detailed Way For How To Use Keypad	23
Chapter 5 Function Parameters Table	25

Chapter 6 DESCRIPTION OF PARAMETER SETTINGS.....	37
Group P0: User Parameters.....	38
Group P1: Basic Parameters.....	41
Group P2: Parameters of applications.....	51
Group P3: Input and Output Function Parameters.....	53
Group P4: Secondary Application Group.....	71
Group P5: PLC Control (Special Operation).....	79
Group P6: PLC Control (Special Operation).....	84
Group P7: Modbus (RS485) Communication.....	90
Group P8: Advanced application parameters.....	97
Chapter 7 Maintenance and Inspection.....	99
Chapter 8 Troubleshooting and Fault Information.....	101



Chapter

1

Product Information

This Chapter Content

This chapter briefly introduces the operation principle, product performance, layout, nameplate, and type of instructions.

CHAPTER 1 Products Information

This FC100 AC drive has gone through rigorous quality control tests at the factory before shipment. After receiving the AC drive, please check for the following:

Receiving

Check to make sure that the package includes an AC drive, the User Manual, dust covers and rubber bushings.

Inspect the unit to insure it was not damaged during shipment.

Make sure that the part number indicated on the nameplate corresponds with the part number of your order.

1.1 Name Rules

Model code contains product information. Users can find the code on the model designation label attached to the AC drive or the simple nameplate.

FC100 – 2S – 0.7G

① ② ③

Name	Mark	Description	Detail
AC drive series	①	FC100 series	Series Name
Voltage level	②	Voltage level	2S: Single-phase 220V Range:-15%~20% 4T: Three-phase 380V Range:-15%~20%
Adaptable power	③	Adaptable motor power(KW)	0.4KW~4.0KW

1.2 Name Plates

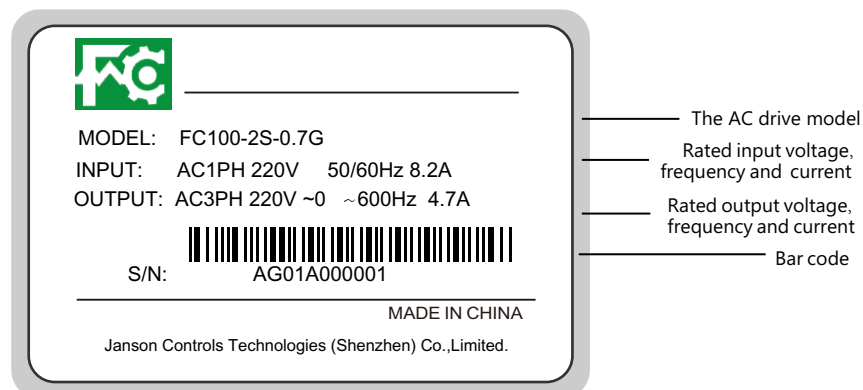

1.3 FC100 Series AC Drive

AC Drive Model	Power Capacity (KVA)	Rated Input Current (A)	Rated Output Current (A)	Adaptable Motor (KW)
Input voltage: single-phase 220V Range : -15%~20%				
FC100-2S-0.7G	1.5	8.2	4.7	0.75
FC100-2S-1.5G	3.0	14.0	7.5	1.5
FC100-2S-2.2G	4.0	23.0	10.0	2.2
Input voltage: three-phase 380V Range: -15%~20%				
FC100-4T-0.7G	1.5	3.4	2.3	0.75
FC100-4T-1.5G	3.0	5.0	3.7	1.5
FC100-4T-2.2G	4.0	5.8	5.1	2.2
FC100-4T-4.0G	5.9	10.5	8.5	4.0

1.4 Size and Dimensions

Unit: mm (inches)

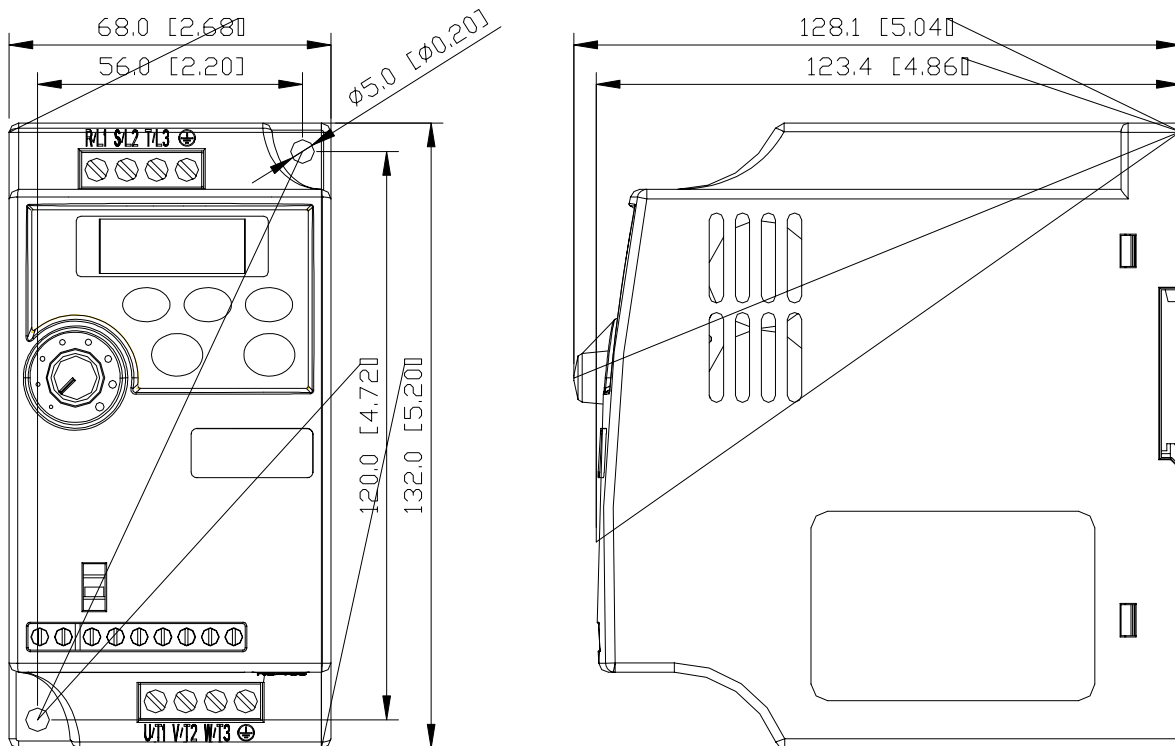

1.5 Specifications

Voltage Class		230V			
Model Number		FC100			
Applicable Motor Output (kW)		0.4	0.7	1.5	2.2
Power	Rated Frequency (Hz)	1.0~400Hz			
	Input voltage Tolerance	Single / 3-phase 180~264V 50/60Hz			
	Frequency tolerance	±5%			
Control Characteristics	Control system	SVPWM (Sinusoidal Pulse Width Modulation, carried frequency 3kHz~10kHz)			
	Output Frequency Resolution	0.1Hz			
	Torque Characteristics	Including the auto-torque, auto-slip compensation, starting torque can be 150% at 5 Hz			
	Overload Endurance	150% of rated current for 1 minute			
	Accel/Decel Time	0.1~600Sec. (can be set individually)			
	V/F pattern	V/F pattern adjustable			
	Stall Prevention Level	20~200%, setting of Rated Current			
Operating Characteristics	Frequency Setting	Keypad	Setting by		
		External Signal	Potentiometer-5KΩ/0.5W, DC 0 ~ +10V (input impedance 100KΩ), 4~20mA (output impedance 250Ω), multi-function inputs1 to 3 (3steps, JOG, UP/DOWN command), communication setting		
	Operation Setting	Keypad	Setting by RUN//STOP keys		
	Signal	External Signal	FWD,REV,S1,S2 can be combined to offer various modes of operation, RS-485 communication port		
	Multi-function Input Signal	Multi-step selection 0 to 3, Jog, accel/decel inhibit, first/second accel/decel switch, counter, PLC Operation, external Base Block (NC,NO) selection			
Multi-function Output Signal	AC Drive Operating, Frequency Attained, Non-zero speed, Base Block, Fault Indication, Local/Remote indication, PLC Operation indication.				
Other Function		AVR, S-curve, Over-Voltage Stall Prevention, DC Braking, Fault Records, Adjustable Carried Frequency, Starting Frequency Setting of DC Braking , Over-Current Stall Prevention, Momentary Power Loss restart, Reverse Inhibition, Frequency Limits, Parameter Lock/Reset			
Protection		Over Voltage, Over Current, Under Voltage, Overload, Electronic thermal, Overheating, Self-testing			
Other		Including EMI Filter			
Cooling		Forced air-cooling			
Environment	Installation Location	Altitude 1,000 m or below, keep from corrosive gasses, liquid and dust			
	Ambient Temperature	-10 -40 (Non-Condensing and not frozen)			
	Storage Temperature	-20 to 60			
	Ambient Humidity	Below 90%RH (non-condensing)			
	Vibration	9.80665m/s ² (1G) less than 20Hz, 5.88m/s ² (0.6Gat) 20 to 50Hz			



Chapter **2**

Storage and Installation

CHAPTER 2 STORAGE AND INSTALLATION

2.1 Storage

The AC drive should be kept in the shipping carton before installation. In order to retain the warranty coverage, the AC drive should be stored properly when it is not to be used for an extended period of time.

Ambient Conditions:

Operation	Air Temperature: -10°C to $+40^{\circ}\text{C}$ (14°F to 104°F) Atmosphere pressure: 86 to 106 kPa Installation Site Altitude: below 1000m Vibration: Maximum 9.86 m/s^2 (1G) at less than 20Hz Maximum 5.88 m/s^2 (1G) at 20Hz to 50Hz
Storage	Temperature: -20°C to $+60^{\circ}\text{C}$ (-4°F to 140°F) Relative Humidity: Less than 90%, no condensation allowed Atmosphere pressure: 86 to 106 kPa
Transportation	Temperature: -20°C to $+60^{\circ}\text{C}$ (-4°F to 140°F) Relative Humidity: Less than 90%, no condensation allowed Atmosphere pressure: 86 to 106 kPa Vibration: Maximum 9.86 m/s^2 (1G) at less than 20Hz, Maximum 5.88 m/s^2 (1G) at 20Hz to 50Hz
Pollution Degree	2: good for a factory type environment.

2.2 Installation:

⚠ CAUTION

The control, power supply and motor leads must be laid separately. They must not be fed through the same cable conduit / trunking.
 High voltage insulation test equipment must not be used on cables connected to the drive.

Improper installation of the AC drive will greatly reduce its life. Be sure to observe the following precautions when selecting a mounting location.

Failure to observe these precautions may void the warranty!

Do not mount the AC drive near heat-radiating elements or in direct sunlight.

Do not install the AC drive in a place subjected to high temperature, high humidity, excessive vibration, corrosive gases or liquids, or airborne dust or metallic particles.

Mount the AC drive vertically and do not restrict the air flow to the heat sink fins.

The AC drive generates heat. Allow sufficient space around the unit for heat dissipation.

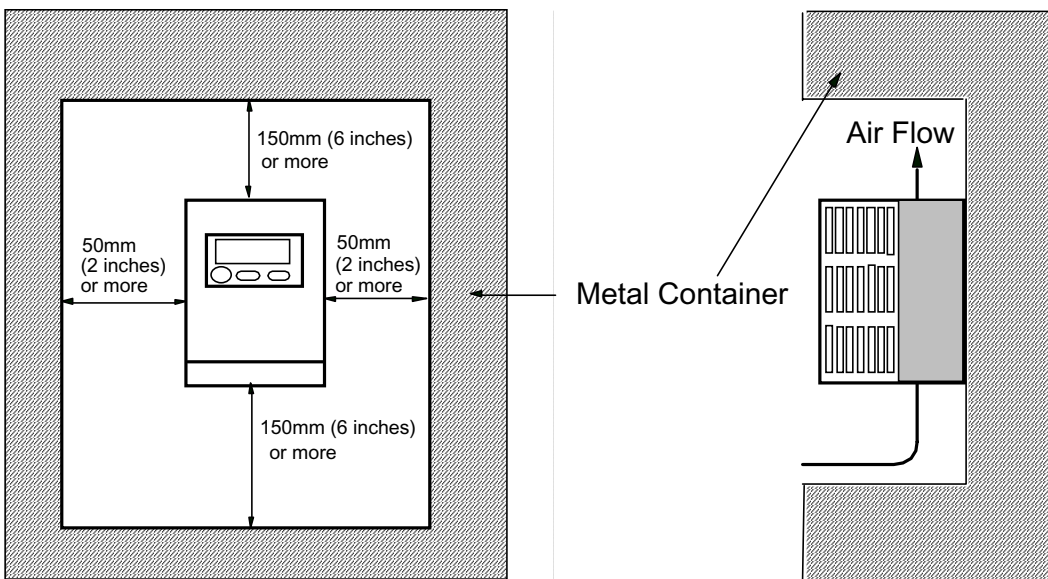

Minimum Clearances and Air Flow



Chapter **3**

Wiring Diagram and Terminal Explanation

CHAPTER 3 WIRING Diagram and Terminal Explanation



DANGER

Hazardous Voltage

Before accessing the AC drive:

Disconnect all power to the AC drive.

Wait five minutes for DC bus capacitors discharge.

Any electrical or mechanical modification on to this equipment without prior written consent of Delta Electronics, Inc. will void all warranties and may result in a safety hazard in addition to voiding the UL listing.

3.1 Basic Wiring Diagram

Users must connect wiring according to the circuit diagram shown below. Please follow all National and State wiring codes, when wiring the FC100.

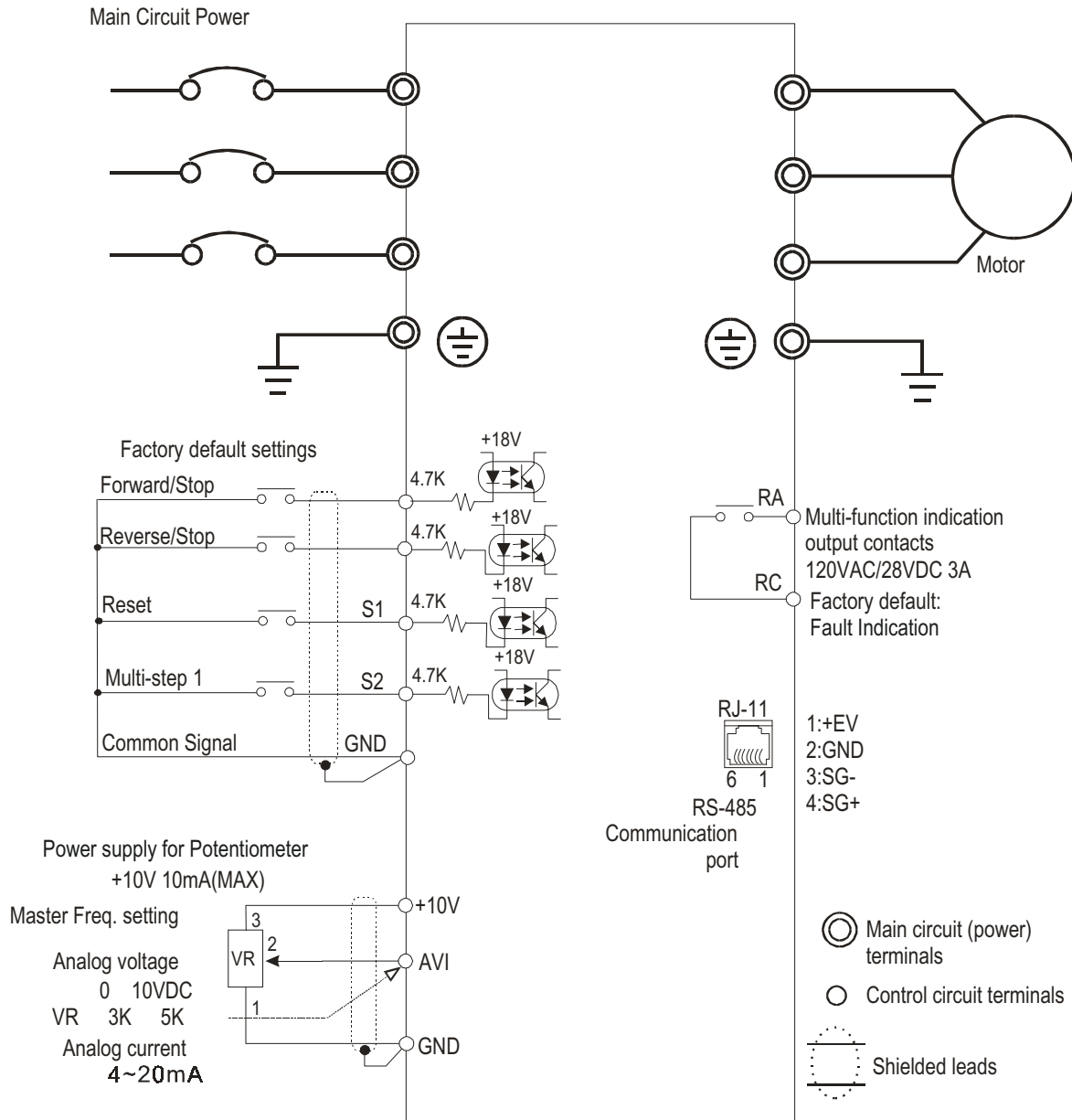

NOTE: Do not plug in a Modem or telephone line to the RS-485 communication port, permanent damage may result. Terminals 1 & 2 are the power source for the optional copy keypad and should not be used while using RS-485 communication.

*

3.2 Terminal Explanations

Terminal Symbol	Explanation of Terminal Function
R/L1, S/L2, T/L3	AC line input terminals
U/T1, V/T2, W/T3	AC drive output terminals motor connections
	Earth Ground

3.3 Control Terminals Explanations

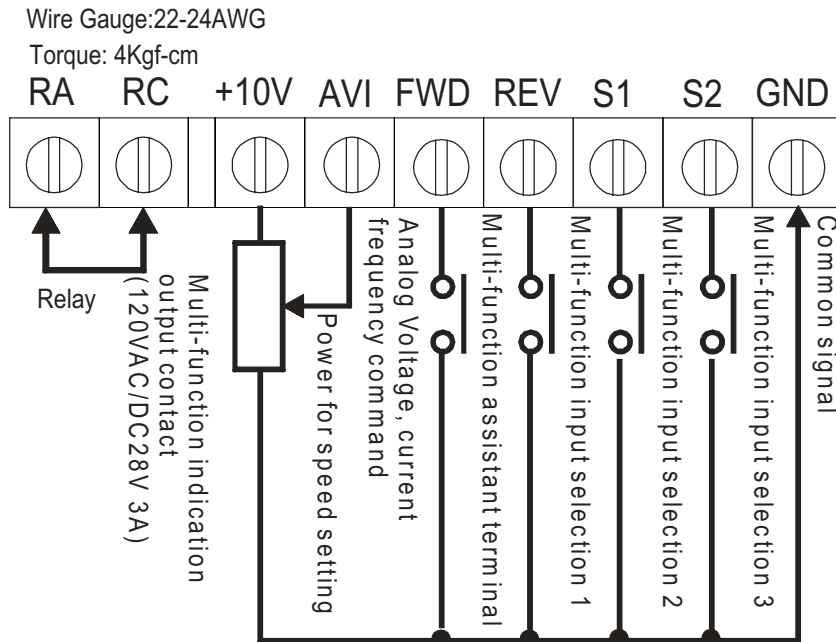

Terminal Symbols	Terminal Functions	Factory Settings
FWD	Multi-function Input 0	Refer to P315 to P318 Multi-function Input Terminals
REV	Multi-function Input 1	
S1	Multi-function Input 2	
S2	Multi-function Input 3	
RA	Multi-function Relay output (N.O.) a	120Vac, 3A 24Vdc, 3A
RC	Multi-function Relay common	Refer to Pr.03-03
+10V	Potentiometer power source	+10V 20mA
AVI	Analog voltage/ Input current	0 to +10V / 4 to 20mA

* Control signal wiring size: 22-24 AWG (0.3-0.2 mm²).

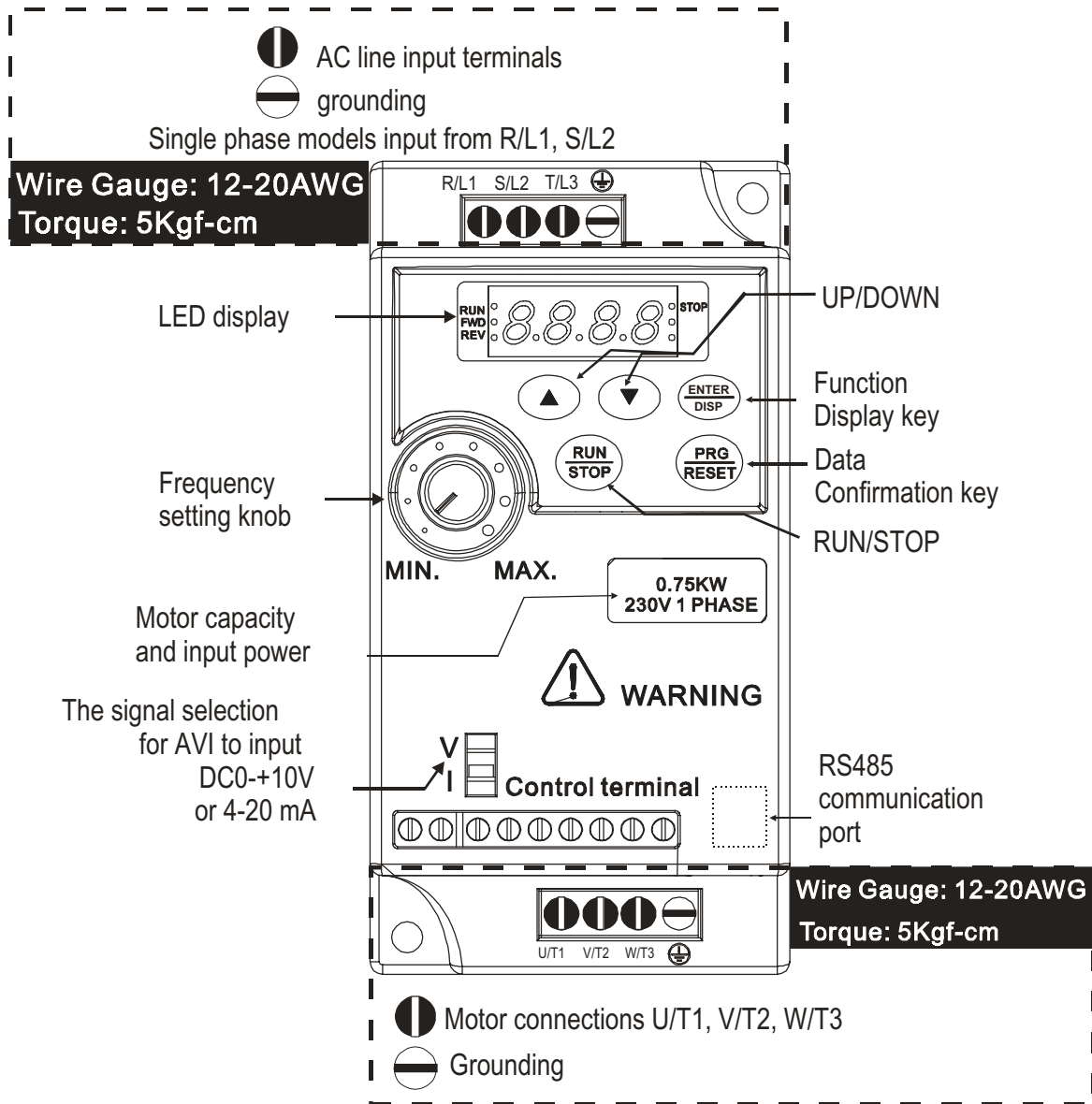

3.4 Main Circuit Wiring



Control Terminal
 Torque: 4Kgf-cm (3 in-lbf)
 Wire: 22-24 AWG

Power Terminal
 Torque: 5Kgf-cm (4.33 in-lbf)
 Wire: 12-20 AWG

3.5 Wiring Notes: PLEASE READ PRIOR TO INSTALLATION.

1.  CAUTION: Do not connect the AC power to the U/T1, V/T2, W/T3 terminals, as it will damage the AC drive.
2.  WARNING: Ensure all screws are tightened to the proper torque rating.
3. During installation, follow all local electrical, construction, and safety codes for the country the drive is to be installed in.
4. Ensure that the appropriate protective devices (circuit breaker or fuses) are connected between the power supply and AC drive.
5. Make sure that the leads are connected correctly and the AC drive is properly grounded. (Ground resistance should not exceed 0.1 Ω.)
6. Use ground leads that comply with AWG/MCM standards and keep them as short as possible.
7. Multiple FC100 units can be installed in one location. All the units should be grounded directly to a common ground terminal. The FC100 ground terminals may also be connected in parallel, as shown in the figure below. Ensure there are no ground loops.

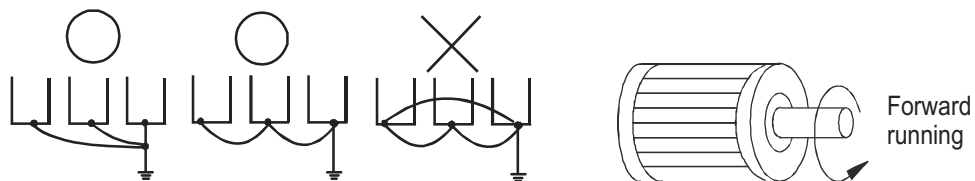

8. When the AC drive output terminals U/T1, V/T2, and W/T3 are connected to the motor terminals U/T1, V/T2, and W/T3, respectively, the motor will rotate counterclockwise (as viewed from the shaft ends of the motor) when a forward operation command is received. To reverse the direction of motor rotation, switch over any of the two motor leads.
9. Make sure that the power source is capable of supplying the correct voltage and required current to the AC drive.
10. Do not attach or remove wiring when power is applied to the AC drive.

11. Do not monitor the signals on the circuit board while the AC drive is in operation.
12. For the single-phase rated AC drives, the AC power can be connected to any two of the three input terminals R/L1, S/L2, T/L3. Note: This drive is not intended for the use with single-phase motors.
13. Route the power and control wires separately, or at 90° angle to each other.
14. If a filter is required for reducing EMI (Electro Magnetic Interference), install it as close as possible to AC drive. EMI can also be reduced by lowering the Carrier Frequency.
15. If the AC drive is installed in the place where a load reactor is needed, install the filter close to U/T1, V/T2, W/T3, side of AC drive. Do not use a Capacitor or L-C Filter (Inductance-Capacitance) or R-C Filter (Resistance-Capacitance), unless approved by Delta.
16. When using a GFCI (Ground Fault Circuit Interrupt), select current sensor with sensitivity of 200mA, and not less than 0.1-second detection to avoid nuisance tripping.



Chapter 4

Keypad Operation

CHAPTER 4 DIGITAL KEYPAD OPERATION

4.1 Description of Digital Keypad

This digital keypad includes two parts: Display panel and keypad. Display panel provides the parameter display and shows operation status of the AC drive. Keypad provides programming interface between users and AC drives.

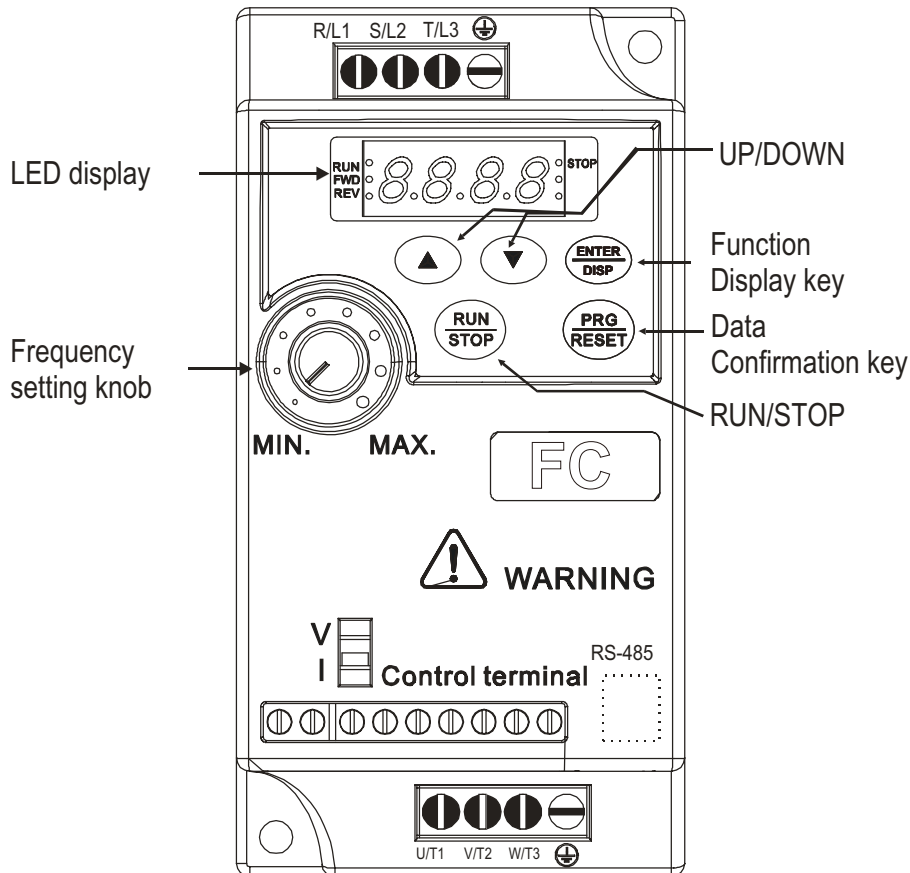

ENTER/DISP

Shift / Enter / Switch Display Button

shift to another digit or switch to another display by short-pressing, confirm a setting by long-pressing



PRG/RESET

Program key / fault reset button

short press for programming key, press 2 seconds for the result button



Run/Stop

Press to Start or Stop the AC drive operation. This key can only be used to Stop the AC Drive when the drive is controlled by the External Control Terminals.



Chapter 5

Function Parameters Table

CHAPTER 5 Function Parameters Table

Parameters		Name	Setting Range	Minimum Setting increments	Initial value
Monitor Function	P000	Main display data selection	0-32	1	1
	P001	Display the set frequency	Read only		
	P002	Display the output frequency	Read only		
	P003	Display the output current	Read only		
	P004	Display the motor speed	Read only		
Monitor Function	P005	Display the DC bus voltage value	Read only		
	P006	Display the temperature of inverter	Read only		
	P007	Display PID	Read only		
	P010	Alarm record 1	Read only		
	P011	Alarm record 2	Read only		
	P012	Alarm record 3	Read only		
	P013	Alarm record 4	Read only		
	P014	The frequency setting in the last alarm	Read only		
	P015	The output frequency in last alarm	Read only		
	P016	The output current last alarm	Read only		
	P017	The output voltage in last alarm	Read only		
	P018	The output DC bus voltage in last alarm	Read only		

Parameters		Name	Setting Range	Minimum Setting increments	Initial value
Basic Function	P100	Digital frequency setting	0.00~Maximum	0.1	0.0
	P101	Frequency setting selection	0: Digital frequency setting (P100) 1: Analog voltage (0~ 10VDC) 2: Analog current (0~20mADC) 3: Setting dial (Operation panel) 4 UP/DOWN frequency setting 5: RS485 communication frequency setting	1	3
	P102	Start signal selection	0: Operation panel (FWD/REV/ STOP) 1: I/O terminal 2: Communication (RS485)	1	0
	P103	“stop” key lock operation selection	0: “Stop” key lock mode invalid 1: “Stop” key lock mode valid	1	1
	P104	Reverse rotation prevention selection	0: Reverse rotation disallowed 1: Reverse rotation allowed	1	1
	P105	Maximum frequency	Minimum~400.00Hz	0.1	50.0
	P106	Minimum frequency	0.00 ~Maximum	0.1	0.00
	P107	Acceleration time 1	0~999.9s	0.1	Depends on models
	P108	Deceleration time 1	0~999.9s	0.1	
	P109	V/F maximum voltage	V/F intermediate voltage ~ 500.0V	0.1	

Parameters	Name	Setting Range	Minimum Setting increments	Initial value	
Basic Function	P110	V/F base frequency	V/F intermediate frequency ~ max. frequency	0.1	0.0
	P111	V/F intermediate voltage	V/F minimum voltage ~ V/F maximum voltage	0.1	Changing
	P112	V/F intermediate frequency	V/F minimum frequency ~ V/F base frequency	0.01	2.50
	P113	V/F minimum voltage	0~V/F intermediate voltage	0.1	15.0
	P114	V/F minimum frequency	0~V/F intermediate frequency	0.1	1.2
	P115	Carrier frequency	1.0K~15.0K	0.1	Changing
	P116	Automatic carrier line up	Reserved	1	0
	P117	Initialization of parameters	8: Initialization of Factory Setting	1	0
	P118	Parameter lock	0:Unlock parameters 1: Lock up parameters	1	0
	P200	Start mode selection	0: regular start 1: restart after inspection	1	0
	P201	Stop mode selection	0: deceleration to a stop 1: coasting	1	0
	P202	Starting frequency	0.10~10.00Hz	0.01	0.5
	P203	Stopping frequency	0.10~10.00Hz	0.01	0.5
	P204	DC injection brake operation current (start)	0~150% rated motor current	1%	50%
	P205	DC injection brake operation time (start)	0~25.0S	0.1	0
	P206	DC injection brake operation current (stop)	0~150% rated motor current	1%	60%
	P207	DC injection brake operation time (stop)	0~25.0S	0.1	0
	P208	Torque boost	0~20.0%	1	0%
	P209	Rated motor voltage	0~500.0V	0.1	Changing
	P210	Rated motor current	0~current of system	0.1	Changing

Parameters		Name	Setting Range	Minimum Setting increments	Initial value
	P211	No load current ratio of motor	0~100%	0.1	40%
	P212	Rated motor rotation speed	0~6000r/min	1	1420
	P213	Number of motor poles	0~20	2	4
	P214	Rated motor slip	0~10.00Hz	0.1	2.50
	P215	Rated motor frequency	0~400.0Hz	0.1	50.00
	P216	Resistance of stator	0~100	0.1	2
	P217	Resistance of rotor	0~100	0.1	4.5
	P218	Self inductance of rotor	0~1.000H	0.1	1
	P219	Mutual inductance of rotor	0~1.000H	0.1	0.2
I/O Function	P300	AVI minimum voltage input	0~AV maximum voltage	0.1	10
	P301	AVI maximum voltage input	AV minimum voltage~10V	0.1	10.0
	P302	AVI input filter time	0~25.0S	0.1	1.0
	P303	AVI minimum current input	0~AI maximum current	0.1	4.0
	P304	AVI maximum current	AI minimum current input ~20mA	0.1	20.0
	P305	AVI input filter time	0~25.0S		2.5
	P306	Reserved			
	P307	Reserved			
	P310	Frequency of low analog	0~400.0	0.1	0.00
	P311	Direction of low analog	0/1	1	0
	P312	Frequency of high analog	0~400.0	0.1	50.00
	P313	Direction of high analog	0/1	1	0
	P314	Analog input reverse selection	0/1	1	0
	P315	Input terminal FWD (0~32)		1	6
P316	Input terminal REV (0~32)		1	7	
P317	Input terminal SI (0~32)		1	18	

Parameters		Name	Setting Range	Minimum Setting increments	Initial value
I/O Function	P318	Input terminal S2 (0~32)	0: Invalid 1: Jog 2: Jog Forward 3: Jog reverse 4: Forward/ reverse 5: Run 6: Forward 7: Reverse 8: Stop 9: Multi -speed 1 10: Multi -speed 2 11: Multi -speed 3 12: Multi -speed 4 13: Acceleration /Deceleration	1	9
	P319	Reserved		1	
	P320	Reserved		1	
	P321	Reserved		1	
	P322	Reserved		1	
	P323	Reserved			
	P324	Reserved			
	P325	Alarm output terminal RA,RC(0~32)	0: Invalid 1: In running 2: Frequency reached 3: Alarm 4: Zero speed 5: Frequency 1 reached 6: Frequency 2 reached 7: Acceleration 8: Deceleration 9: Indication for under voltage 10: Timer 1 reached 11: Timer 2 reached 12: Indication for completion of phase 13: Indication for completion of procedure 14: PID maximum 15: PID minimum 16: 4~20mA disconnection 17: Overload 18: Over torque 26: Winding operation completed 27: Counter reached 28: Intermediate counter reached 29: Water supply by constant voltage "1" turn on "0" turn off	1	03
P400	Jog frequency setting	0.00~maximum frequency	0.1	5.0	
P401	Acceleration time 2	0~999.9s	0.1S	10.0	
P402	Deceleration time 2	0~999.9s	0.1S	10.0	
P403	Acceleration time 3	0~999.9s	0.1S	10.0	

Parameters	Name	Setting Range	Minimum Setting increments	Initial value	
Secondary Application	P404	Acceleration time 3	0~999.9s	0.1S	10.0
	P405	Acceleration time 4/Jog acceleration time	0~999.9s	0.1S	10.0
	P406	Deceleration time 4/Jog deceleration time	0~999.9s	0.1S	10.0
	P407	Designated value of counter	0~999.9s	1	100
	P408	Intermediate value of counter	0~999.9s	1	50
	P409	Limitation of acceleration torque	0~200%	1%	150%
	P410	Limitation of constant speed toxiue	0~200%	1%	00
	P411	Overvoltage prevention selection in deceleration	0/1	1	1
	P412	Automatic Voltage regulation selection	2	1	1
	P413	Automatic energy saving selection	0~100%	1%	00
	P414	Reverse			
	P415	Reverse			
	P416	Restart after instant power off	0~1	1	0
	P417	Allowable time of power cut	0~10s	1	5.0S
	P418	Flank restart Current limited level	0~200%	1	150%
	P419	Flank restart time	0~10s	1	10
	P420	Fault restart times	0~5s	1	0
	P421	Delay time for restart after feult	0~100	2	2
	P422	Over torque action	0~3	1	0
	P423	Over torque detection level	0~200%	1	00
	P424	Over torque detection time	0~20.0S	0.1	00
	P425	Reaching Frequency 1	0.00~maximum frequency	0.1	0
	P426	Reaching Frequency 2	0~maximum frequency	0.1	0

Parameters		Name	Setting Range	Minimum Setting increments	Initial value
	P427	Timer 1 setting	0~10.0s	0.1	0
	P428	Timer 2 setting	0~100s	1	0
	P429	Constant speed torque limiting time	0~999.9s	0.1	Changing
	P430	Width of arrival of frequency in hysteretic loop	0~2.0	0.1	0.50
	P431	Jump frequency 1	0~maximum frequency	0.1	0
	P432	Jump frequency 2	0~maximum frequency	0.1	0
	P433	Jump frequency hysteresis loop width	0~2.0	0.1	0.50
	P434	UP/DOWN frequency step	0~10.0Hz	0.1	0.1
	P435	UP/DOWN frequency Memory options	0: Memory 1: No Memory	1	0
PLC Operation	P500	PLC memory mode	0~1	1	0
	P501	PLC starting mode	0~1	1	0
	P502	PLC running mode	0: PLC stops after running for one cycle 1: PLC stop mode, it stops after running for one cycle 2: PLC cycle running 3: PLC stop mode, cycle running mode 4: PLC operates at &e last frequency after running for one cycle.	1	0
	P503	Multi speed 1	0.00~maximum frequency	0.1	20.0
	P504	Multi speed 2	0.00~maximum frequency	0.1	10.0
	P505	Multi speed 3	0.00~maximum frequency	0.1	20.0
	P506	Multi speed 4	0.00~maximum frequency	0.1	25.0
	P507	Multi speed 5	0.00~maximum frequency	0.1	30.0
	P508	Multi speed 6	0.00~maximum frequency	0.1	35.0
P509	Multi speed 7	0.00~maximum frequency	0.1	40.0	

Parameters	Name	Setting Range	Minimum Setting increments	Initial value	
PLC Operation	P510	Multi speed 8	0.00~maximum frequency	0.1	45.0
	P511	Multi speed 9	0.00~maximum frequency	0.1	50.0
	P512	Multi speed 10	0.00~maximum frequency	0.1	10.0
	P513	Multi speed 11	0.00~maximum frequency	0.1	10.0
	P514	Multi speed 12	0.00~maximum frequency	0.1	10.0
	P515	Multi speed 13	0.00~maximum frequency	0.1	10.0
	P516	Multi speed 14	0.00~maximum frequency	0.1	10.0
	P517	Multi speed 15	0.00~maximum frequency	0.1	10.0
	P518	PLC operation time 1	0~9999s	1S	100
	P519	PLC operation time 2	0~9999s	1S	100
	P520	PLC operation time 3	0~9999s	1S	100
	P521	PLC operation time 4	0~9999s	1S	100
	P522	PLC operation time 5	0~9999s	1S	0
	P523	PLC operation time 6	0~9999s	1S	0
	P524	PLC operation time 7	0~9999s	1S	0
	P525	PLC operation time 8	0~9999s	1S	0
	P526	PLC operation time 9	0~9999s	1S	0
	P527	PLC operation time 10	0~9999s	1S	0
	P528	PLC operation time 11	0~9999s	1S	0
	P529	PLC operation time 12	0~9999s	1S	0
	P530	PLC operation time 13	0~9999s	1S	0
	P531	PLC operation time 14	0~9999s	1S	0
	P532	PLC operation time 15	0~9999s	1S	0
	P533	PLC operation direction	0~9999s	1S	0

Parameters		Name	Setting Range	Minimum Setting increments	Initial value
PID Operation	P600	PID starting mode	0: PID disable 1: PID start 2: PID start by external terminal	1	0
	P601	PID operation mode selection	0: Negative feedback mode 1: Positive feedback mode	1	0
	P602	PID action set point	0: figure mode (P604) 1: AVI(0~10V) 2: AVI (0~20mA)	1	0
	P603	PID feedback value selection	0:AVI(0~10V) 1:AVI(0~20mA)	1	0
	P604	PID figure target value setting	0~100.0%	0.1%	50%
	P605	PID upper limit alarm value	0~100.0%	1%	100%
	P606	PID lower limit alarm value	0~100.0%	1%	0%
	P607	PID proportional band	0~200.0%	0.1%	100%
	P608	PID integral time	0.00.0~20.00 S. " 0" means closed	0.1s	0.3s
	P609	PID differential time	0.00.0~20.00 S. " 0" means closed	0.1s	0.0 -
	P610	PID action step	0~1.0Hz	0.1	0.5Hz
	P611	PID standby frequency	0.00~120.0Hz (0.00Hz) 0.00Hz means sleep function is closed	0.1	0.0Hz
	P612	PID standby duration	0~200s	1S	10s
	P613	PID wake up value	0~100%	1%	0
	P614	PID corresponding value of display	0~9999	1	1000
	P615	PID digit of display	1~5	1	4
	P616	PID decimal digits of display	0~4	1	2
	P617	PID upper limit frequency	0~max, frequency	0.1	48.00
	P618	PID lower limit frequency	0~max, frequency	0.1	20.00
P619	PID working mode	0: Always work(PID function open) 1: When feedback reaches upper limit (P605), it will work at Min. frequency. When feedback reaches lower limit (P606), PID will begin to work.	1	0	

Parameters		Name	Setting Range	Minimum Setting increments	Initial value
Rs485	P700	Communication speed	0:4800bps 1:9600 bps 2:19200 bps 3:38400 bps		1
	P701	Communication mode	0: 8N1 FORASC 1: 8E1 FPRASC 2: 801 FORASC 3:8N1FORRTU 4: 8E1 FOR RTU 5: 801 FOR RTU		0
	P702	Communication address	0~240	1	0
Advanced Application	P800	Advanced application parameter lock	0: Locked 1: Unlocked	1	1
	P801	System 50Hz/60Hz setting	0~50Hz 1~60Hz	1	0
	P802	Constant torque or variable torque selection	0: Constant torque 1: Variable torque	1	1
	P803	Over voltage protection setting	changing	0.1	changing
	P804	Under voltage protection setting	changing	0.1	changing
	P805	Over temperature protection setting	40~120 ° C	0.1	85/95C
	P806	Current display filter time	0~10.0	0.1	1.0 -
	P807	0~10V analogue output low end calibration coefAlient	0~9999	1	
	P808	0~10V analog output high end calibration coefAlient	0~9999	1	
	P809	0~20mA analogue output low end calibration coefAlient	0~9999	1	
	P810	0~20mA analog output high end calibration coefAlient	0~9999	1	
	P811	Reverse			
P812	UP/DOWN frequency Memory options	0: memory 1: No Memory	1	1	



Chapter 6

DESCRIPTION OF PARAMETER SETTINGS

CHAPTER 6 DESCRIPTION OF PARAMETER SETTINGS

Group P0: User Parameters

0 - 00

Main Display Data Selection

Factory setting: 00

User can set the initial display of VFD through parameter P000, For example, in order to monitor rotation speed through the operation panel, user can set parameter P000 into "03" Initial value of P000 is "00", therefore, if not been changed, inverter will display set frequency.

Parameters	Name	Value	Description
P000	Main Display Data Selection (Initial Value: 00), Setting Range (00~32)	00	
		01	Display the set frequency
		02	Display output frequency
		03	Display output current
		04	Display motor speed
		05	Display DC bus voltage
		06	Display inverter temperature
		07	Display PID
		10	Alarm Record 1
		11	Alarm Record 2
		12	Alarm Record 3
		13	Alarm Record 4
		14	Display set frequency when fault occurred
		15	Display output frequency when fault occurred
		16	Display output current when fault occurred
		17	Display output voltage when fault occurred
		18	Display DC bus voltage when fault occurred

P001 Display the set frequency

You can monitor the set frequency of inverter by examining the content of this parameter.

P002 Display the output frequency

You can monitor the present output frequency of inverter by examining the content

P003 Display the output current

You can monitor the actual output current of inverter by examining the content

P004 Display the motor speed

You can monitor the actual rotation speed of motor by examining the content

P005 Display the DC bus voltage value

You can monitor the actual voltage of DC bus of motor by examining the content

P006 Display temperature of inverter

You can monitor the actual temperature of inverter by examining parameter P006, which will help you make judgment on the running conditions of inverter

P010 Alarm record 1**P011** Alarm record 2**P012** Alarm record 3**P013** Alarm record 4

You can check the conditions of lastest four faults by examining P010 to P013. Those Four parameters can help user make judgment on the running condition of inverter and Find the cause of fault and eliminate hidden trouble





P014 Display set frequency when fault occurred**P015** Display out frequency when fault occurred**P016** Display output current when fault occurred**P017** Display output voltage when fault occurred**P018** Display Present DC bus voltage of the inverter when fault occurred

You can check the detailed status when the lastest fault occurs by examining the content

P014--P018. you can examine the frequency setting, actual output frequency, and actual output current, output voltage, DC bus voltage of main circuit, According to the above data, you can analyze the cause of fault and find a solution quickly which will help maintenance personnel in repair work

For FC100 Series, you can use parameter "F.00" to set the main display data. It's also possible to monitor the data directly through the parameters "P001~P018"

You may monitor the data by pressing switching key as shown in the below table

Procedure	Press Key	Display	Explanation
1	Turn On Power	<div style="display: flex; justify-content: space-around;"> Stop FWD </div> <div style="border: 1px solid black; padding: 5px; width: fit-content; margin: 5px auto;">F50.0</div>	1, Inverter is in standby mode. 2, The keypad displays frequency setting. FREE light is on, which means that the keypad is displaying frequency setting
2	Press 	<div style="display: flex; justify-content: space-around;"> RUN FWD </div> <div style="border: 1px solid black; padding: 5px; width: fit-content; margin: 5px auto;">F50.0</div>	Start inverter 1, Inverter is in running and RUN light is on. 2, The image displays frequency setting. Forward light is on; inverter is in Forward state.
3	Press  Once	<div style="display: flex; justify-content: space-around;"> RUN FWD </div> <div style="border: 1px solid black; padding: 5px; width: fit-content; margin: 5px auto;">H50.0</div>	Switch display; stop switching when actual output frequency is displayed. Inverter is in Forward running state. ① The actual output frequency is 50.0Hz.
4	Press  Once	<div style="display: flex; justify-content: space-around;"> Stop FWD </div> <div style="border: 1px solid black; padding: 5px; width: fit-content; margin: 5px auto;">A00.0</div>	Switch display; stop switching when actual output current is displayed. ① The actual current output is 0A
5	Press  Once	<div style="display: flex; justify-content: space-around;"> Stop FWD </div> <div style="border: 1px solid black; padding: 5px; width: fit-content; margin: 5px auto;">Frd</div>	Display running state

Group P1: Basic Parameters

P100	Digital frequency setting	Factory Setting: 0.00HZ
Setting Range: 0.00HZ- Maximum Frequency		Unit:0.011
<p>When P101 is set to 0, inverter works in Digital frequency setting mode. The frequency value is set by P100.</p> <p>During running, you can change frequency by modifying the content of parameter P100 or by pressing “▲” key or “▼” key to change frequency. If you change frequency by modifying P100, when the inverter stops running or when power is off, the modified content can be remembered.</p> <p>If you change frequency by pressing “▲” key or “▼” key, when the inverter stops running or power is off, the modified content will not be remembered; instead the original P100 will be remembered. When the inverter is started next time, it will operate at the original value of P100.</p>		

P101	Frequency Setting Selection	Factory Setting: 0
Setting Range: 0-5		Unit:1
<p>Explanation: 0: Digital frequency setting (P100)</p> <p>1: Analog voltage (0—10VDC)</p> <p>2: Analog current (0—20mADC)</p> <p>3.Setting dial (Operation panel)</p> <p>4.UP/DOWN frequency setting</p> <p>5: RS485 communication frequency setting</p>		

Frequency setting selection can be used to decide the output frequency of inverter.

0: Digital frequency setting
 The output frequency of inverter is decided by P100. Generally speaking, you can change output frequency by pressing the “▲” or “▼” key on Keypad. Refer to P100 for details.

1: Analog voltage mode (0~10VDC)
 The output frequency of inverter is decided by external voltage signal (0~10V)which is put into inverter through AVI terminal.
 There are two modes of external voltage signal: one is setting signal ranging from 0 to 10V; the other is setting by potentiometer. Refer to the following diagram for connection method.

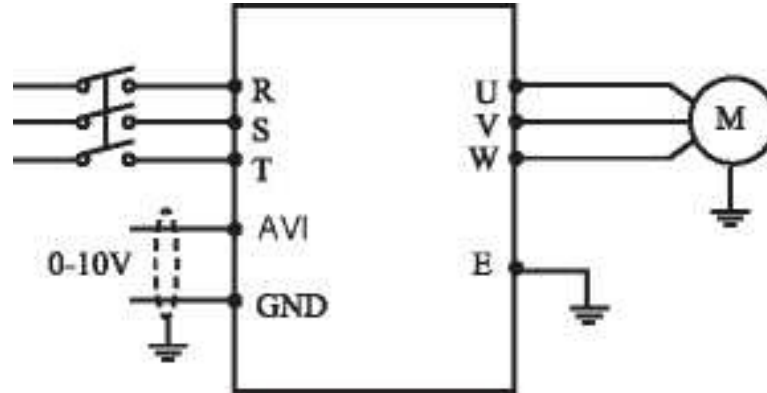

Explanation: control the output frequency through terminal AVI (0-10V).

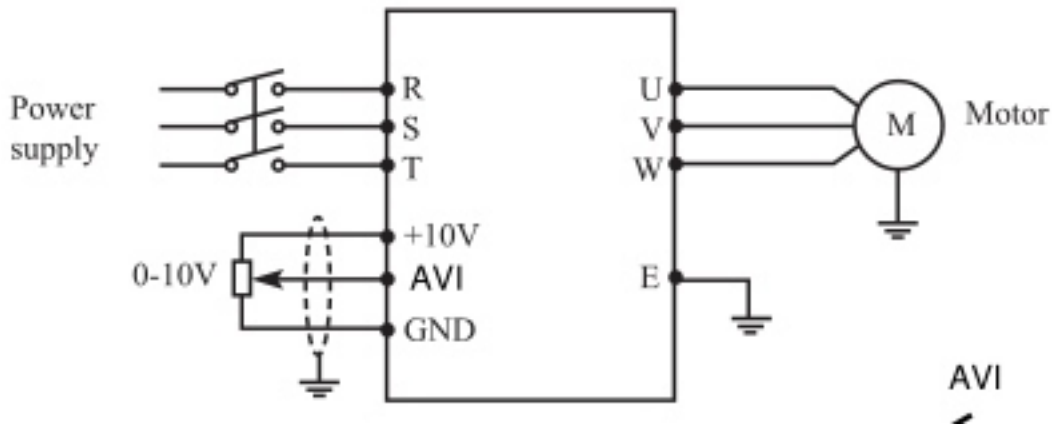

Explanation: control output frequency of inverter by AVI voltage signal sent by external POT (10k Q)

2: Analog current mode (0~20mA DC)

The output frequency of inverter is decided by external current signal (0-20mA). Control the output frequency of inverter by external terminal AVI

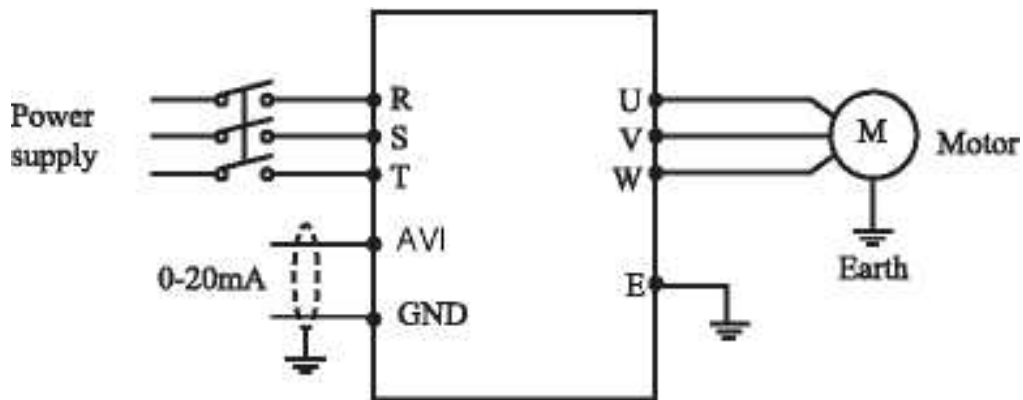

3: Setting dial mode (Operation panel)

You can control the running of FC100 series inverter by the POT knob on Keypad. Pay attention to the POT knob in Keypad which enables you to switch between monitoring images.

Turn the  change the output frequency

4 UP/DOWN setting mode

The output frequency of inverter is controlled by external UP/DOWN terminal, external terminal can be selected from P315 to P318. When UP is valid, the frequency will go up. When DOWN is valid, the frequency will go down. When UP and DOWN are both valid, the frequency will remain the same.

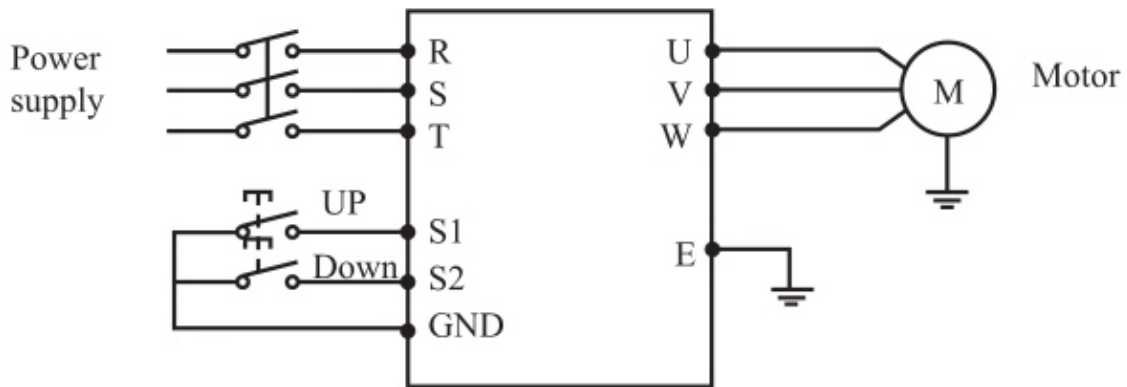

Parameter: P317=15, S1 terminal will be set in UP mode
 P318=16, S2 terminal will be set in DOWN mode.

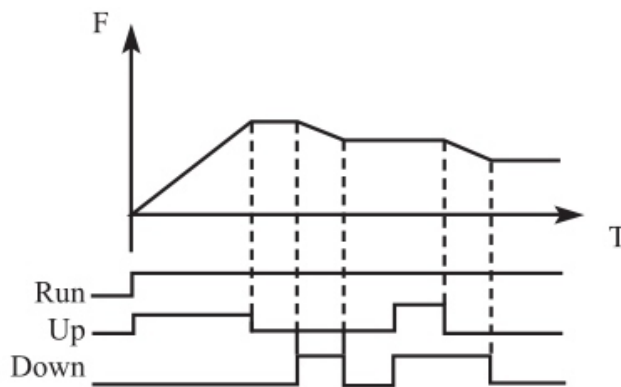

Explanation: when UP is valid (UP is closed), frequency will go up. When DOWN is valid (DOWN is closed), frequency will go down.

P102

Start signal selection

Factory Setting: 0

Setting Range: 0-2

Unit:1

Explanation: 0: Operation panel (FWD/REV/STOP)
 1: I/O terminal
 2: Communication (RS485)

Start signal selection are used to set running signal source.

0: Operation panel (FWD/REV/STOP)

Operation panel gives the running signal. The running of inverter can be controlled by the “ Run/stop ”key (Forward reverse) key on the operation panel. Press Run/stop key to stop running of inverter.

1: I/O terminal

In the initial setting ,the forward/reverse rotation signals are used as start and stop signals .Turn on either of the forward and reverse rotation signals to start the motor in the corresponding direction.

If both are turned off (or on) during operation , the inverter decelerates to a stop (or Keep the original running condition)

You can make two-wire type or three-wire type control mode by using I/O terminal

① Two-wire type

A two-wire type connection is shown below :

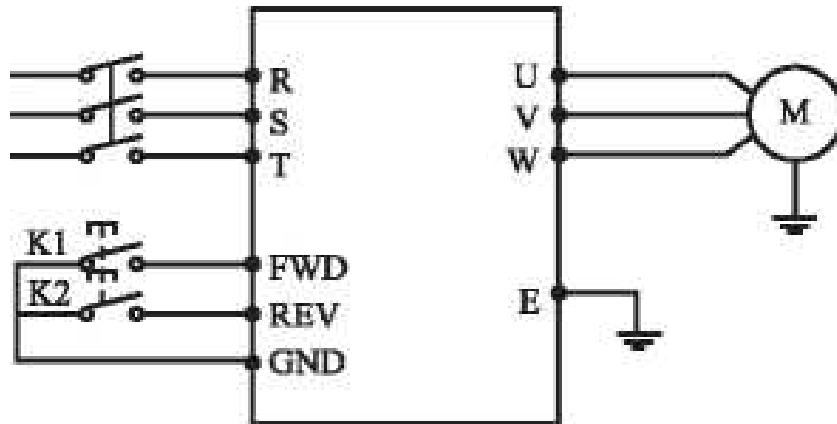

Parameter P102= 1 P315=6 P316=7

Operation Instruction of FC100 Series Inverter Actuating explanation:

6

Input Status		Status of inverter
K1	K2	
ON	OFF	Forward
OFF	OFF	Stop
OFF	ON	Reverse
ON	ON	Keep the original running condition

② Three-wire type

A three-wire type connection is shown below.

The start self-holding selection becomes valid when the STOP signal is turned on. In this case, the forward/reverse rotation signal functions only as a start signal.

If the start signal “FWD/REV” on and then off, the start signal is held and makes a start. When changing the direction of rotation, turn “FWD/REV “on once and then off.

The stop the inverter, turning off the STOP signal once decelerates it to a stop.

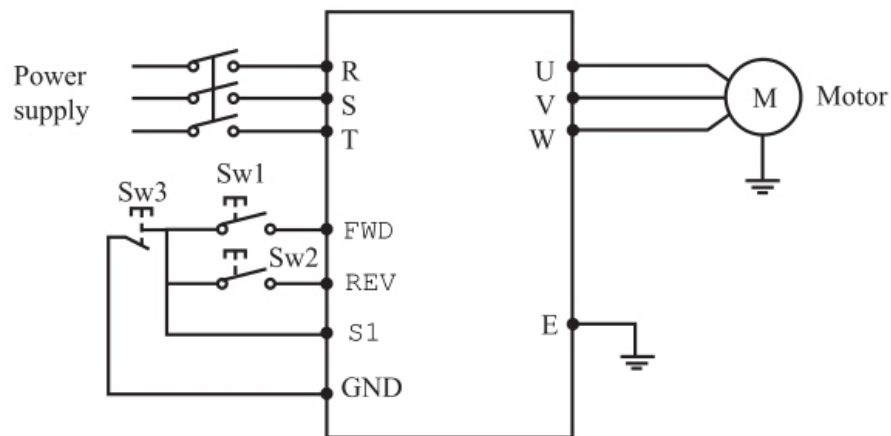

Use “FWD”, “REV” “S1” as input terminal for external signal

Parameter: P315=6 S1 is in Forwarder

P316=7 S2 is in Reverse

P317=8 S3 is in stop mode

P102=1 external terminal input

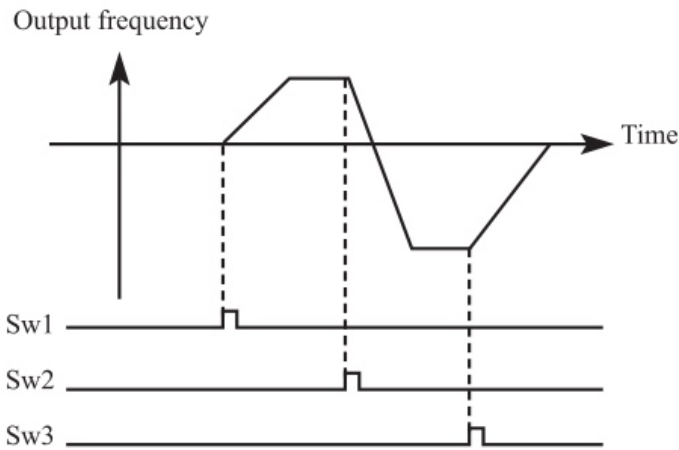

2: RS485 mode

Inverter can receive command and exchange data with computer by serial communication.

P103

“Stop” key lock operation selection

Factory Setting: 1

Setting Range: 0-1

Unit:1

Explanation: 0: “Stop”key lock mode invalid
 1: “Stop” key lock mode valid

The “STOP”key operation of the operation panel can be made invalid to prevent unexpected stop.

Set “0” in P103 , then press “ENTER” for 2s to make the “STOP” key operation invalid , and”STOP” key can not stop running of inverter Set “1” in P103 , then press “ENTER” for 2s to make the “STOP , , key operation valid , and “STOP” key can stop running of inverter

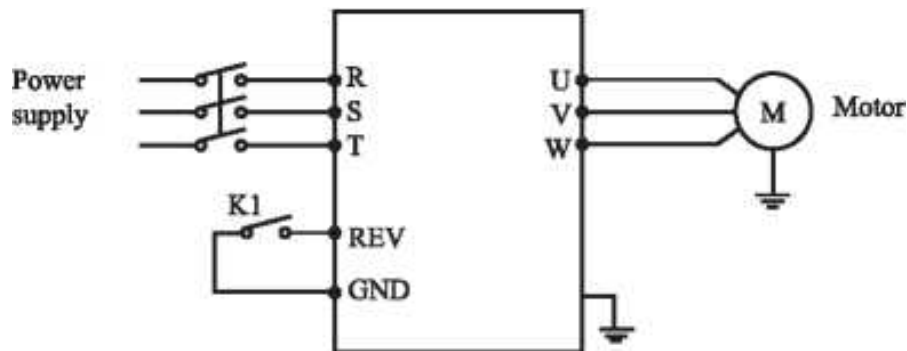

Procedure	Input	Explanation
1	K1 close	Reverse of inverter is started
2	(K1 open) press stop key	Inverter stops
3	K1 open	Running signal is removed
4	K1 close	Reverse of inverter is started

P104 Reverse prevention setting Factory Setting: 1

Setting Range: 0-1 Unit:1

Explanation: 0: Reverse prohibited
 1: Reverse allowed

Many devices only allow rotation in single direction. In this case, you can set the machine in single rotation mode by this parameter. 0: Reverse prohibited
 Reverse of motor is prohibited. When P104 is set at reverse prohibited, switch between Forward and reverse is invalid.

1: Reverse allowed
 Reverse of motor is enabled, switching between forward and reverse is valid.

P105 Max. frequency Factory Setting: 50.0HZ

Setting Range: 0-400HZ

The output frequency range of inverter is 0.1~400.00Hz. Therefore, inverter can drive the motor higher than 50/60Hz, which could cause mechanical damage or accident.

This parameter is to limit the inverter output frequency in order to prevent motor operating at too higher speed.

P106 Min. frequency Factory Setting: 0.00HZ

Setting Range: 0-400HZ

This parameter is to set the minimum output frequency of the inverter. If the setting frequency is lower than the Min. frequency, inverter will output on the Min. frequency. In some application, this function could avoid motor overheating due to the low speed operation.

P107	ACC time	Factory Setting: change
P108	DEC time	Factory Setting: change

Setting Range: 0.1s~999.9s

Acc time refers to the time for inverter to reach the max. frequency from 0.00Hz.

Dec time refers to the time for inverter to lower to 0.00Hz from max. frequency.

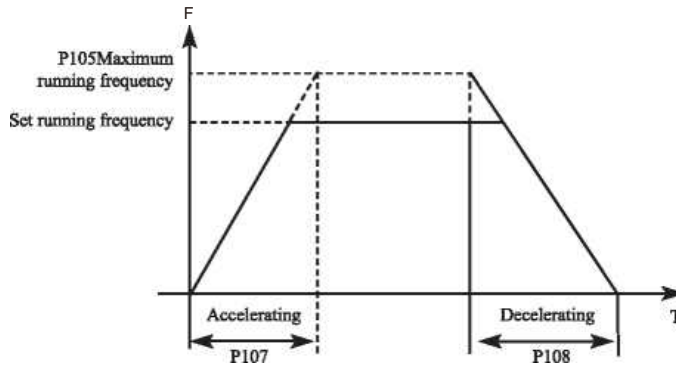

The Default Acc/Dec time is the primary Acc time/ Dec. time. Other Acc time or Dec time can be selected via external terminal.

6

P109	V/F maximum voltage	Factory Setting: 380
-------------	---------------------	----------------------

Setting Range: V/F intermediate voltage-500.00

Unit:0.1

P110	V/F fundamental frequency	Factory Setting: 50
-------------	---------------------------	---------------------

Setting Range: V/F intermediate frequency ~ max. frequency

Unit:0.1

P111	V/F intermediate voltage	Factory Setting: change
-------------	--------------------------	-------------------------

Setting Range: V/F minimum voltage ~ V/F maximum

Unit:0.1

P112	V/F intermediate frequency	Factory Setting: 2.5
-------------	----------------------------	----------------------

Setting Range: V/F minimum frequency ~ V/F fundamental

Unit:0.1

P113	V/F minimum voltage	Factory Setting: 15
-------------	---------------------	---------------------

Setting Range: 0.0 ~ V/F intermediate voltage

Unit:0.1

P114	V/F minimum frequency	Factory Setting: 1.25
-------------	-----------------------	-----------------------

Setting Range: 0.0 ~ V/F intermediate frequency

Unit:0.1

Parameters from P109 to P114 determine the V/F curve of inverter. Set corresponding V/F curves according to different loads. Constant torque curve: application for constant torque load, output voltage and output frequency are in linear relation.

Down (variable) torque curve: application for variable torque load, like fan and pump. Load will increase with the increase of rotation speed.

High start torque curve: application for heavy load and load need high starting torque.

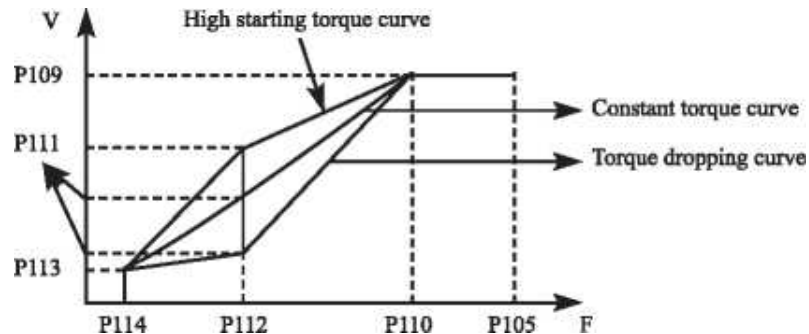

P109: V/F maximum voltage, V/F maximum voltage can be set according to the motor connected. Generally, it will be set at the rated voltage of motor. When motor is very near to inverter, usually within 30m, it should be set at a higher value.

P110: V/F fundamental frequency

V/F fundamental frequency, please set it at the running voltage frequency of motor. Generally, do not change V/F fundamental frequency setting; or else, it is very likely to damage motor.

P111: V/F intermediate voltage

Set V/F intermediate voltage according to the specific load. Improper setup can cause over current of motor or insufficient torque output, or even cause inverter protection. Increasing the value of P111 can increase output torque and output current. Please monitor output current while changing the value of P111. While changing the value of P111, adjust the value slowly until the necessary output torque is reached. Too higher setting may cause inverter protection or fault.

P112: V/F intermediate frequency

V/F intermediate frequency determines the intermediate point of V/F curve. Improper setup can cause insufficient torque or over current protection of inverter. Generally, do not change the setup value of this parameter while using.

P113: V/F minimum voltage

V/F minimum voltage setup is relevant to start torque to a certain extent. Increasing the value of this parameter properly can increase the torque of starting, it can also cause over current. Generally, it's not necessary to change the value of P113.

P114: V/F minimum frequency

V/F minimum frequency determines the initial point of V/F curve, it is the minimum value in V/F curve.

Please refer to the following table for the specific Default setting of each model:

Model	P107	P108	P111	P115
FC100-2S-0.4G	7	7	15	8
FC100-2S-0.75G	8	8	14	8
FC100-2S-1.5G	9	9	14	8
FC100-4T-0.75G	8	8	27	8
FC100-4T-1.5G	9	9	26	8
FC100-4T-2.2G	10	10	25	8

P115 Carrier frequency

Setting Range: 0-15

Unit:1

Carrier frequency decides the switching frequency of internal power module. The factory setting of inverters with different capacity are different because will affect motor noise, motor heating and disturbance.

Carrier frequency P115	Motor Noise	Motor Heating	Disturbance
Small → Big	Big → Small	Small — Big	Small — Big

Therefore, when the environment demands running without noise, you shall increase the value of P115, the maximum load of inverter will decrease. If motor is far from inverter, you shall lower the value of P115 so as to lower the leakage current between wires and wire to ground. When the environment temperature or motor load is high, you shall lower the value of P115 to reduce the heating of the inverter. Refer to table in P114 for the factory set of P115.

P117	Initialization of parameters	Factory Setting: 0
-------------	------------------------------	--------------------

Setting Range: 0-8

Unit:1

Explanation: 8: Initialization of parameters

When the parameter setup is not proper or when false running leads to improper setup of parameter, you can set P117 at 08 to restore all parameters to the Factory Setting, and then you can set them again according to actual need. Attention: when locked up of parameters is valid, that is when P118=1, you cannot carry out initialization of parameters and change them. Please unlock first, and then set these parameters.

P118	Initialization of parameters	Factory Setting: 0
-------------	------------------------------	--------------------

Setting Range: 0-1

Unit:1

Explanation: 0: unlocked

1: Locked

You can lock the parameter by P118 to prevent unexpected change of the inverter setup.

When P118 is valid, all the other parameters except P100 (main frequency setting) cannot be changed.

Group P2: Parameters of basic applications

P200	Start mode selection	Factory Setting: 0
-------------	----------------------	--------------------

Setting Range: 0-1

Unit:1

Explanation: 0: Start at start frequency

1: Tracing start

There are two start modes for FC100 series inverter. You can choose from the two by setup of parameter P200 and the condition of machinery.

0: Start at start frequency

Most loads do not have special requirement in start. Inverter output from the start frequency.

1: Tracing start

Tracing start is application for start after fault reset or instantaneous power failure. Using tracing start function, inverter can automatically detect the rotation speed and rotation direction of motor, the output the starting frequency and voltage accordingly.

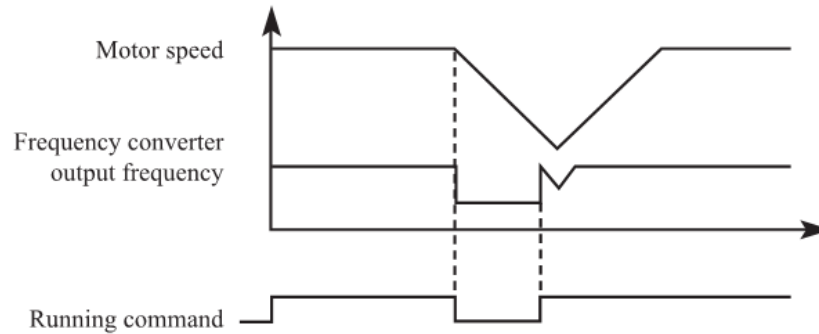

Attention: when inverter starts in tracing start mode, inverter will have speed tracing in the sequence of high to low frequency.

High current is likely in start, it is also possible to cause current. Therefore, you need to have over current level setup (P409 setup).

The specific value depends on the load

In addition, when the value of P409 is too low , it may lead to a long start time. If over current in the speed tracing, inverter will pause the speed tracing.

P201

Stop mode selection

Factory Setting: 0

Setting Range: 0-1

Unit:1

Explanation: 0: Deceleration to stop

1: Coasting stop

You can choose a suitable stop mode according to the actual load.

0: Deceleration to stop

Once inverter receives stop command, it will reduce the output frequency according to the deceleration time.

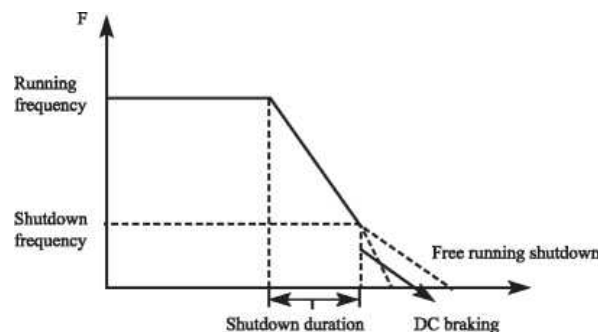

With regard to stop mode after stop frequency is reached, you can choose DC injection brake and other options. If you do not choose DC injection braking, it will stop in coasting stop mode.

1: Coasting stop

When inverter receives stop command, it will stop frequency output and it will have free running with load until it stops.

P202	Start frequency setting	Factory Setting: 0.5
-------------	--------------------------------	----------------------

Setting Range: 0.1~10.00

Unit:0.01

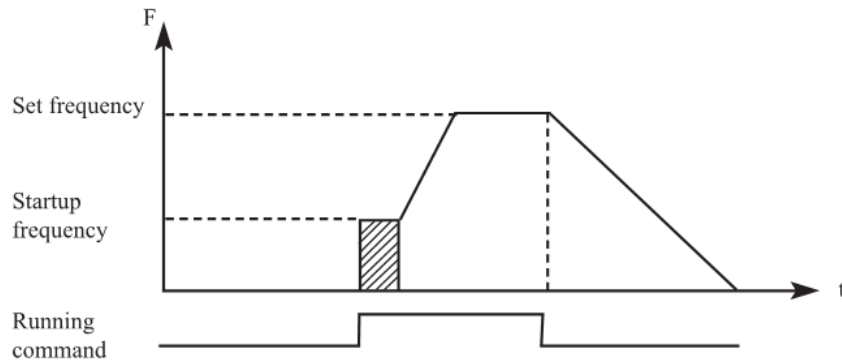

Start frequency is the initial frequency when inverter starts. For device with heavy load or requires large starting torque, increasing start frequency can make start easier. However, if the start frequency is too high, it may cause over current protection.

P203	Stop frequency setting	Factory Setting: 0.5HZ
-------------	-------------------------------	------------------------

Setting Range: 0.1~10.00

Unit:0.1

Stop frequency setting

When inverter receives stop command, it reduce the output frequency until the stop frequency, then it will start coasting stop or DC injection brake stop according to the setting.

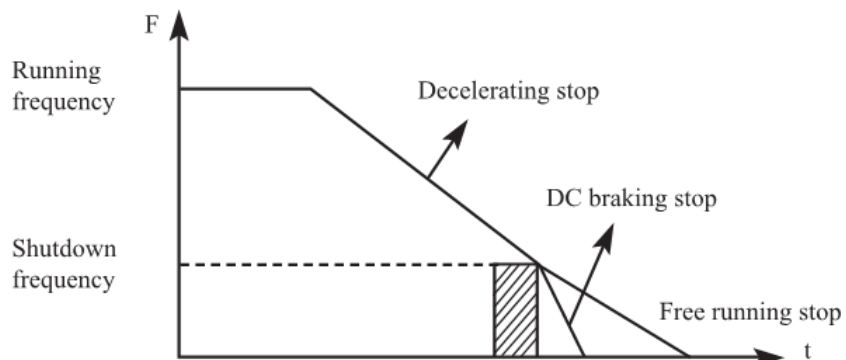

P204	Dc braking current in start	Factory Setting: 100
-------------	-----------------------------	----------------------

Setting Range: 0~150	Unit:1
----------------------	--------

P205	Dc braking time in start	Factory Setting: 0
-------------	--------------------------	--------------------

Setting Range: 0~250	Unit:1
----------------------	--------

Dc braking in start is application for fan in stop mode and moving load. Because before inverter starts, motor is in free running mode and the rotation direction is unknown. It is easy to cause over current protection in start. Therefore, before start, you shall use DC injection brake to stop the motor in advance.

Dc braking current in start is the ratio of rated current of inverter, adjusting P204 can have different braking torques. While setting value of parameter, you can adjust it from low to high until a sufficient braking torque is reached according to the actual load.

Dc braking time is the period DC injection brake lasts. When it is 0, DC injection brake is invalid.

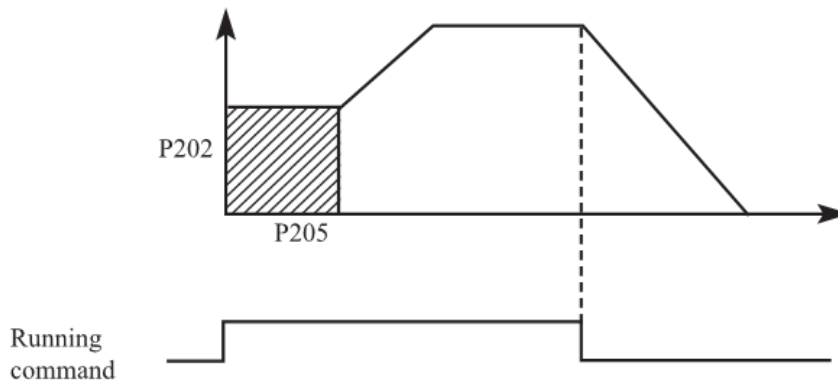

P206	Dc braking current in stop	Factory Setting: 100
-------------	----------------------------	----------------------

Setting Range: 0~150	Unit:1
----------------------	--------

P207	Dc braking time in stop	Factory Setting: 0
-------------	-------------------------	--------------------

Setting Range: 0~250	Unit:1
----------------------	--------

Dc braking in stop is application for load which has requirement on braking.

Dc braking current in stop is the ratio of rated current of inverter. Adjusting this parameter can have different braking torques.

Dc braking time in stop is the period DC injection brake mode lasts. When it is 0, DC injection brake is invalid.

Refer to the explanations of P203, P204 and P205 for relevant details.

P208	Torque boost	Factory Setting: 5%
-------------	---------------------	----------------------------

Setting Range: 0.1~20% Unit:0.1

Adjusting parameter P208 can increase voltage 3rd obtain higher torque.
 Attention: Too big setting may cause motor overheating. Increase the setting step by step until you get the requested starting torque.

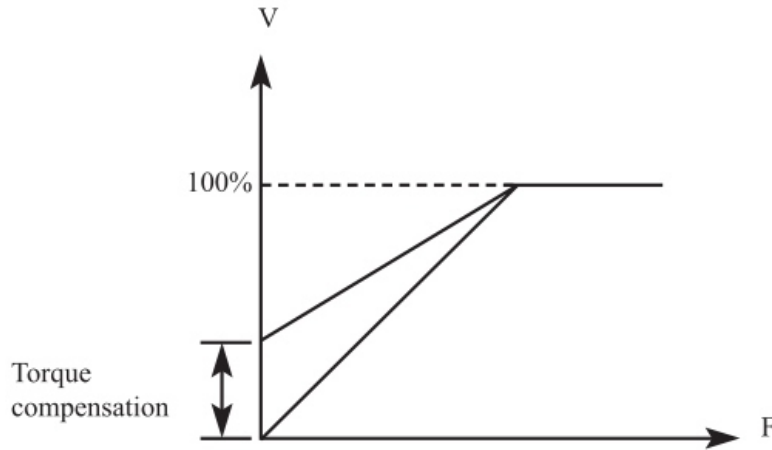

P209	Rated motor voltage	Factory Setting: 380.0V
-------------	----------------------------	--------------------------------

Setting Range: 0~380.0V Unit:0.1

P210	Rated Motor current	Factory Setting: **
-------------	----------------------------	----------------------------

Setting Range: **** Unit:0.1

P211	No load current ratio of motor	Factory Setting: 40
-------------	---------------------------------------	----------------------------

Setting Range: 0~100 Unit:1

P212	Rated motor rotation speed	Factory Setting: 1420
-------------	-----------------------------------	------------------------------

Setting Range: 0~6000 Unit:1

P213	Number of motor poles	Factory Setting: 4
-------------	------------------------------	---------------------------

Setting Range: 0~10 Unit:1

P214	Rated motor slip	Factory Setting: 2.5
-------------	-------------------------	-----------------------------

Setting Range: 0~100 Unit:0.1

Please set above parameters according to the motor rating.

P209 Rated voltage motor

Please set rated voltage of motor according to voltage value on motor nameplate.

P210 Rated motor current

Please set rated current of motor according to the current value on nameplate. If the running current exceeds the value of rated current, inverter will trip to protect the motor.

P211 No load current ratio of motor

The value of rated no load current of motor can affect slip compensation. Rated no load current is the percentage of motor current.

P212 Rated motor rotation speed

The value of parameter P112 is the rotation speed at 50Hz. It is related to rotation speed display. Generally, it shall be set according to the value on nameplate.

To display the actual rotation speed of motor, you can set parameter P212 at the actual rotation speed at 50Hz.

P213 Number of motor poles

Set the number of pole pairs of motor by adjusting this parameter according to the value on nameplate

P214 Rated motor slip

When inverter drives motor, slip will increase when load increase. Adjusting P214 can compensation the slip and make motor speed close to the synchronization speed.

P215	Rated motor frequency	Factory Setting: 50HZ
-------------	-----------------------	-----------------------

Setting Range: 0~400.0	Unit:0.1
------------------------	----------

P216	Resistance of stator	Factory Setting: 2
-------------	----------------------	--------------------

Setting Range: 0~100.0	Unit:0.1
------------------------	----------

P217	Resistance of rotor	Factory Setting: 4.5
-------------	---------------------	----------------------

Setting Range: 0~100.0	Unit:0.1
------------------------	----------

P218	Self inductance of rotor	Factory Setting: 1
	Setting Range: 0~1.0	Unit:0.1

P219	Mutual inductance of rotor	Factory Setting: 0.2
	Setting Range: 0~1.0	Unit:0.1

The above parameters are parameters of motor.
 P215 Rated frequency of motor
 Please set rated frequency of motor according to motor nameplate.
 P216 Resistance of stator
 P217 Resistance of rotor
 P218 Self inductance of rotor
 P219 Mutual inductance of rotor
 Set the above parameters according to the actual condition of motor.

Group 3: Input and Output Function Parameters

P300	AVI minimum voltage input	Factory Setting: 0
	Setting Range: 0~AVI maximum voltage	Unit:0.1

P301	AVI maximum voltage input	Factory Setting: 10
	Setting Range: AVI maximum voltage~0	Unit:0.1

P302	AVI input filter time	Factory Setting: 1.0
	Setting Range: 0~25.0	Unit:1

P300 AVI minimum voltage input
 AVI minimum voltage input value is related to frequency of lowest analogue input. Voltage command below this value is deemed as invalid command.

P301 AVI maximum voltage input
 AVI maximum voltage input value is related to frequency of highest analogue input. For voltage higher than this value, the machine will still operate at this value.
 The value of P300 and that of P301 decide the range of input voltage.

P302 Input filter time

Value of input filter time decides the response speed of inverter to analogue change. With the increase of value of P302, the inverter will get slower for responding to analogue change.

P303	AVI minimum current input	Factory Setting: 4.0
	Setting Range: 0~AVI Maximum	Unit:0.1
P304	AVI maximum current input	Factory Setting: 20.0
	Setting Range: AVI minimum~20	Unit:0.1
P305	AVI input filter time	Factory Setting: 2.5
	Setting Range:0~25.0	Unit:0.1

P303: AVI minimum current input

AVI minimum current input is related to frequency of lowest analogue input. Inverter will deem current signal below value of P303 as invalid.

P304:AVI maximum current input

AVI maximum current input is related to frequency of highest analogue input. For current command higher than value of P304, inverter will operate at the value.

P305:AVI input filter time

AVI input filter time decides how fast inverter responds to analogue change. With the increase of value of P305, inverter will respond more and more slowly to analogue change. The output of inverter will be relatively stable.

Refer to explanations of P300 to P302 for relevant parameters.

If the external input is voltage signal, refer to P300-P302. If the external input is current signal, refer to P303-P305. Current signal

For example, if the output signal of upper computer is 4-20mA, the corresponding frequency shall be within the range of 0-50Hz.

Parameters: P303=4 P304=20 P310= 0 P312=50, check as follows,

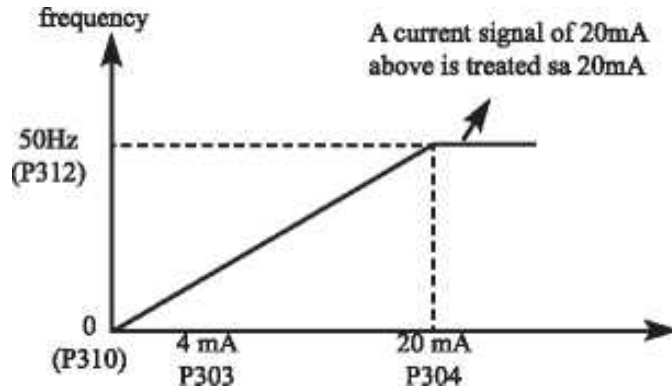

P310	Frequency of low analog	Factory Setting: 0.0
-------------	-------------------------	----------------------

Setting Range: 0~400.0 Unit:0.1

P311	Direction of of low analog	Factory Setting: 0
-------------	----------------------------	--------------------

Setting Range: 0~1 Unit:1

Explanation: 0: Positive direction
1: Negative direction

P312	Frequency of high analog	Factory Setting: 50
-------------	--------------------------	---------------------

Setting Range:0~400.0 Unit:0.1

P313	Direction of high analog	Factory Setting: 0
-------------	--------------------------	--------------------

Setting Range: 0~1 Unit:1

Explanation: 0: Positive direction
1: Negative direction

P314	Analogue reverse options	Factory Setting: 0
-------------	--------------------------	--------------------

Setting Range: 0~1 Unit:1

Explanation: 0: No reverse at negative bias voltage
1: Reverse allowed at negative bias

The parameter group of P310-P314 decides the running condition of analogue, including output frequency and direction. According to actual need of user, they can form various control curves.

P310 Frequency of low analog

Frequency of lower analogue decides the output frequency of lowest analogue input, corresponding to analogue minimum voltage (current) input.

P311 Direction of low analog

Direction of lower analogue decides the running condition at low frequency, whether it is Forward or reverse.

P312 Frequency of high analog

Analogue high-end frequency determines high-end output frequency, and is corresponding to analogue maximum voltage (current)input.

P313 Direction of high analog

Analogue high-end direction determines whether the running status of high-end frequency is forward or reverse.

P314 Analog input reverse selection

Analogue reverse selection determines running status of analog negative bias voltage, satisfied curve needed by customer can be constituted by using above

parameter.

Example 1: upper computer output 2-10 V signal to control inverter, 50Hz reverse to 50Hz forward running.

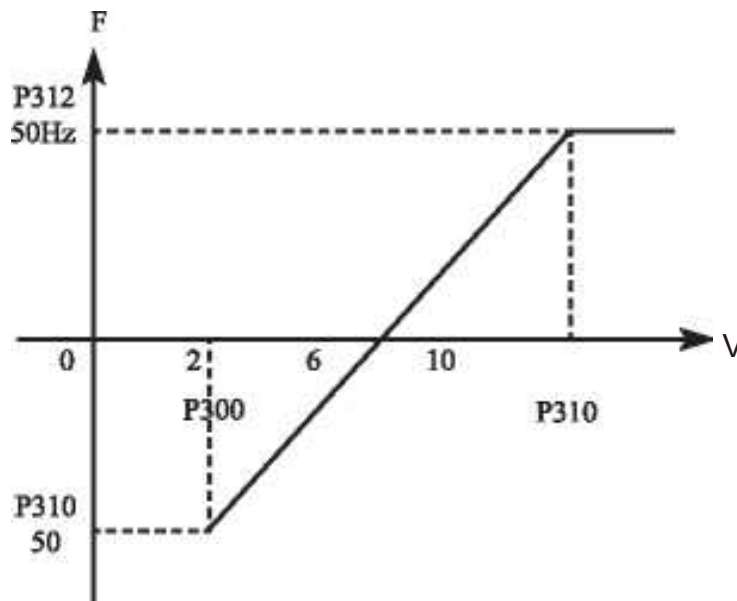

Introduction: P300=2 AVI minimum voltage input: 2V (inverter regards signals below 2V as invalid signals);
 P301=10 AVI maximum voltage input: 10V (signals over 10V are regarded and handled as 10V);
 P310=50 Analogue low-end frequency: 50Hz;
 P311=1 Analogue low-end direction: 1 (reverse);
 P312=50 Analogue high-end frequency: 50Hz;
 P313=0 Analogue high-end direction: 0 (Forward);
 P314=1 Analogue reverse selection: 1 (negative bias voltage can be reversed).
 Attention: In various curves, switching instructions of forward and reverse remain effective, when forward and reverse are switched, the curve will be reversed, and the diagram of curve is as follows:

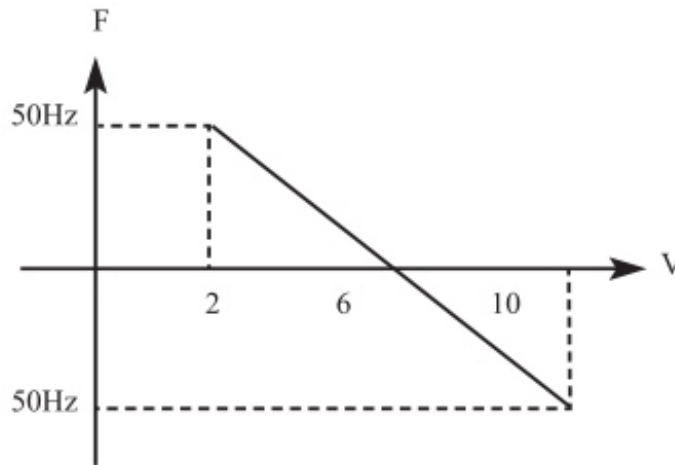

6

Example 2, upper computer output 4-20mA, and controls running of inverter
 Output frequency is 100Hz-0Hz

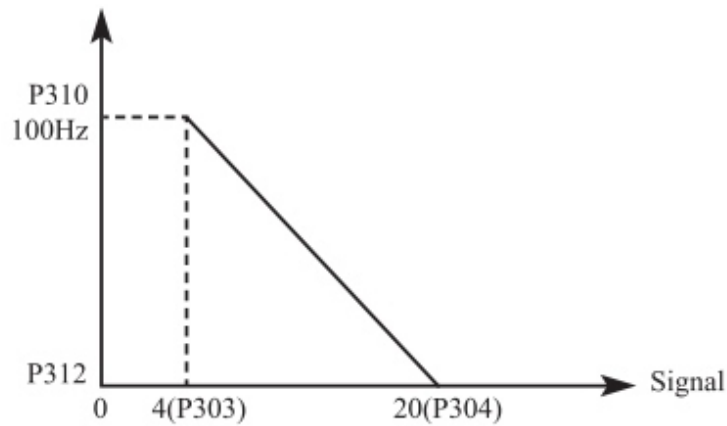

Parameter: P33=4 AVI minimum current input P304=20 AVI maximum current input P310=100.00 analogue low-end frequency P311=0 analogue low-end direction (Forward) P312=0 analogue high-end frequency P314=0 analogue high-end direction (Forward)

Special inverted curve can be constituted by using P310-P314. Introduction: signal input below 4mA is regarded as invalid signal by inverter.

P315	Multifunction input terminal — FWD terminal	Default value 6
P316	Multifunction input terminal — REV terminal	Default value 7
P317	Multifunction input terminal — S1 terminal	Default value 18
P316	Multifunction input terminal — S2 terminal	Default value 19

Setting Range:0~32

Unit:1

Setting List	<ul style="list-style-type: none"> 0: Invalid 1 : Jog 2: Jog Forward 3: Jog reverse 4: Forward/ reverse 5: Running 6: Forward 7: Reverse 8: Stop 9: Multi-speed selection 1 10: Multi-speed selection 2 11: Multi-speed selection 3 12: Multi-speed selection 4 13: Acceleration/ deceleration selection 1 14: Acceleration/ deceleration selection 2 15: Frequency increasing signal Up 16: Frequency decreasing signal Down 17: Coasting stop 18: Fault reset 19: PID function enable 20: PLC function enable 21: Timer 1 start up 22: Timer 2 start up 23: Counter pulse input 24: Counter reset 25: PLC memory clear 26: Winding operation start
--------------	---

6

0: Invalid

Set as empty terminal, no function 1 : Jog

Set as JOG (inching), usually used in trial running, common inching is operated by 5Hz,

2: Jog Forward Set as JOG forward.

3: Jog reverse Set as JOG reverse.

4: Forward/ reverse

Set as forward/ reverse switching, when the terminal is defined to be valid , running status reverse.

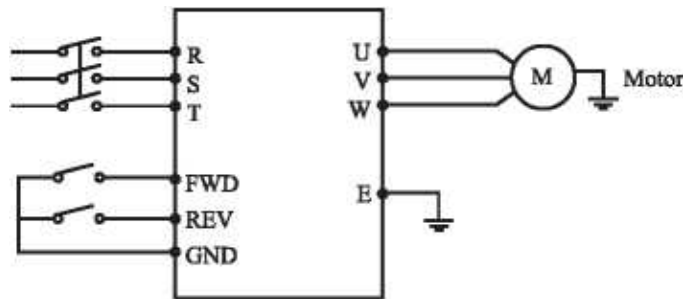

Parameter: P102=1, P315=6, P316=4

Terminal status		Running condition
FWD	REV	
ON	OFF	Forward
ON	ON	Reverse
OFF	OFF	Stop

5: Running (Set terminal as running signal.)

6: Forward (When terminal is valid, motor run forward.)

7: Reverse (When terminal is valid, motor run reverse.)

8: Stop (When terminal is valid, motor run reverse.)

9: Multi-speed 1

10: Multi-speed 2

11: Multi-speed 3

12: Multi-speed 4 (15-speed can be selected by terminal multi-speed 1,2,3 and 4 as below table:)

Multi -function terminal				Status and explanation
Multi speed 1	Multi speed 2	Multi speed 3	Multi speed 4	
0	0	0	0	Primary frequency, Primary frequency is determined by P100 or potentiometer
1	0	0	0	Multi -speed 1 (P503)
0	1	0	0	Multi -speed 2 (P504)
0	0	1	0	Multi -speed 3(P505)
0	0	0	1	Multi -speed 4 (P506)
1	1	0	0	Multi -speed 5 (P507)
1	0	1	0	Multi - speed 6 (P508)
1	0	0	1	Multispeed 7(P509)
0	1	1	0	Multi -speed 8 (P510)
0	1	0	1	Multi -speed 9 (P511)
0	0	1	1	Multi -speed 10 (P512)
1	1	1	0	Multi -speed 11 (P513)
1	1	0	1	Multi -speed 12 (P514)
1	0	1	1	Multi -speed 13 (P515)
0	1	1	1	Multi -speed 14 (P516)
1	1	1	1	Multi -speed 15 (P517)

Remark:0: terminal invalid 1: terminal invalid

13: acceleration / deceleration selection 1

14: acceleration / deceleration selection 2

4 kinds of acceleration / deceleration times can be selected by acceleration / deceleration selection terminal 1 and 2.

Multi-function terminal		Acceleration / deceleration status and result
Acceleration/ deceleration selection 1	Acceleration/ deceleration selection 2	
0	0	Acceleration/ deceleration time 1 (P107, P108)
1	0	Acceleration/ deceleration time 2 (P401, P402)
0	1	Acceleration/ deceleration time 3 (P403, P404)
1	1	Acceleration/ deceleration time 4 (P405, P406)

15. Frequency increasing signal (Up signal)

When this terminal is valid, the frequency increases at a constant speed, until operative frequency is highest.

16. Frequency decreasing signal (Down signal)

When this terminal is valid, the frequency decreases at a constant speed, until operative frequency is lowest.

Attention: Inverter will not memorize the frequency setting changed by “UP” and “DOWN” signal. When power is turned off and reset again, inverter still memorizes the set value in P100.

17: Coasting stop

When this terminal is valid, inverter coasting to stop.

18. Fault reset

Reset the inverter when alarm occurs, this terminal function is same to that of the RESET key on the Keypad.

19. PID function enable

When this contact closes, PID function is enabled. When P601 is set as 2, PID is invalid when this contact is disconnected.

20. PLC function enable

When this contact closes, PLC function starts up, and corresponding PLC function opens.

21. Timer 1 starts up

22. Timer 2 starts up

When this contact closes, timer starts up and begins timing, when the timer reaches set value, corresponding multifunction output contacting action.

23. Counter pulse input

This terminal may accept pulse signals of no more than 250 Hz.

24. Counter resetting

The counted values may be reset and cleared through this terminal.

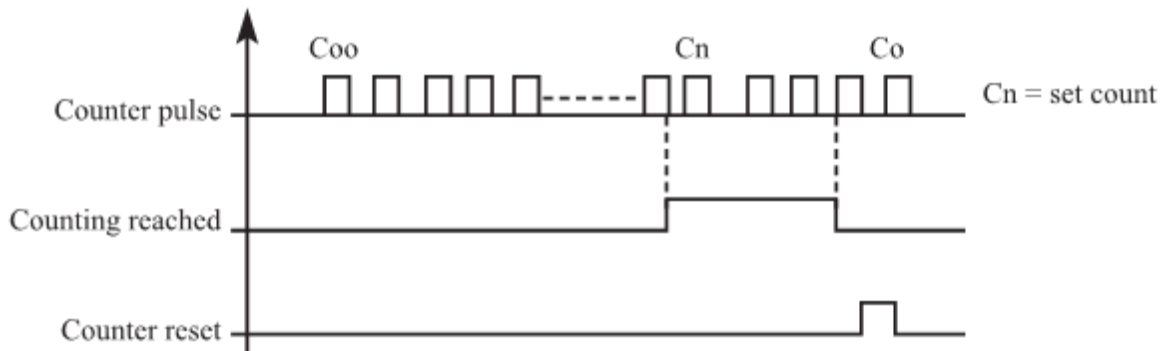

19. PLC memory removal

In the running process of PLC program, owing to fault or stopping, inverter will record status of the program automatically, after the fault is cured and the inverter is switched on again, the inverter will continue running according to the program, when memory removal is valid, program may be reset, and inverter operates from the beginning.

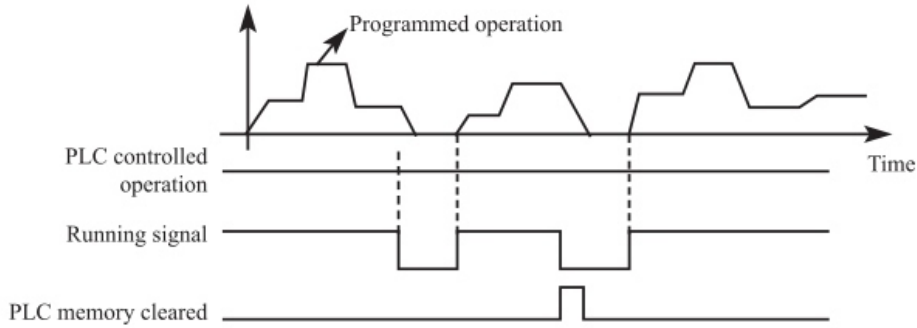

26. Winding function enable

When this signal is valid, winding function is enabled.

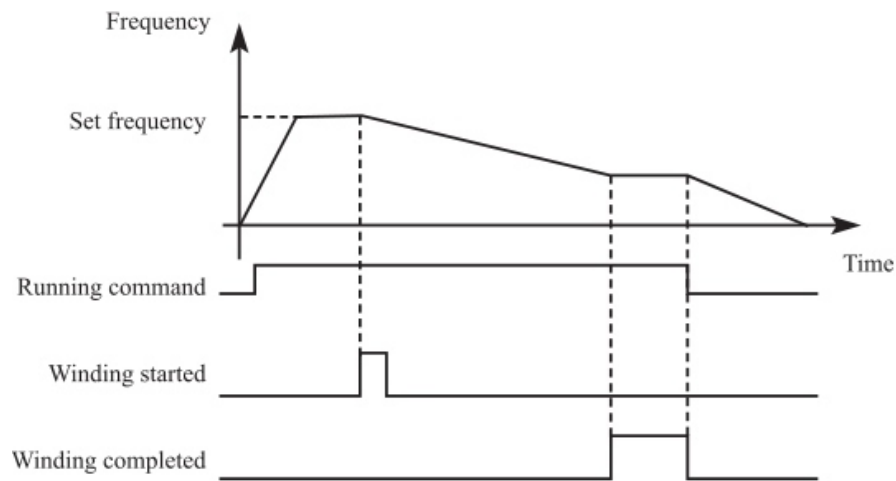

Introduction:

- 1, Winding function is activated, and winding begins;
- 2, Winding operation complete, inverter output according to the frequency that winding is completed. The multifunction terminal output the winding complete signal;
- 3, Inverter stops, the winding complete signal reset.

P325

Output terminal - RA/RC

Default value 03

Setting Range:0~32

Unit:1

Setting List	<p>0: Invalid</p> <p>1: In running</p> <p>2: Frequency reached</p> <p>3: In fault</p> <p>4: Zero-speed</p> <p>5: Frequency 1 reached</p> <p>6: Frequency 2 reached</p> <p>7: Accelerating</p> <p>8: Decelerating</p> <p>9: Under voltage</p> <p>10: Timer 1 reached</p> <p>11: Timer 2 reached</p> <p>12: Indication for completion of phase</p> <p>13: Indication for completion of procedure</p> <p>14: PID upper limit</p> <p>15: PID lower limit</p> <p>16: 4-20mA cable open</p> <p>17: Overload</p> <p>18: Over torque</p> <p>26: Winding function complete</p> <p>27: Counter reached</p> <p>28: Intermediate counter reached</p> <p>29,constant pressure water supply</p>
-----------------	---

0: Invalid

Set as invalid terminal, prevent false operation.

1.In running

Terminal is defined to be in running, when inverter is output, this terminal is ON.

2.Frequency reached

When frequency arrives at setting value, this contact is ON

3.In fault

When inverter detects abnormal existing, this contact is ON.

4.Zero-speed

When frequency output by inverter is less than start-up frequency, this contact is ON.

5.Frequency 1 reached

6.frequency 2 reached

When frequency arrives at setting value, this contact is ON

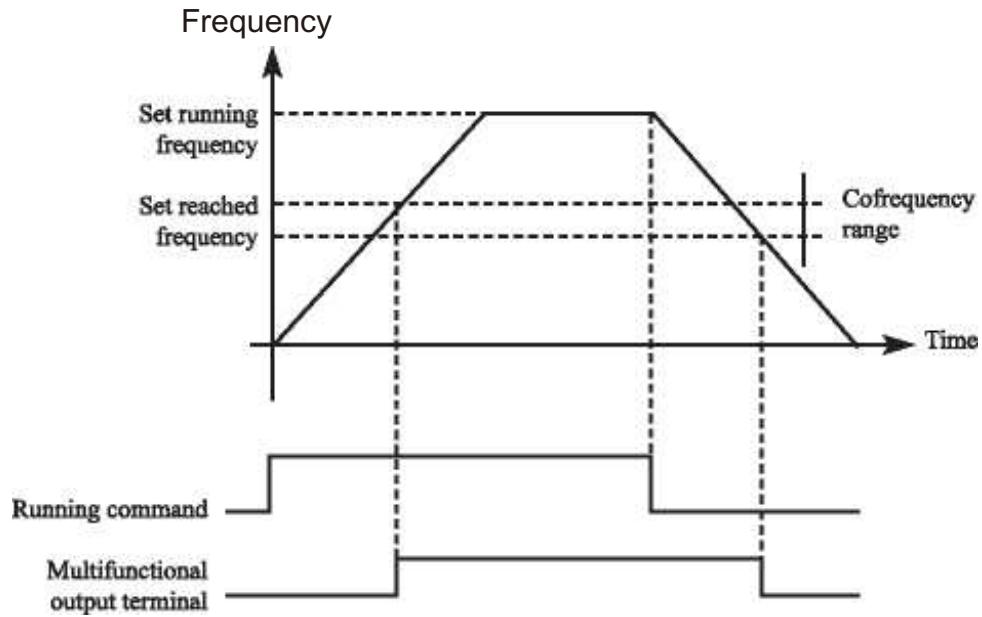

7: Accelerating

When inverter is in the status of accelerating, this contact is ON.

8: Decelerating

When inverter is in the status of decelerating, this contact is ON.

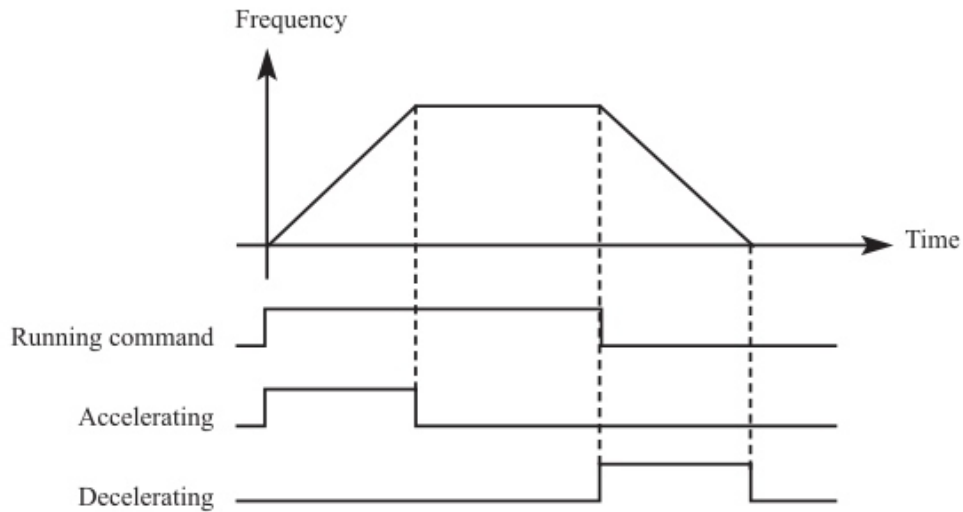

9. Under voltage alarming

When inverter detects that DC bus voltage is lower than setting value, this contact is ON and alarm. Under voltage alarming setting value can be changed through advanced application parameter group.

10: Timer 1 reached 11: Timer 2 reached

When inverter arrives at setting value, this contact is ON, when timer start-up signal is removed, this contact is reset.

12: Stage completion indication

In the PLC operation mode, inverter output this pulse signal when inverter finished a section of program.

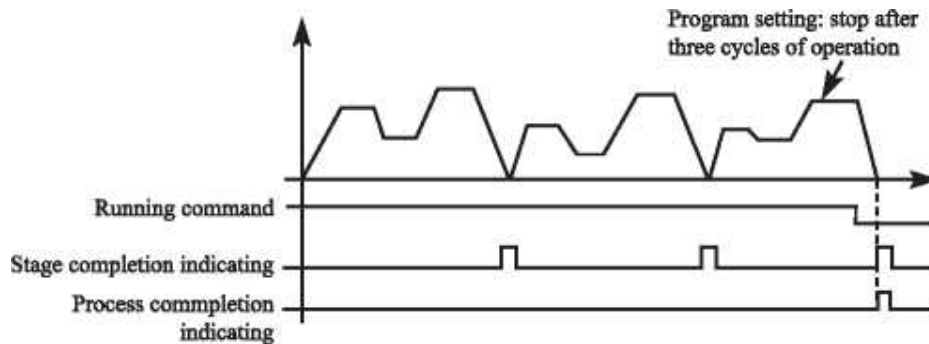

13. Process completion indication

In the PLC operation mode, inverter output this pulse signal when inverter finished the entire program.

14. PID upper limit

When PID feedback quantity exceeds setting value of upper limit, this contact is ON.

15: PID lower limit

When PID feedback quantity is lower than setting value, this contact is ON.

16: 4-20mA cable open

When FIC input signal is disconnected, this contact is ON and alarms.

17: Overload detection

When inverter detects that motor overloads, this contact is ON.

18: Over torque detection

When inverter detects over torque, this contact is ON.

26: Winding function complete When winding function is complete, this contact is ON. When inverter stops, this contact is reset.

27: Set counter reached

When inverter implements external counter, and when count value arrives at setting value (P425), this contact is ON.

28: Middle counter reached

When inverter counts, if count value arrives at setting value (P426), this contact is ON.

29: constant pressure water supply (P325 is set to 29, RA and RC close (1) indicate that the function of constant pressure water supply is effective. RA, RC disconnection (0) indicates that the function of constant pressure water supply is invalid.)

Group P4: Secondary Application Group

P400	Jog frequency setting	Default value 5.0
	Setting Range:0~Max Frequency	Unit:0.1
	Jog frequency setting is usually applied to trial run. This function can only be through external terminal.	
	When JOG function is achieved, other instruction is invalid. When JOG signal is open, inverter decelerate to stop, JOG acceleration/ deceleration time is set in the 4th acceleration/ deceleration parameter.	
	Control priority level: Jog-External Multi Speed - PLC Operation Means-PID Means - Raingle Wave(traverse function) - Winding - Frequency Conversion Setting Means	
P401	Acceleration Time 2	Default value10
P402	Acceleration Time 2	Default value10
P403	Acceleration Time 3	Default value20
P404	Acceleration Time 3	Default value20
P405	Acceleration Time 4	Default value2.0
P406	Acceleration Time 4	Default value2.0
	Setting Range:0~999.9S	Unit:0.1
	FC100 series inverters can set 4 acceleration / deceleration time. For normal operation, the default selection is the acceleration / deceleration time 1. For JOG operation, the default selection is acceleration / deceleration time 4.	
P407	Setting value of counter	Default value100
P408	Middle value of counter	Default value 50
	Setting Range:0~999.9S	Unit.1
	Fc100 Series inverter design 2 group of counters, pulase signal less than 250Hz can be accepted through multi-function terminal, when exeunt value reaches setting value, corresponding multifunction output terminal is ON, input terminal of counter resets signal through counter, counter resets and begins counting again.	
P409	Acceleration torque limiting level	Default value 150
	Setting Range:0~200	Unit.1

Parameter P409 is the torque limit level during acceleration. When output current reaches the setting value, inverter will stop accelerating, and when current is below the set value, inverter resume the accelerating.

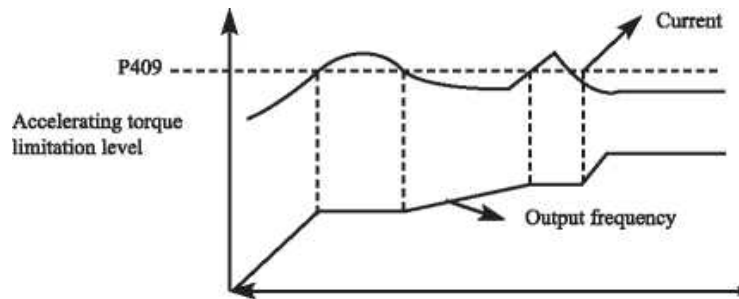

100% current is the rated current of inverter, when P409 is set to be 0, then accelerating torque limit is invalid, and it does not have protecting function.

P410	Constant-speed torque limiting level	Default value 00
-------------	---	------------------

Setting Range:0~200

Unit:1

Parameter P409 is the torque limit level during constant speed. When output current reaches the setting value, inverter automatically reduce the output frequency in order to reduce the load. When the output current drops, inverter increase output frequency to the setting (100% current is rated current of inverter).

When P410 is set to be 0, constant-speed torque limiting level is invalid and cannot protect.

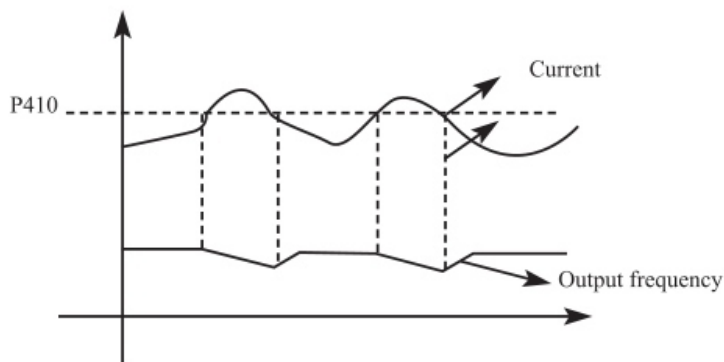

P410	Deceleration over-voltage prevention selection	Default value 1
-------------	---	-----------------

Setting Range:0~1

Unit:1

P413 Automatic energy-saving selection Default value 0.0

Setting Range:0~100 Unit:1

P413 Automatic energy-saving selection

In constant-speed running of automatic energy-saving selection, best voltage value may be calculated by loading condition and provided to load, in order to achieve best energy-saving.

Attention: for running that load changes frequently or is almost at full load, this function is not suitable.

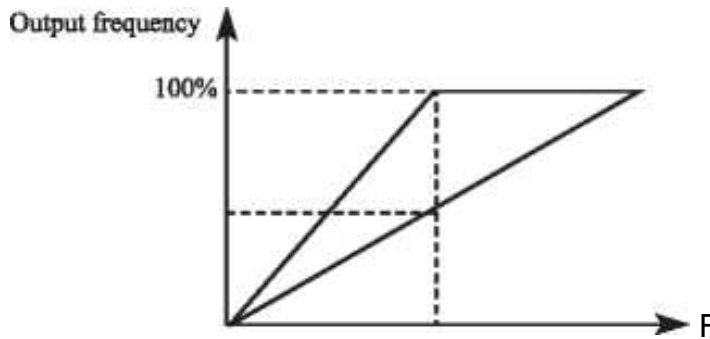

P416 Restart after instant power off Default value 0.0

Setting Range:0~1 Unit:1

Explanation: 0: Invalid: no restart after instant power failure
 1: Valid: frequency tracing start-up

0: Invalid

Inverter clears the running command after power failure. After power is recovered, inverter will not start automatically.

1: Frequency tracing enable

When power is shut-off in short time, inverter keeps the running command as effective. When power is recovered in time, inverter will tracing the motor speed and resume output.

Attention: when instant power failure restarting is enabled, inverter may start the motor automatically. Please take care of the safety when use this function.

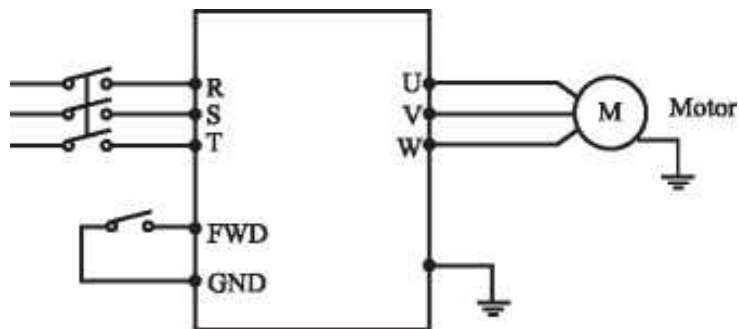

Example:

Use K1 (FWD), control running of inverter.

K1 closes, frequency conversion operates, when K1 is cut off, inverter stops.

When power is shut off and K1 remains closed, if power is on, inverter starts up suddenly and it may be very dangerous. Please use other control methods, such as three-wire system connection method.

P417	Allowable time of power off	Default value 5.0
	Setting Range:0~10.00	Unit:0.1
	P417 sets allowable time of power failure, if time of power failure exceeds set value, power failure restart is invalid.	

P418	Flank restart current limiting level	Default value 150
	Setting Range:0~200	Unit:0.1
	When inverter implements flying restart, inverter tracing downwards from setting frequency by highest speed, output current of inverter increases relatively rapid and may exceeds protection unit setting by inverter, at this time, inverter stops tracing, and output current of inverter falls back to common, inverter continues tracing, setting value 100% of this parameter is rated current of inverter, and protection unit when inverter searching may be set through P418.	

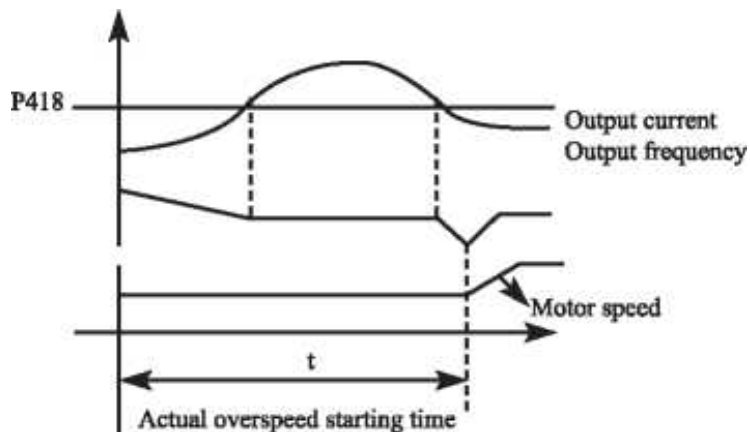

P419	Flank restart time	Default value 5
	Setting Range:0~10	Unit:1
	When inverter enabled the flying restart function, inverter tracing motor speed downwards within the setting time. If it is not completed within setting time, inverter protects.	
	In above example, when t value > P419 setting value, inverter protects	

6

P420	Fault restart times	Default value 0
	Setting Range:0~5	Unit:1
P421	Delay time for restart after fault	Default value 150
	Setting Range:0~100	Unit:1
	<p>After alarm (such as current, over-voltage and so on) occurs, inverter resets automatically (valid when non-zero as set by P420) , after the period of time set by P421, inverter starts up according to setting start-up means (P200). After start-up, if no alarm happens within 60 seconds, inverter resets P420 automatically, after start-up, If alarm happens again within 60 seconds, inverter records number of alarms, and when number of alarms reaches set value of P420, inverter stops output. Attention: If P420=0, fault restart is invalid. When fault restart function is valid, motor may start suddenly, so when this function is used, please pay attention to safety.</p>	
P422	Over torque action	Default value 0
	Setting Range:0~3	Unit:1
	<p>0: Inverter start detecting over torque only in constant speed, inverter continues operation during over torque 1: Inverter start detecting over torque only in constant speed, inverter stop during over torque 2: Inverter always detecting over torque, inverter continues operation during over torque 3: Inverter always detecting over torque, inverter stop during over torque</p>	
P423	Over torque detection level	Default value 0
	Setting Range:0~200%	Unit:1
P424	Over torque detection time	Default value 0
	Setting Range:0~200S	Unit:1
	<p>When output current of inverter exceeds setting value of P423, inverter start calculate the over torque time. When the duration exceeds half of setting value of P424, inverter output pre-alarm signal. Inverter continues output until the over torque time exceeds P424 setting, and then inverter protects and output alarm signal. If P423=0. over torque detection is invalid, and 100% is inverter rated current.</p>	

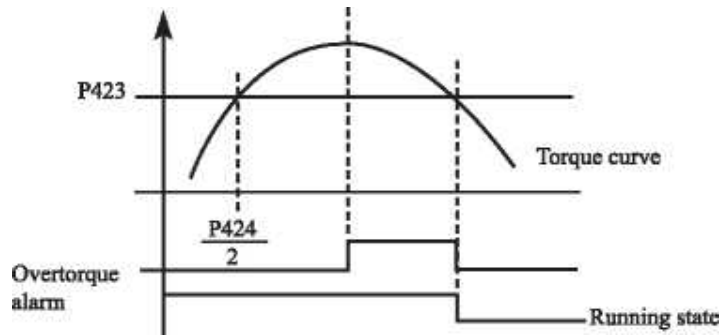

P425	Reaching frequency 1	Default value 100
	Setting Range:0~Max frequency	Unit:0.1
P426	Reaching frequency 2	Default value 5.0
	Setting Range:0~Max frequency	Unit:0.1

FC100 Series set two groups of frequencies arrive,when output frequency arrive the setting value of P425 and P426,corresponding multi-function output terminal is ON. Frequency arrive width is of a hysteresis loop,which is set by P430

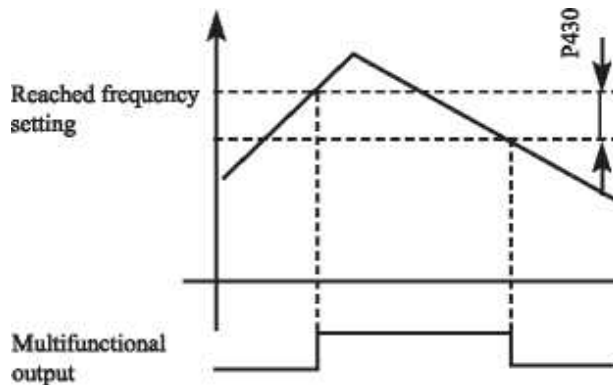

P427	No. 1 timer	Default value 0
	Setting Range:0~10.0S	Unit:0.1
P428	No. 2 timer	Default value 0
	Setting Range:0~100S	Unit:1

FC100 series have two timers, when time of the timers reaches setting value (set by P427 and P428), corresponding multi-function terminal is ON.

Timer start is controlled by external multi-function input terminal. Some simple program may be made by using these two timers.

P429	Constant-speed torque limiting time	Default value 0.5
	Setting Range:0~999.9S	Unit:0.1
P430	Width of arrive of frequency in hysteresis loop	Default value 0.5
	Setting Range:0~2.00S	Unit:0.1
	This parameter sets frequency reached width, for details, refer to P425-F426 introductions	
P431	Jump Frequency 1	Default value 0
	Setting Range:0~frequency upper limit	Unit:0.1
P432	Jump Frequency 2	Default value 0
	Setting Range:0~frequency upper limit	Unit:0.1
P433	Jump frequency hysteresis loop width	Default value 0.5
	Setting Range:0~2.0	Unit:0.1
	If machine resonance occurred at a certain frequency, we can use the frequency jump function to skip the resonance point. It support 2 jump frequencies by parameter P431 and P432.	

Frequency jump hysteresis loop width can be set through P433 as below:

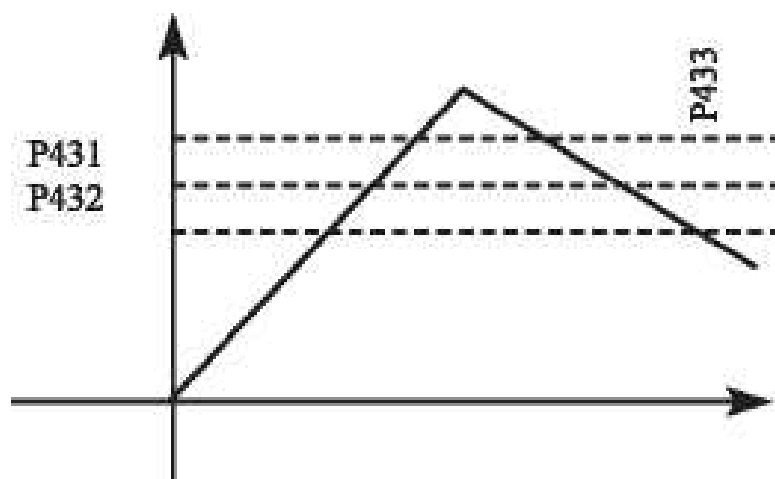

Group P5: PLC Control(Special Operation)

P500	PLC memory mode	Default value 0
-------------	-----------------	-----------------

Setting Range:0~1 Unit:1

Explanation: 0: Do not remember 1: Remember

0: Do not remember

In the operational process of PLC program, P500 will choose not to remember. When machinery stops because of fault or other reasons, inverter will not remember status before the stopping. After restart, running begins from initial state.

1: Remember

In the running of PLC program, P500 will select to remember. When it stops because of fault or other reasons, inverter will remember status before stopping. After restart, inverter will continue operating according to program.

Attention: power cannot be cut off.

Stop,power cut and power on, inverter will not remember status before power cut off. After restarting, inverter will run according to initial state of program.

P501	PLC start mode	Default value 0
-------------	----------------	-----------------

Setting Range:0~1 Unit:1

Explanation: 0: Invalid (PLC can not start) 1: Valid (PLC start)

P501 determines PLC start mode of inverter.

P501=0, means PLC is invalid. The inverter is operated by common mode.

When P501=1, PLC will start. The inverter select PLC program to run.

Under the status of PLC start, when various running orders and programs, inverter will choose the highest level to run according to priority level.

Precedence level	Priority level	Item
High – low	1	Jog
	2	External multi -speed
	3	Internal multi -speed
	4	PID
	5	Triangular wave
	6	Winding
	7	Inverter setting mode

P502 PLC running mode Default value 0

Setting Range:0~4

Unit:1

Explanation:

- 0: PLC stop running after a week
- 1: PLC pause mode, stop running after a week
- 2: PLC cycle running
- 3: Cycle running of PLC pause mode
- 4: After running for a week, PLC continues running by the end of running frequency

PLC running mode determines running status of internal multispeed, either running one circle or cycle running. P502 is only valid when PLC starts up. PLC pause mode means that when completing every speed in the running process of internal multi-speed, the speed will be down, stop, and accelerate to the next speed. The illustration is as below:

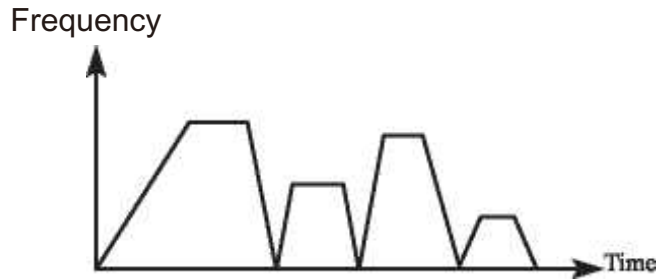

Users may select proper running mode according to actual conditions.

P503	Multi-speed 1	Default value 10.0
P504	Multi-speed 2	Default value 15.0
P505	Multi-speed 3	Default value 20 .0
P506	Multi-speed 4	Default value 25.0
P507	Multi-speed 5	Default value 30.0
P508	Multi-speed 6	Default value 35.0
P509	Multi-speed 7	Default value 40.0
P510	Multi-speed 8	Default value 45.0
P511	Multi-speed 9	Default value 50.0
P512	Multi-speed 10	Default value 10.0
P513	Multi-speed 11	Default value 10.0
P514	Multi-speed 12	Default value 10.0
P515	Multi-speed 13	Default value 10.0
P516	Multi-speed 14	Default value 10.0
P517	Multi-speed 15	Default value 10.0

Setting Range:0~Max Frequency

Unit:0.1

P503 — P517 are set of 15 speed of rated frequency in the running. Regarding relationship multi speed and external terminal please refer to rated instruction 1,2,3,4 of multifunctional terminal.

P518	PLC operation time 1	Default value 100
P519	PLC operation time 2	Default value 100
P520	PLC operation time 3	Default value 100
P521	PLC operation time 4	Default value 100
P522	PLC operation time 5	Default value 100
P523	PLC operation time 6	Default value 0
P524	PLC operation time 7	Default value 0
P525	PLC operation time 8	Default value 0
P526	PLC operation time 9	Default value 0
P527	PLC operation time 10	Default value 0
P528	PLC operation time 11	Default value 0
P529	PLC operation time 12	Default value 0
P530	PLC operation time 13	Default value 0
P531	PLC operation time 14	Default value 0
P532	PLC operation time 15	Default value 0

Setting Range:0~999.9S

Unit:1

PLC operation time determines internal controlling varying rated running duration for each segment, and the running duration for each segment is corresponding to its rate.

P533	PLC operation time 15	Default value 0
-------------	-----------------------	-----------------

Setting Range:0~9999

Unit:1

P533 setting running direction of each segment Method of setting running direction:

The way of setting running direction: by means of 16-bit binary system, and then transfer to decimal system value; every bit decides the corresponding running direction: 0 is running forward and 1 is running backward, and this parameter is only valid when the PLC is on.

For example: there is a five-segment rate, the circling running is required as follow:

Items	Output frequency	Running direction	Running duration
Dominant frequency	Potentiometer is adjustable	Forward	
Segment 1	20.0	Reverse	20
Segment 2	60.0	Forward	25
Segment 3	40.0	Reverse	30
Segment 4	15.0	Forward	20

Two buttons, one is for running, the other one is for ceasing; the main frequency requires adjustable potentiometer.

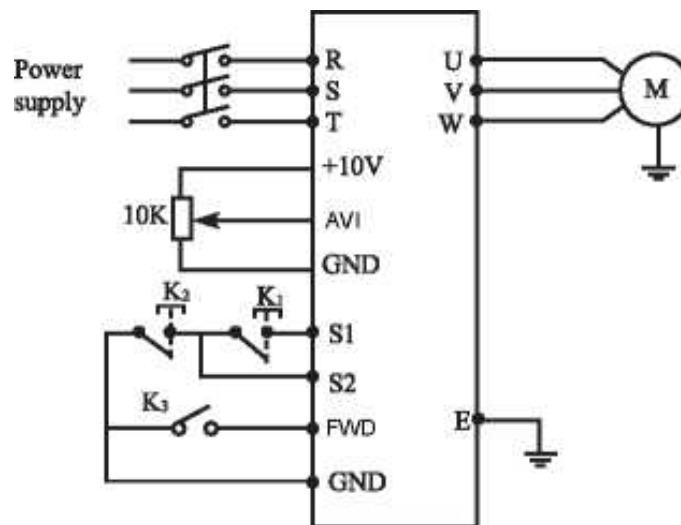

(1) Connection illustration

(2) PLC operation direction setting: (P533 setting)

Rate of segment 1	Rate of segment 2	Rate of segment 3	Rate of segment 4	Dominant frequency	
4	3	2	1	0	→ position (bit)
0	1	0	1	0	→ run direction <0 is forward, 1 is Reverse
0x24	1x23	0x22	1x21	0x20	→ transfer to decimal system

The binary system number 01010 is transferred to decimal system number: $1 \times 2^1 + 1 \times 2^3 + 8 = 10$

Define to: P533=10

The parameter defines to:

- P101=3 Keyboard potentiometer setting mode: dominant frequency is controlled by potentiometer
- P 102=2 Running setting option: Multifunction end input
- P105=60 The max. frequency is 60HZ
- P107= 10 P108=10 (acceleration/deceleration time 10S)
- P314=6 S1 end is running forward
- P318=8 S2 end is ceasing
- P315=20 FWD end is PLC starting to running
- P500=1 programming memory
- P501=1 PLC is on
- P502=0 PLC operation one circle and then ceasing
- P503=1 Segment 1 rated 20Hz
- P504=60 Segment 1 rated 60Hz
- P505=40 Segment 1 rated 40Hz
- P506=15 Segment 1 rated 15Hz
- P518=10 Segment 1 rated running duration is 10s
- P519=20 Segment 1 rated running duration is 25s
- P520=25 Segment 1 rated running duration is 30s
- P521=30 Segment 1 rated running duration is 30s

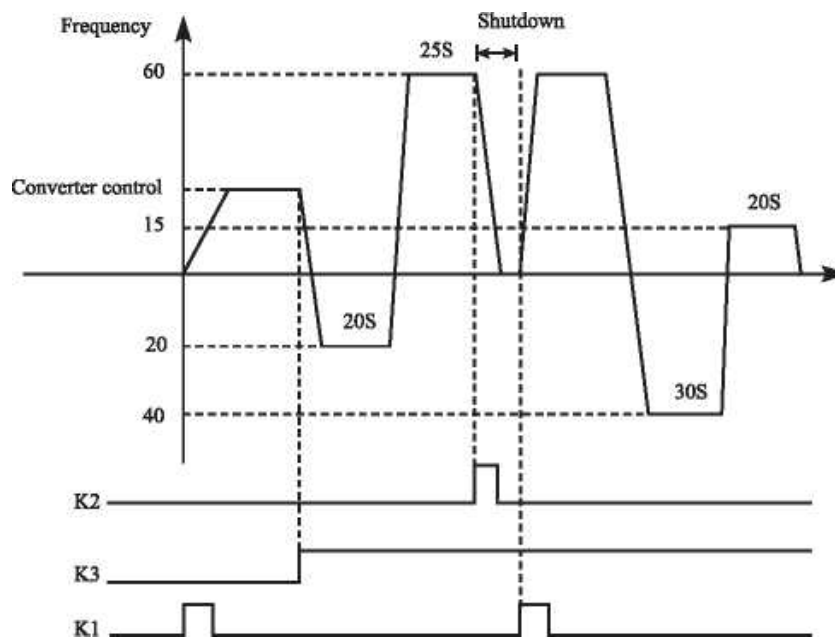

Action instruction:

- 1, Press K1 to startup the inverter and the potentiometer will set output frequency.
- 2, Press K3, PLC to startup, and from the segment 1 PLC program running one circle and then ceasing
- 3, If the program is running, press K3, or if there is a fault, and the inverter is ceasing, when the fault is solved, press K1 and the inverter will running forward as the program.
- 4, If P500 is 1 and the program is not memory, so the running will start from the very beginning.

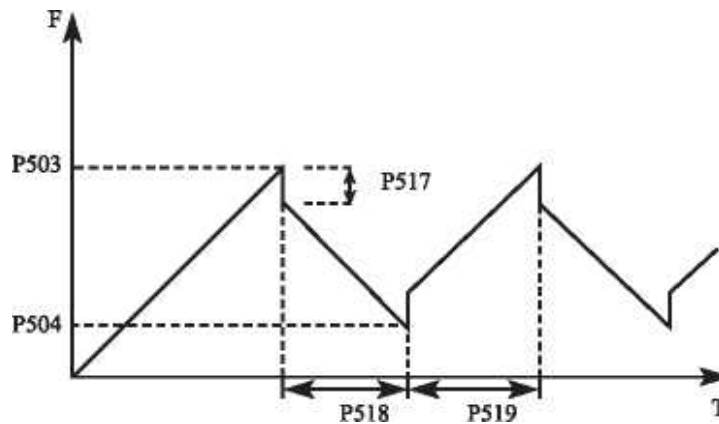

Group P6: PLC Control(Special Operation)

The inverter can be used to exercise process control, e.g. flow rate, air volume or pressure.

The terminal AV/AI input signal or parameter setting is used as a set point and the terminal AV/AI input signal also can be used as a feedback value to constitute a feedback system for PID control.

P600	PID starting mode	Default value 0
-------------	-------------------	-----------------

	Setting Range:0~1	Unit:1
--	-------------------	--------

Explanation:0: PID disable PID can not use.

1: PID start(PID is working despite the external signal input, and keeps being valid without external input.)

2: PID starts up on condition; (PID will start when certain external input is ON.)

P601	PID operation mode selection	Default value 0
Setting Range:0~1		Unit:1
<p>Explanation: 0: Negative feedback mode 1: Positive feedback mode</p> <p>Explanation: 0: Negative feedback mode If feedback value(P603)>setting value(P602), inverter decrease output frequency If feedback value(P603)<setting value(P602), inverter increase output frequency 1: Positive feedback mode If feedback value(P603)>setting value(P602), inverter decrease output frequency If feedback value(P603)<setting value(P602), inverter increase output frequency</p>		
P602	PID action set point	Default value 0
Setting Range:0~2		Unit:1
<p>Explanation: 0: figure mode (P604) 1: AVI(0-10V) 2: AVI(0-20mA)</p> <p>0: Select figure mode as the set point (P604) Set the set value (P604) from the operation panel or parameter unit. 1: AVI(0-10V) Terminal ^input is the set point (0—10DCV). 2: AVI(0-20mA) Terminal-HC input is the set point (0—20mA).</p>		
P603	PID feedback value selection	Default value 0
Setting Range:0~3		Unit:1
<p>Explanation: 0: AVI(0-10V) 1: AVI(0-20mA) 2/3: Reversed</p> <p>Notes:P603 parameter setting: Select PID feedback channel 0: AVI(0-10V) Input the signal from the detector (measured value signal (0— 10DCV)) 1: AVI(0-20mA) Input the signal from the detector (measured value signal (0— 20mA))</p>		

P604 PID figure target value setting

Default value 0

Setting Range:0~100%

Unit:0.01

Select AVI as feedback value

100% setting is corresponding to analog input 10V voltage.

PID closed-loop control is widely used to control the process such as pressure and temperature.

Feedback signal is given from temperature transmitter or pressure transmitter.

In case of PID control, the channel of feedback signal input is of analog signal (4 - 20mA or 0 - 10V). There are two channels available for setting.

Block diagram of PID control:

General regulation method for PID control:

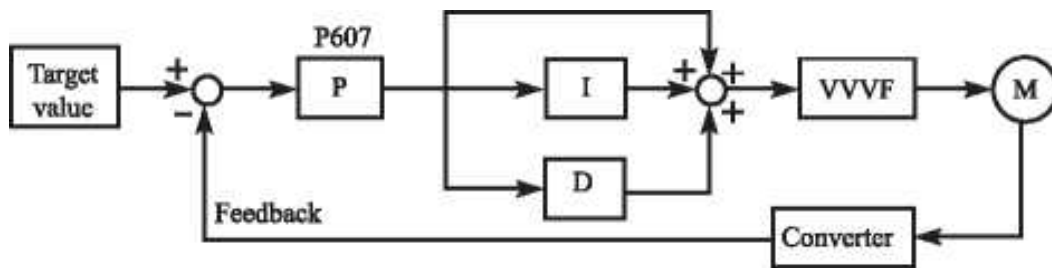

- (1) Select sensor/transmitter correctly, for which the standard signal of 4 - 20mA or 0 - 10V shall be selected as output specification.
- (2) Set PID action set point correctly.
- (3) Increase proportional constant (P), in case of non-oscillating output.
- (4) Decrease integration time (Ti), in case of non-oscillating output.
- (5) Increase differential (Td), in case of non-oscillating output.

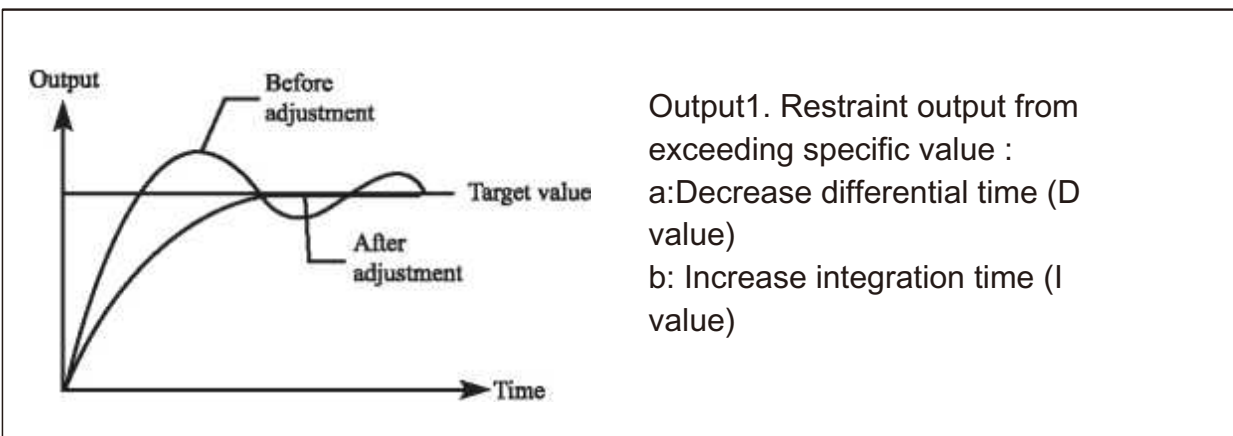

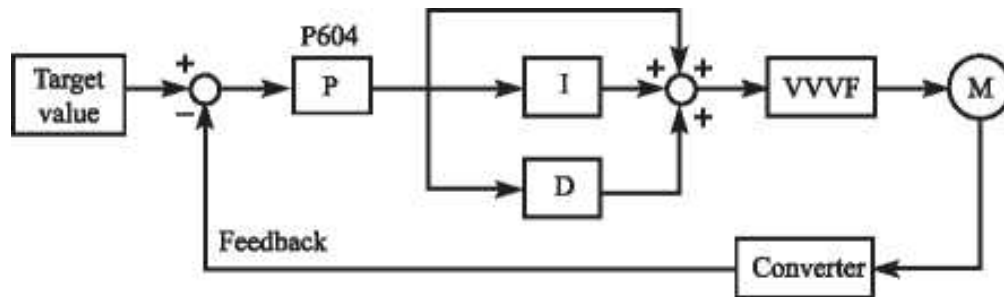
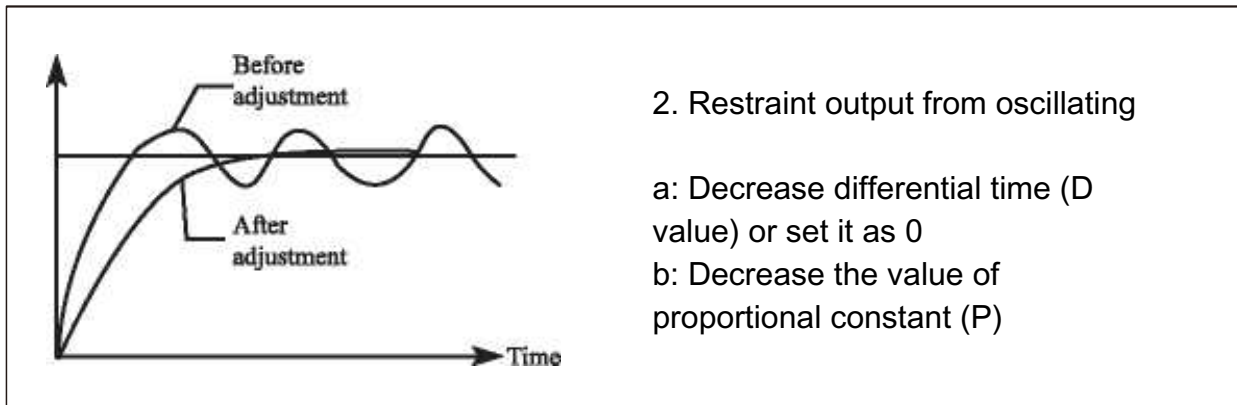

P605	PID upper limit alarm value	Default value 100
Setting Range:0.0~100%		Unit:0.1
Set the upper limit value. If the feedback value exceeds the setting, The alarm signal is output. The maximum input (20mA/10V) of the measured value (Terminal AVI) is equivalent to 100%.		
P606	PID lower limit alarm value	Default value 0
Setting Range:0.0~100%		Unit:0.1
Set the lower limit value. If the feedback value falls below the setting range, the alarm signal is output. The maximum input (20mA/10V) of the measured value (Terminal AVI) is equivalent to 100%.		
P607	PID proportional band	Default value 100%
Setting Range:0.0~200%		Unit:0.1
P607PID proportional bandInitial value :100%Setting range0.0-200%Unit0.1If the proportional band is narrow (parameter setting is small), the manipulated variable varies greatly with a slight change of the measured value. Hence, as the proportional band narrows, the response sensitivity (gain) improves but the stability deteriorates, e.g.hunting occurs.		

P608	PID integral time	Default value 0.3s
	Setting Range:0~200.0s	Unit:0.1
	For deviation step input, time(Ti) required for only the integral (I) action to provide the same manipulated variable as that for the proportional (P) action. As the integral time decreases, the set point is reached earlier but hunting occurs more easily.	
P609	PID differential time	Default value 0
	Setting Range:0.0~20.0	Unit:0.01
	For deviation ramp input, time (Td) required for providing only the manipulated variable for the proportional (P) action. As the differential time increases, greater response is made to a deviation change.	
P610	PID differential time	Default value 0.1
	Setting Range:0.0~1.0HZ	Unit:0.01
	PID is figured out once every 10ms. Frequency increment will be figured out (FHz) every time. While frequency increment is more than value of P610 in maximum of frequency increment, P610 will work.	
P611	PID standby frequency	Default value 0.0
	Setting Range:0.0~120.0HZ	Unit:0.01
P612	PID standby duration	Default value 10.0
	Setting Range:0.0~200.0HZ	Unit:0.1
P613	PID wake-up value	Default value 0.0%
	Setting Range:0.0~100%	
	P611 PID standby frequency. P611 must reach minimum frequency in PID standby. When running frequency is less than value of P610 standby duration will begin counting.	
	P612 PID standby duration. When running duration of inverter is more than standby frequency the value (standby duration) of P612, the inverter will be standby. Then stop output, and disconnect with PID, but monitor the feedback of P613PID.	
	P613: PID wake-up value. When the inverter detects that feedback value less than wake-up value (P613), PID function will be taken action, and then inverter will start.	

GroupP7 Initial settings and specifications of RS-485 communication

Used to perform required setting for communication between the inverter and personal computer.

P700 RS-485 Communication speed Factory Setting: 0

Setting Range:0~3

Unit:1

Explanation: 0: 4800bps 1: 9600bps 2: 19200bps 3: 38400bps

For example, the communication speed is 19200bps when the setting value is "2".

P701 Communication mode Factory Setting: 0

Setting Range:0~5

Unit:1

Explanation: 0: 8N1 For ASCII 1: 801 For ASCII 2: 8E1 For ASCII
 3: 8N1 For RTU 4: 801 For RTU 5: 8E1 For RTU

P701 sets the format of communication data. Please see related communication specification in detail.

P702 RS-485 communication station Factory Setting: 0

Setting Range:0~240

Unit:1

Each inverter must have a station number, which will be defined through P702.

Communication control of inverter can connect with 240 others.

If P702 is set to 0, means communication function is invalid.

FC100 Series Modbus Communication Protocol

Fc100 series communication agreement is with MODBUS ASCII (American standard code for information inter change) mode: Each byte consists of 2 ASCII characters, for example: The expression of the numerical value of 54Hex ASCII is that "54" consists of "5" (35Hex) and 4(34 Hex).

1. Definition of coding

Communication agreement belongs to hexadecimal system, of which each character represents the following information.

Character	"0"	"1"	"2"	"3"	"4"	"5"	"6"	"7"
ASCII code	30H	31H	32H	33H	34H	35A	36A	37A
Character	"8"	"9"	"A"	"B"	"C"	"D"	"E"	"F"
ASCII code	38A	39H	41H	42H	43A	44A	45H	46H

2. Character structure

10 - Bit character box (For ASCII)

Data pattern: 8N1 For ASCII

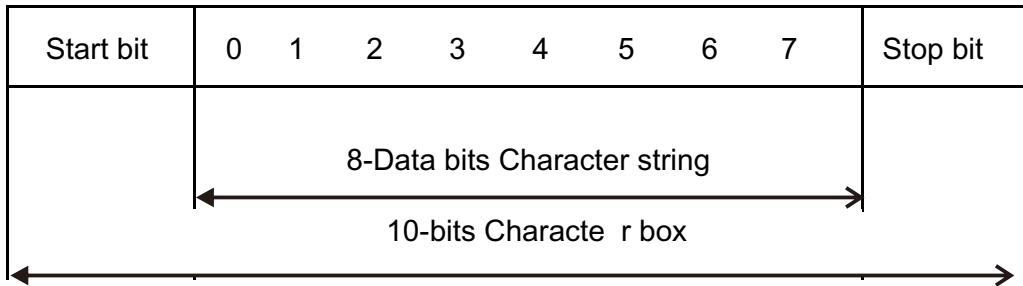

10 - Bit character box (For RTU) Data pattern: 8N1 For RTU

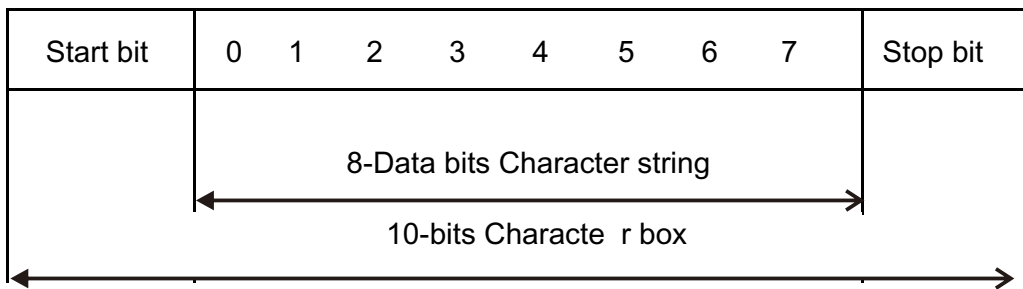

Data pattern: 8O1 For ASCII

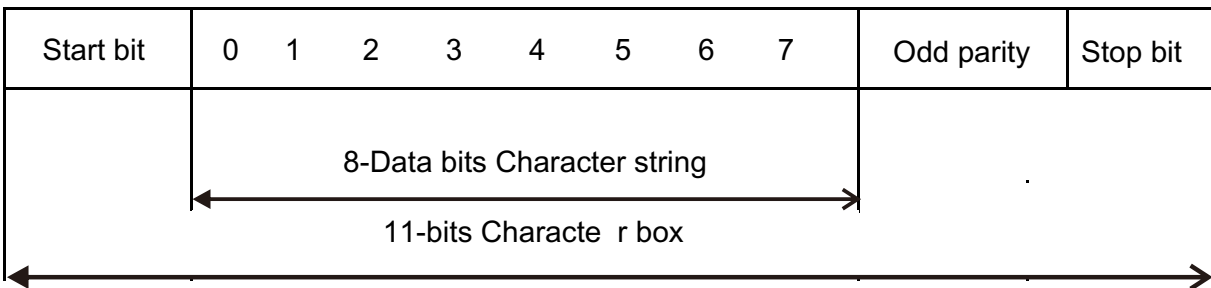

Data pattern: 8E1 For ASCII

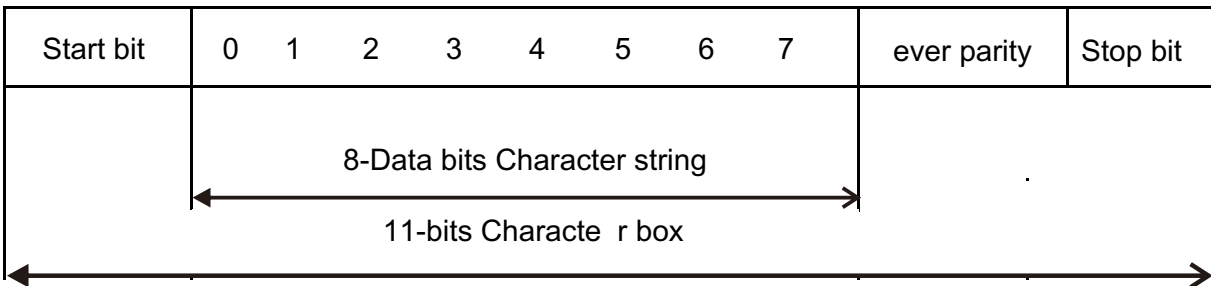

Data pattern: 801 For RTU

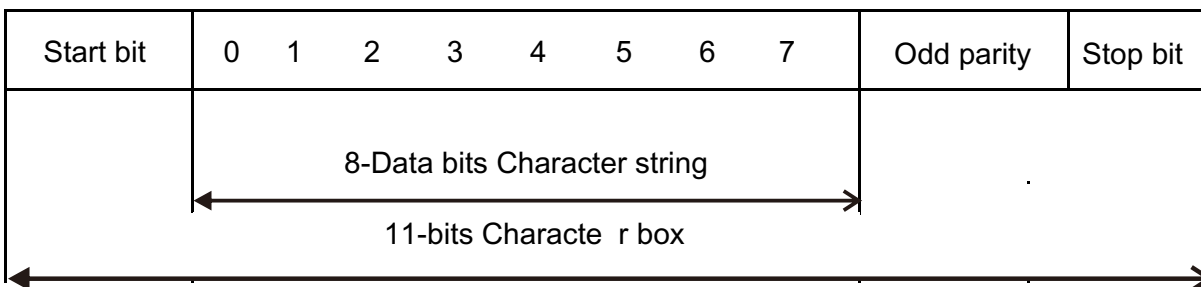

Data pattern: 8E1 For RTU

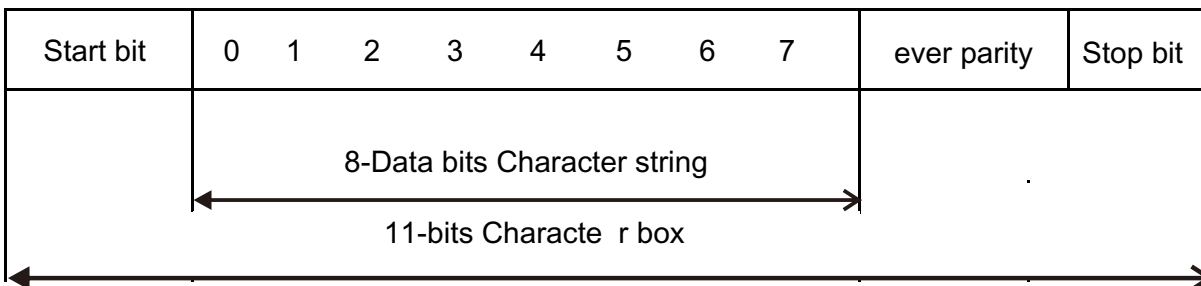

6

3. Structure of communication data

Data format box ASCII mode:

STX	Start character = ?(3AH)
Address Hi	Communication address:
Address Lo	8 bit address consists of 2 ASCII codes
Function Hi	Function code:
Function Lo	8 bit function code consists of 2 ASCII codes
DATA(n -1)	Data characters:
	n x 8 bit data content consists of 2n ASCII codes
DATA	n ^ 16, with the maximum of 32 ASCII codes
LRC CHK Hi	LRC Check:
LRC CHK Lo	8 bit LRC Check consists of 2 ASCII codes
END Hi	End character:
END Lo	END Hi = CR (0DH), END Lo = LF (0AH)

RTU mode:

START	Keep that zero - input signal is more than or equal to 10 ms
Address	Communication address: 8 - bit binary address
Function	Function code: 8 -bit binary address
DATA(n-1)	Data characters: n x 8 -bit data, n = 16
DATA0	
CRC CHK Low	CRC Check:
CRC CHK High	16-bit CRC Check consists of 2 8 -bit binary systems
END	Keep that zero-input signal is more than or equal to 10 ms

Communication Address

00H: All driver Broadcasts

01H: For inverter with 01st address

0FH: For inverter with 15th address

10H: For inverter with 16th address, by analogy, the maximum could reach 240.

Function code and Data Characters

03H: Read out the content of temporary storage

06H: Write a WORD into temporary storage; Function code 03H:

Read out the content of temporary storage.

For example: Driver address 01H, reads out the data characters in 2 successive temporary storages as follows: Initial temporary storage address 2102H

Function code 06H: Write a WORD into temporary storage.

Format of enquiry message
Character string

SIX	.
Address	1
	0
Function	0
	3
Starting address	2
	1
	0
	2
Number of data (count by word)	0
	0
	0
	2
LRC Check	D
	7
END	CR
	LF

Format of response message
Character string

SIX	
Address	0
	1
Function	0
	3
Number of data (count by byte)	0
	4
Content of starting address 2102H	1
	7
	7
	0
Content of address 2103 H	0
	0
	0
	0
LRC Check	7
	1
END	CR
	LF

ASCII mode:
RTU mode:
Format of enquiry message:

Address	01H
Function	03H
Starting data address	21H
	02H
Number of data (count by word)	00H
	02H
CRC CHK Low	6FH
CRC CHK High	F7H

Format of response message:

Address	01H
Function	03H
Number of data (count by word)	04H
Content of data address 8102H	17H
	70H
Content of data address 8103H	00H
	00H
CRC CHK Low	FEH
CRC CHK High	5CH

6

For example: Driver address 01H, writes 6000 (1770H) into the internal setting parameter 0100H of driver.

LRC Check of ASCII mode

Format of enquiry message
Character string

SIX	.
Address	0
	1
Function	0
	6
Data address	0
	1
	0
	0
Data Content	1
	7
	7
	0
LRC Check	7
	1
END	CR
	LF

Format of response message
Character string

SIX	.
Address	0
	1
Function	0
	6
Data address	0
	1
	0
	0
Data Content	1
	7
	7
	0
LRC Check	7
	1
END	CR
	LF

RTU mode:
Format of enquiry message:

Address	01H
Function	06H
Data Address	01H
	00H
Data Content	17H
	70H
CRC CHK Low	86H
CRC CHK High	22H

Format of response message:

Address	01H
Function	06H
Data Address	01H
	00H
Data Content	17H
	70H
CRC CHK Low	86H
CRC CHK High	22H

LRC Check is the value added from Address to Data Content. For example, the LRC Check of the above 3.3.1 enquiry message is as: 01H + 03H + 21H + 02H + 00H + 02H = 29H, then the complement of 2(D7H) is taken.

CRC Check of RTU mode

CRC Check is from Address to Data content, and its running rule is as follows:

Step 1: Make 16-bit temporary storage (CRC temporary storage)= FFFFH.

Step 2: Exclusive OR first 8-bit byte message instruction and low 16-bit CRC temporary storage: Perform Exclusive OR, and store the result into CRC temporary storage.

Step3: Move CRC temporary storage one more bit, and fill 0 into high bit position.

Step 4: Check right shift value, if being 0, store the new value for step 3 into CRC temporary storage, otherwise in case of Exclusive OR A001H and CRC temporary storage, store the result into CRC temporary.

Step 5: Repeat Step 3 ~ Step 4, and operate completely for 8-bit. Step

6: Repeat Step 2 ~ Step 5, and take the message instruction for next 8-bit, till all message instructions are operated completely.

Finally, the value gotten of CRC temporary storage is CRC Check. It is noteworthy that, CRC Check must be placed into the check mode of message instruction interchangeably.

The following is the example of CRC Check running written in C language:

```
Unsigned char * data //Message instruction pointer
Unsigned char length
<—//Length of message instruction
unsigned int crc_chk (unsigned char*data,
unsigned char length)
```

```
    unsigned int crc_chk (unsigned char*data, unsigned char length)
    {
        int j;
        unsigned int reg_crc=0Xffff;
        while( length-- ) {
            reg_crc^=*data ;
            for (j = 0; j<8; j ) {
                if (reg_crc & 0x01) { /*LSB (b0) =1 */
                    reg_ere= (reg_crc>>1) ^0Xa001;
                }else{
                    reg_cre=reg_crc>>1;
                }
            }
        }
        return reg_crc; //Finally feedback the value of CRC temporary storage
    }
```

Group P8: Advanced application parameters

P800	Advanced application parameter lock	Factory Setting:1
	Setting Range:0~1	Unit:1
	Explanation: 0: Lock 1: Unlock	
	If P800 is set to 0,you can not use the advanced parameters.	
P801	System 50Hz/60Hz selection	Factory Setting:0
	Setting Range:0~1	Unit:1
	Explanation: 0: 50HZ 1: 60HZ	
	50Hz/60Hz system could be set via the parameter according the condition of electric network.	
P802	constant and variable torque selection	Factory Setting:0
	Setting Range:0~1	Unit:1
	Explanation: 0: Constant torque 1: Variable torque	
	For fan and pump load, you can select “variable torque” for better energy saving.	
P803	Overvoltage protection setting	Factory Setting:Change
	Setting Range:760~820	Unit:1
	P803 sets DC-bus overvoltage protection level. This function could be used to avoid overvoltage protection during deceleration.	
P804	Undervoltage protection setting	Factory Setting:Change
	Setting Range:380~450	Unit:1
	P804 sets voltage protection level. If the input voltage is low, inverter is easy to trip for undervoltage. This function could be used to avoid inverter protection undervoltage	
P805	Over temperature protection setting	Factory Setting:Change
	Setting Range:40~120	Unit:1
	P805 sets the over temperature protection level of inverter. In high temperature environment, the protection level could be improved appropriately, to guarantee the normal running of inverter. However, too high setting value will result in IGBT damage, so the only solution is to improve the effect of heat elimination, so as to achieve the goal of cooling down	

P806	Current display filter time	Factory Setting:2.0
-------------	-----------------------------	---------------------

Setting Range:0~100	Unit:1
---------------------	--------

This parameter setting is relevant to the stabilization of current display, and shall not be modified in general. If the setting is too small, current display will fluctuate.

P807	0-10V analogue output low end calibration coefficient
-------------	---

Setting Range:0~9999	Unit:1
----------------------	--------

P808	0-10V analog output high end calibration coefficient
-------------	--

Setting Range:0~9999	Unit:1
----------------------	--------

P809	0-20mA analogue output low end calibration coefficient
-------------	--

Setting Range:0~9999	Unit:1
----------------------	--------

P810	0-20mA analog output high end calibration coefficient
-------------	---

Setting Range:0~9999	Unit:1
----------------------	--------

The above parameters are factory default setting, normally shall not be adjusted, otherwise it may cause abnormal operation.



Chapter 7

Maintenance and Inspection

CHAPTER 7 MAINTENANCE AND INSPECTIONS

Modern AC drives are based on solid state electronics technology, preventive maintenance is required to operate this AC drive in its optimal condition, and to ensure a long life. It is recommended to perform a monthly check up of the AC drive by a qualified technician. Before the check up, always turn off the AC Input Power to the unit. Wait at least 2 minutes after all display lamps have gone out.

6.1 Periodic Inspection:

Basic check up items to detect if there were any abnormality during the operation:

1. Whether the motors are operating as expected.
2. Whether the installation environment is abnormal.
3. Whether the cooling system is operating as expected.
4. Whether any irregular vibration or sound occurred during the operation.
5. Whether the motors are overheated during the operation.
6. Always check the input voltage of the AC drive with Voltmeter.

6.2 Periodic Maintenance

 **WARNING!** Disconnecting AC power before processing!

1. Tighten and reinforce the screws of the AC drive if necessary, cause it may loose due to the vibration or changing of temperatures.
2. Whether the conductors or insulators were corroded and damaged.
3. Check the resistance of the insulation with Mega-ohmmeter.
4. Often check and change the capacitors and relays.
5. If use of the AC drive is discontinued for a long period of time, turn the power on at least once every two years and confirm that it still functions properly. To confirm functionality, disconnect the motor and energize the AC drive for 5 hours or more before attempting to run a motor with it.
6. Clean off any dust and dirt with a vacuum cleaner. Place special emphasis on cleaning the ventilation ports and PCBs. Always keep these areas clean, as accumulation of dust and dirt can cause unforeseen failures.



Chapter 8

Troubleshooting and Fault Information

This Chapter Content

This chapter briefly introduces the operation principle, product performance, layout, nameplate, and type of instructions.

CHAPTER 8 Troubleshooting and Fault Information

The FC100 AC drive has a comprehensive fault diagnostic system that includes several different alarms and fault messages. Once a fault is detected, the corresponding protective functions will be activated. The following faults are displayed on the AC drive digital keypad. The six most recent faults can be read on the digital keypad display by viewing

NOTE: Faults can be cleared by a reset from the keypad or Input Terminal.

Common Problems and Solutions:

Operation Panel Indication	Name	Possible fault reason	Corrective action
oco/uco	Over current during stop	1: Inverter fault	Please contact your sales representative.
OC1/UC1	Over current during acceleration	1: Acceleration time is too short 2: V/F curve is not set correctly 3: Motor or motor wire have short circuit to the ground 4: The torque boost is set too fast 5: The input voltage is too low 6: Directly start up the running motor 7: The inverter setting is not correct 9: The inverter fails	1; Increase acceleration time 2; Correctly set V/F curve. 3; Check the insulation of motor and motor wire. 4: Reduce the value of torque boost. 5: Check input voltage 6: Check the load 7; Set tracing startup 8: Enlarge capacity of inverter 9: Sent for repairing
OC2/UC2	Over current during deceleration	1: Decelerate time is too short 2: Inverter capacity is inappropriately set 3: Whether there is any disturbing	1: Increase deceleration time 2: Enlarge inverter capacity 3: Solve disturbing resource

Operation Panel Indication	Name	Possible fault reason	Corrective action
OC3/UC3	Over current during constant speed	1: The insulation of motor and motor wire is not good 2: Load fluctuation 3: Fluctuation of input voltage and the voltage is low 4: Inverter capacity is inappropriately set 5: Whether there is a large power motor starting up and leads the input voltage goes down 6: Whether there is a disturbing resource to disturb inverter	1: Check the insulation of motor and motor wire 2: Check load situation and mechanical lubrication 3: Check input voltage 4: Enlarge the capacity of inverter 5: Increase capacity of transformer 6: Solve disturbing resource
OUO	Over voltage during stop	1: The deceleration time is short 2: Inverter capacity incorrectly set 3: Disturbing	1: Check the power supply voltage 2: Sent for repairing
OU1	Over voltage during acceleration	1: Abnormal power supply 2: Peripheral circuitry is incorrectly set (switch control on or off, etc.) 3: Inverter fault	1: Check the power supply voltage 2: Do not use power supply switch to control the inverter on or off 3: Sent for repairing
OU2	Over voltage during deceleration	1: Power supply voltage abnormal 2: Energy feedback load 3: Braking resistor incorrectly set	1; Check the power supply voltage 2; Install braking unit and resistance 3: Affirm resistance setting again
OU3	Over voltage during constant speed	1: Decelerate time is too short 2: Power supply voltage abnormal 3: Over load 4: Braking resistor incorrectly set 5: Braking parameter is incorrectly set	1: Increase deceleration time 2: Check the power supply voltage 3: Check braking unit and resistance 4: Set Braking resistor over again 5: Correctly set parameter, e.g. braking tube voltage, etc.

Operation Panel Indication	Name	Possible fault reason	Corrective action
LU0	Under voltage during stop	1: Power supply voltage abnormal 2: Phase missing	1: Check the power supply voltage 2: Check power supply and switch whether there is phase missing
LU1	Under voltage during acceleration	1: Power supply voltage abnormal 2: Phase missing 3: There is large load power start up in the input	2: Check whether peripheral setting bad connection leads phase missing 3: Please use independent power supply
LU2	Under voltage during deceleration		
LU3	Under voltage during constant speed		
Fb0	Fuse broken	1: The inverter fault	Please contact your sales representative.
Fb1			
Fb2			
Fb3			
OLO during stop	Inverter overload	1: Overload 2: Acceleration time is too short 3: Torque boost is too fast 4: V/F curve incorrectly set 5: Under voltage of input 6: Before motor stops, inverter starts up 7: Fluctuation or blocking in loading	1; Reduce the load weight or replace larger capacity inverter. 2: Increase acceleration time 3: Reduce torque boost rate 4: Set V/F curve over again 5: Check input voltage, increase inverter capacity 6: Adopt tracing startup mode 7: Check load
OL1 during acceleration			
OL2 during deceleration			
OL3 during constant speed			

Operation Panel Indication	Name	Possible fault reason	Corrective action
OTO during stop	Motor overload	1: The motor for use under overload 2: Acceleration time is too short 3: Motor protection setting is too small 4: V/F curve is incorrectly set 5: Torque boost is too fast 6: Bad motor insulation 7: Motor setting is too small	1: Reduce the load weight. 2: Increase acceleration time 3: Increase protection setting 4: Correctly set V/F curve 5: Reduce torque boost rate 6: Check motor insulation and replace motor 7; Use larger inverter or motor
OT1 during acceleration			
OT2 during deceleration			
OT3 during constant speed			
OHO during stop	Inverter overheat	1: Cooling fan broken 2: Heatsink clogging 3: The ambient temperature is high	1: Replace the cooling fan. 2: Clean the heatsink 3: Set the ambient temperature to within the specifications.
OH1 during acceleration			
OH2 during deceleration			
OH3 during constant speed			
ES	Emergency stop	1: Inverter is in Emergency stop condition	1; After release Emergency stop, start up as regular procedure
CO	Communication error	1: Communication line connection has problem 2: Communication parameter is incorrectly set 3: Transmission format is wrong	1: Perform wiring of the RS - 485 terminals properly. 2: Set parameter over again 3: Check data transmission format
20	4- 20mA wire broken	1: Terminal is loose; signal input line is bad connected	1: Perform wiring of the 4 - 20mA terminals properly.
Pr	Parameter write error	Parameter setting is wrong	After stopping operation, make parameter setting.
Err	Wrong parameter group	parameter does not exist or the factory setting parameter	Quit this parameter

8-4 Check first when you have troubles

If the causes is still unknown after every check, it is recommended to initialize the parameters (initial value) then reset the required parameter values and check again.

(1) Parameter write cannot be performed Causes and corrective actions:

a: Check P118 parameter write selection.

b: Check P101 Frequency setting/P102 Operation mode setting selection.

c: Make sure that operation is not being performed. Please stop the inverter and set.

(2) Motor does not rotate as commanded Causes and corrective actions:

a: Check that the P102 Operation mode selection setting is correct, b: Check that the starting frequency setting is not greater than the running frequency.

c: Check the main circuit and control circuit, d: Check that the output stop signal or reset signal is not on. e: Check that P104 Reverse rotation prevention selection is not selected.

f: Check that frequency setting of each running frequency (such as multi-speed operation) are not zero.

g: Check that especially the P105 Maximum frequency setting in not zero.

h: Check that the P400 Jog frequency setting is not lower than the P202 starting frequency setting, i: Check that the load is not too heavy.

(3) Motor generates heat abnormally Causes and corrective actions:

a: Check that the load is not too heavy. Lighten the load.

b: Is the fan for the motor is running ? (check for accumulated dust.) c: Check that the P208 Torque boost setting is correct, d: Was the motor type set? Check the setting of P209 to P219 applied motor.

e: When using any other manufacturer's motor , perform offline auto tuning.

(4) Motor generates abnormal noise Causes and corrective actions:

a: No carrier frequency noises (metallic noises) are generated.

Check the setting of P115 applied motor, b: Check for any mechanical looseness, c: Contact the motor manufacturer.

(5) Motor rotates in opposite direction Causes and corrective actions:

a: Check that the phase sequence of output terminals U,V and W is correct.

b: Check that the start signals (forward rotation, reverse rotation)are connected properly.

(6) Speed does not increase Causes and corrective actions:

a: Check that the maximum frequency (P105)setting is correct. (If you want to run the motor at 120Hz or more, set P105 High speed maximum frequency.)

b: Check that the load is not too heavy. (In agitators, etc, load may become heavier in winter.)

(7) Inverter may interfere with other devices.

Causes and corrective actions:

The input/output (main circuit) of the inverter includes high frequency components, which may interfere with the communication devices used near the inverter. In this case, set EMC filter valid to minimize interference.

a: Decrease carrier frequency (P115).

b: Install a noise filter on the inverter output side to reduce the electromagnetic noise generated from the inverter.

c: Install a noise filter on the inverter input side.

d: For reduction of induction noise from the power line of the inverter, it is recommended to wire the earth cable by returning it to the earth terminal of the inverter.

e: To prevent a malfunction due to noise, keep the signal cables more than 10cm away from the power cables, f: Control circuit cable should use shielded cable, and the cable should be installed in metal tube

8-5 Inverter-generated noises and their reduction techniques

Some noises enter the inverter to malfunction it and others are radiated by the inverter to malfunction peripheral devices. Though the inverter is designed to be insusceptible to noises, it handles low-level signals, so it requires the following basic techniques. Also, since the inverter chops outputs at high carrier frequency, that could generate noises. If these noises cause peripheral devices to malfunction, measures should be taken to suppress noises. These techniques differ slightly depending on noise propagation paths.

1, Basic techniques

- Do not run the power cables (I/O cables) and signal cables of the inverter in parallel with each other and do not bundle them.
- Use twisted pair shielded cables for the detector connection and control signal cables, and connect the sheathes of the shield cables to terminal SC.
- Earth the inverter, motor, etc, at one point.

2, Techniques to reduce noises that enter and malfunction the inverter

When devices that generate many noises (which use magnetic contactors, magnetic brakes, many relays, for example) are installed near the inverter and the inverter may be malfunctioned by noises, the following measures must be taken:

Provide surge suppressors for devices that generate many noises to suppress noises.

- Fit data line filters to signal cables.
- Earth the shields of the detector connection and control signal cables with Cable clamp metal.

Noise reduction examples

