

Preface

Thank you very much for buying AD300 series inverter

The AD300 series inverter is a kind of high-performance vector control inverter. The product adopts speed sensorless vector control technology, the internationally leading technology and combines the application characteristics of China to further enhance the product reliability, environment adaptability and customized and industrialized design. It can better meet the demands of the various drive applications. The product adopts speed senseless vector control technology.

This manual provides the user with a guide on installation & wiring, parameter setting, daily maintenance, fault diagnosis and troubleshooting. The user is required to peruse the whole content of the manual carefully and be familiarized with the relevant know-how and notes on inverter safety before any attempts of installation, setting, operation and maintenance.

The technical specifications applied to this product or the content of this manual may be subject to any change without prior notifying.

This manual is required to be kept properly until the inverter is out of its service life.

Safety Precautions

Description of safety marks:



Danger: The misuse may cause fire, severe injury, even death.



Note: The misuse may cause medium or minor injury and equipment damage.

■ Use



Danger

- This series of inverter is used to control the variable speed operation of three-phase motor and cannot be used for single-phase motor or other applications. Otherwise, inverter failure or fire may be caused.
- This series of inverter cannot be simply used in the applications directly related to the human safety, such as the medical equipment.
- This series of inverter is produced under strict quality management system. If the inverter failure may cause severe accident or loss, safety measures, such as redundancy or bypass, shall be taken.

■ Goods Arrival Inspection



Note

- If the inverter is found to be damaged or lack parts, the inverter cannot be installed. Otherwise, accident may be caused.

■ Installation



Note

- When handling and installing the product, please hold the product bottom. Do not hold the enclosure only. Otherwise, your feet may be injured and the inverter may be damaged because of dropping.
- The inverter shall be mounted on the fire retardant surface, such as metal, and kept far away from the inflammables and heat source.
- The inverter shall be mounted on the fire retardant surface, such as metal, and kept far away from the inflammables and heat source. Keep the drilling scraps from falling into the inside of the inverter during the installation; otherwise, inverter failure may be caused.
- When the inverter is installed inside the cabinet, the electricity control cabinet shall be equipped with fan and ventilation port. And ducts for radiation shall be constructed in the cabinet.

■ Wiring



Danger

- The wiring must be conducted by qualified electricians. Otherwise, there exists the risk of electric shock or inverter damage.
- Before wiring, confirm that the power supply is disconnected. Otherwise, there exists the risk of electric shock or fire.
- The grounding terminal PE must be reliably grounded, otherwise, the inverter enclosure may become live.
- To ensure the safety, the inverter and the motor must be grounded. Please do not touch the main circuit terminal. The wires of the inverter main circuit terminals must not contact the enclosure. Otherwise, there exists the risk of electric shock.
- The connecting terminals for the braking resistor are (+) and PB. Please do not connect terminals other than these two. Otherwise, fire may be caused.

■ Wiring



Note

- The three-phase power supply cannot connect to output terminals U/T1, V/T2 and W/T3, otherwise, the inverter will be damaged.
- It is forbidden to connect the output terminal of the inverter to the capacitor or LC/RC noise filter with phase lead, otherwise, the internal components of the inverter may be damaged
- Please confirm that the power supply phases, rated voltage are consistent with that of the nameplate, otherwise, the inverter may be damaged.
- The wires of the main circuit terminals and the wires of the control circuit terminals shall be laid separately or in a square-crossing mode, otherwise, the control signal may be interfered.
- When the length of the cables between the inverter and the motor is more than 100m, it is suggested to use output reactor to avoid the inverter failure caused by the overcurrent of the distribution capacitor.
- The inverter which equipped with DC reactor must connect with DC reactor between the terminal of P1、(+) otherwise the inverter will not display after power on.

■ Operation



Danger

- Power supply can only be connected after the wiring is completed and the cover is installed. It is forbidden to remove the cover in live condition; otherwise, there exists the risk of electric shock.
- When auto failure reset function or restart function is set, isolation measures shall be taken for the mechanical equipment, otherwise, personal injury may be caused.
- When the inverter is powered on, even when it is in the stop state, the terminals of the inverter are still live. Do not touch the inverter terminals; otherwise electric shock may be caused.
- The failure and alarm signal can only be reset after the running command has been cut off. Otherwise, personal injury may be caused.

**Note**

- Do not start or shut down the inverter by switching on or off the power supply, otherwise, the inverter may be damaged.
- Before operation, please confirm if the motor and equipment are in the allowable use range, otherwise, the equipment may be damaged.
- The heatsink and the braking resistor have high temperature. Please do not touch such device; otherwise, you may be burnt.
- When it is used on lifting equipment, mechanical contracting brake shall also be equipped.
- Please do not change the inverter parameter randomly. Most of the factory set parameters of the inverter can meet the operating requirement, and the user only needs to set some necessary parameters. Any random change of the parameter may cause the damage of the mechanical equipment.
- In the applications with industrial frequency and variable frequency switching, the two contactors for controlling the industrial frequency and variable frequency switching shall be interlocked.

■ Maintenance, Inspection**Danger**

- In the power-on state, please do not touch the inverter terminals; otherwise, there exists the risk of electric shock.
- If cover is to be removed, the power supply must be disconnected first.
- Wait for at least 10 minutes after power off or confirm that the CHARGE LED is off before maintenance and inspection to prevent the harm caused by the residual voltage of the main circuit electrolytic capacitor to persons.
- The components shall be maintained, inspected or replaced by qualified electricians.

**Note**

- The circuit boards have large scale CMOS IC. Please do not touch the board to avoid the circuit board damage caused by electro static.

Contents

Charper 1 Introduction to AD300 Series Inverter	1
1.1 Product Model Description	1
1.2 Product Nameplate Description	1
1.3 Product Series.....	2
1.4 Technical Specifications of Product.....	4
1.5 Product Outline, Mounting Dimension.....	5
1.6 Operating Panel Outline and Mounting Dimension	7
1.7 Operating Panel Outline and Mounting Dimension	7
1.8 Braking Resistor Lectotype.....	8
Chapter 2 Inverter Installation	9
2.1 Environment for Product Installation.....	9
2.2 Mounting Direction and Space	9
2.3 Removal and Mounting of Operation Panel and Cover.....	10
Chapter 3 Wiring of Inverter.....	11
3.1 Connection of the Product and Peripheral Devices	11
3.2 Description of Peripheral Devices for Main Circuit	12
3.3 Lectotype of Main Circuit Peripheral Devices	13
3.4 Terminal Configuration Of Main Circuit	14
3.5 Attention for Main Circuit Wiring	15
3.6 Terminal Wiring	18
3.7 Functions of Control Circuit Terminals	20
3.8 Control board schematic drawing	24
3.9 control circuit Periphery component shaping	25
3.10 code switch function explanation.....	25
Chapter 4 Operation and Display	26
4.1 Introduction to Operation and Display Interface	26
4.2 Description of Function Code Viewing and Modification Methods	28
4.3 Display status of keyboard	29
4.4 Password Setting.....	29
Chapter 5 List of Parameters	30
Chapter 6 Parameter description.....	51
6.1 Group 0 Basic Function	51
6.2 Group 1 Start and Stop Control.....	56
6.3 Group 2 Auxiliary Function	59
6.4 Group 3 Vector Control Parameters	63
6.5 Group 4 V/F Control Parameters	65

6.6 Group 5 Motor Parameters.....	68
6.7 Group 6 Input Terminal.....	69
6.8 Group 7 Output Terminal.....	76
6.9 Group F8 PID Parameters.....	81
6.10 Group F9 Multi-step speed and PLC.....	85
6.11 Group FA Swing Frequency Operating.....	88
6.12 Group FB Fixed-length.....	89
6.13 Group FC Protection and Fault Parameters.....	89
6.14 Group FD Communication Parameters.....	91
6.15 Group FE Keyboard and Display.....	92
6.16 Group FF Running History Record.....	94
6.17 Group FP Protection Parameters.....	95
Chapter 7 Fault information and solutions.....	97
7.1 Fault information and solutions.....	97
7.2 Warning information.....	99
7.3 The general fault diagnosis and solutions.....	99
Chapter 8 Routine Repair and Maintenance.....	100
8.1 Routine Maintenance.....	100
8.2 Periodic Maintenance.....	101
8.3 Component Replacement.....	101
8.4 Warranty.....	101
Apendix A Modbus Communication Protocol.....	103

Charper 1 Introduction to AD300 Series Inverter

1.1 Product Model Description

The digits and letters in the inverter model field on the nameplate indicate such information as the product series, power supply class, power class and software/hardware versions.

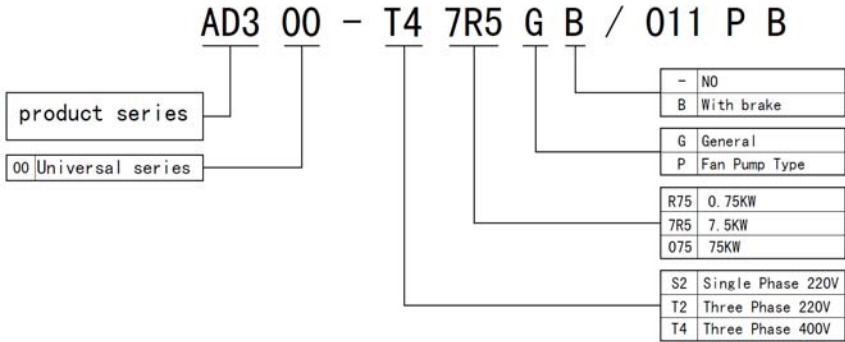

Fig.1-1 Product Model Description

1.2 Product Nameplate Description

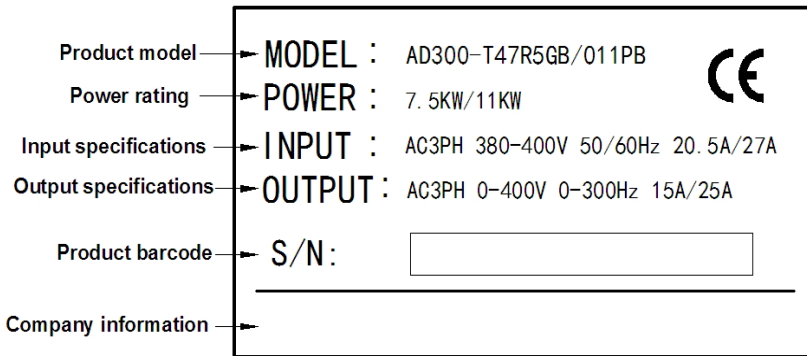

Fig.1-2 Product Nameplate Description

1.3 Product Series

■ AD300-T4□□□G(B) Three-phase 400V Constant torque/heavy-duty application

Power (kW)		2.2	4	5.5	7.5	11	15	18.5	22	30	37	45	55	75	90	110
Motor power (kW)		2.2	4	5.5	7.5	11	15	18.5	22	30	37	45	55	75	90	110
Output	Voltage (V)	Three-phase 0 to rated input voltage														
	Rated current (A)	6.0	9.0	13	17	25	32	37	45	60	75	90	110	150	176	210
	Overload capacity	150% 1 minute, 180% 20 seconds,														
Input	Rated voltage/frequency	Three-phase 380V/440V; 50Hz/60Hz														
	Allowable voltage range	304V ~ 456V; Voltage unbalancedness ≤3%; allowable frequency fluctuation: ±5%														
	Rated current (A)	7.0	10.7	15	20.5	27	35	38.5	46.5	62	76	92	113	157	180	214
Braking unit		Built-in as standard							Need external							
Protection class		IP20														
Cooling mode		Forced air convection cooling														
Power (kW)		132	160	200	220	250	280	315								
Motor power (kW)		132	160	200	220	250	280	315								
Output	Voltage (V)	Three-phase 0 to rated input voltage														
	Rated current (A)	250	300	380	420	470	540	600								
	Overload capacity	150% 1 minute, 180% 20 seconds,														
Input	Rated voltage/frequency	Three-phase 380V/440V; 50Hz/60Hz														
	Allowable voltage range	304V ~ 456V; Voltage unbalancedness ≤3%; allowable frequency fluctuation: ±5%														
	Rated current (A)	256	307*	385*	430*	480*	548*	610*								
Braking unit		Need external														
Protection class		IP20														
Cooling mode		Forced air convection cooling														

* AD300-T4160G and above products are equipped with external DC reactor as standard.

■ AD300-T4□□P(B) Three-phase 400V Variable torque/light-duty application

Power (kW)	4	5.5	7.5	11	15	18.5	22	30	37	45	55	75	90	110	132	
Motor power (kW)	4	5.5	7.5	11	15	18.5	22	30	37	45	55	75	90	110	132	
Output	Voltage (V)	Three-phase 0 to rated input voltage														
	Rated current (A)	9.0	13	17	25	32	37	45	60	75	90	110	150	176	210	250
	Overload capacity	120% 1 minute, 150% 1 seconds,														
Input	Rated voltage/frequency	Three-phase 380V/440V; 50Hz/60Hz														
	Allowable voltage range	304V ~ 456V; Voltage unbalancedness ≤3%; allowable frequency fluctuation: ±5%														
	Rated current (A)	10.7	15.5	20.5	26	35	38.5	46.5	62	76	92	113	157	180	214	256
Braking unit	Built-in as standard							Need external								
Protection class	IP20															
Cooling mode	Forced air convection cooling															
Power (kW)	160	200	220	250	280	315	355									
Motor power (kW)	160	200	220	250	280	315	355									
Output	Voltage (V)	Three-phase 0 to rated input voltage														
	Rated current (A)	300	380	420	470	540	600	660								
	Overload capacity	120% 1 minute, 150% 1 seconds,														
Input	Rated voltage/frequency	Three-phase 380V/440V; 50Hz/60Hz														
	Allowable voltage range	304V ~ 456V; Voltage unbalancedness ≤3%; allowable frequency fluctuation: ±5%														
	Rated current (A)	307	385*	430*	480*	548*	610*	680*								
Braking unit	Need external															
Protection class	IP20															
Cooling mode	Forced air convection cooling															

* AD300-T4200P and above products are equipped with external DC reactor as standard.

1.4 Technical Specifications of Product

Control features	Control mode	Closed-loop vector control	Open-loop vector control	V/F control
	Startup torque	0.00Hz 180%	0.5Hz 150%	1.5Hz 150%
	Speed adjustment range	1:1000	1:100	1:50
	Speed stabilization precision	± 0.02%	± 0.2%	± 0.5%
	Torque control	Y	Y	N
	Torque precision	± 5%	± 10%	----
	Torque response time	<10ms	<20ms	----
Product functions	Key functions	Torque / speed control mode switching、 Multi-function input / output terminal、 Under voltage adjustment、 switching of AC operation grounding, protective grounding and DC operation grounding、 rotation speed tracing、 torque limitation、 multi-speed operation、 auto-tuning、 S curve acceleration/deceleration、 slip compensation、 PID adjustment、 simple PLC、 Length control、 drooping control、 current limiting control、 manual/auto torque increase、 current limiting、 AVR Function		
	Frequency setting mode	Operation panel setting, terminal UP/DN setting, host computer communication setting, analog setting AI1/AI2, terminal pulse X4/X5 setting		
	Frequency range	0.00~300.00Hz		
	Startup frequency	0.00~60.00Hz		
	Acceleration/deceleration time	0.1~3600s		
	Powered braking capacity	Inverter of 400V voltage grade: Braking unit action voltage: 650 ~ 750V Inverter of 200V voltage grade: Braking unit action voltage: 360 ~ 390V Operating time: 100.0s		
	DC braking capacity	DC braking initial frequency:0.00~300.0Hz; DC braking current: Constant torque:0.0~100.0%; Variable torque: 0. 0~80.0% DC braking time:0.0~30.0s; there is no initial waiting time for the DC braking to realize quick braking		
	Magnetic flux braking function	Ongoing action and no action upon deceleration as option, no action upon deceleration at default		
Unique functions	Multifunctional MFK key	The unique multifunctional key is used to set the frequently used operations: JOG, emergency shutdown, running command reference mode switch		
	Parameter copy	The standard operation panel can realize the parameter upload, download. The user can select to forbid the overwriting of the uploaded parameters.		
	Operation panel	Optional LED display or LCD-type display panel type		
	Common DC bus	The full series can realize common DC bus supply for several inverters.		

	Independent duct	The full series adopts independent duct design and supports the installation of heatsink outside the cabinet
	Expansion card	IO Expansion card、injection molding machine interface card
	Power-up auto-detection	Realizing the power-up auto-detection of internal and peripheral circuits
Protection function	Power supply under voltage、overvoltage protection、over current protection、auto-tuning failure、module protection、heatsink overtemperature protection、inverter overload protection、motor overload protection、peripheral protection、output to ground short circuit、abnormal power failure during operation、abnormal input power、output phase failure、abnormal EEPROM、abnormal relay contact、temperature sampling disconnection、encoder disconnection、bnormal 10V power supply output、abnormal analog input、abnormal communication、abnormal version compatibility、abnormal copying、abnormal expansion card connection、hardware overload protection	
Efficiency	At rated power, 7.5kW and below power class $\geq 93\%$, 45kW and below power class $\geq 95\%$, 55kW and above power class $\geq 98\%$	
Environment	Operating site	The product shall be mounted vertically in the electric control cabinet with good ventilation. Horizontal or other installation modes are not allowed. The cooling media is the air. The product shall be installed in the environment free from direct sunlight, dust, corrosive gas, combustible gas, oil mist, steam and drip.
	Ambient temperature	-10 ~ +40°C, derated at 40 ~ 50°C, the rated output current shall be decreased by 1% for every temperature rise of 1°C
	Humidity	5~95%, no condensing
	Altitude	0 ~ 2000m, derated above 1000m, the rated output current shall be decreased by 1% for every rise of 100m
	Vibration	3.5mm, 2~9Hz; 10 m/s ² , 9~200Hz; 15 m/s ² , 200~500Hz
	Storage temperature	-40~+70°C

1.5 Product Outline, Mounting Dimension (Unit: mm)

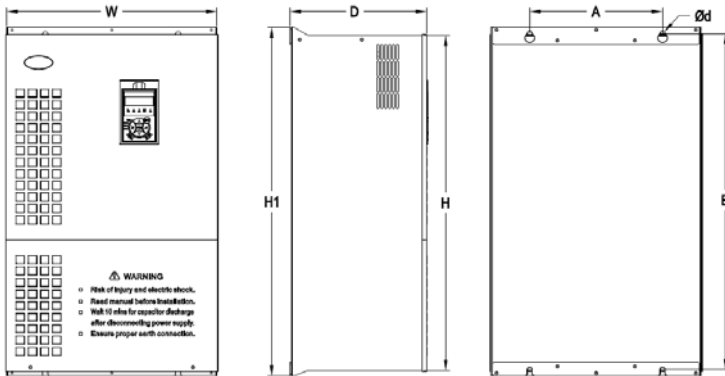

Fig.1-3 Product Outline, Mounting Dimension Schematic diagram

Inverter Model	H	W	D	H1	A	B	d
AD300-T41R5GB/2R2PB AD300-T42R2GB/4R0PB AD300-T44R0GB/5R5PB	210	133	180	238	108	225	7
AD300-T45R5GB/7R5PB AD300-T47R5GB/011PB	258	155	180	285	120	270	7
AD300-T4011GB/015PB AD300-T4015GB/018PB	330	200	195	355	150	340	7
AD300-T4018G/022P AD300-T4022G/030P AD300-T4030G/037P	425	270	200	450	200	430	7
AD300-T4037G/045P-A	517	324	213	547	240	525	9
AD300-T4037G/045P AD300-T4045G/055P AD300-T4055G/075P	535	320	248	560	240	540	9
AD300-T4075G/093P AD300-T4093G/110P AD300-T4110G/132P	640	380	248	665	240	640	9
AD300-T4132G/160P	1100	400	400	1120	300	1090	11
AD300-T4132G/160P-U AD300-T4132G/160P-D AD300-T4160G/185P-U AD300-T4160G/185P-D	710	465	355	750	380	719	11
AD300-T4160G/200P-H AD300-T4200G/220P-H AD300-T4220G/250P-H	1400	400	400	1400	460	1270	13
AD300-T4250G/280P-H AD300-T4280G/315P-H AD300-T4315G/355P-H	1600	500	420	1600	560	1460	13
AD300-T4355G/400P-H AD300-T4400G/450P-H AD300-T4450G/500P-H AD300-T4500G/560P-H	1800	780	450	1800	840	1630	13
AD300-T4560G/630P-H AD300-T4630G/710P-H AD300-T4710G/800P-H AD300-T4800G/900P-H	1800	1560	500	1800			

Note:

- H refers to cabinet type machine with DC reactor.
- U means input lines come from upside and output lines come out downside.
- D means input lines come from downside and output lines come out downside.

1.6 Operating Panel Outline and Mounting Dimension (Unit: mm)

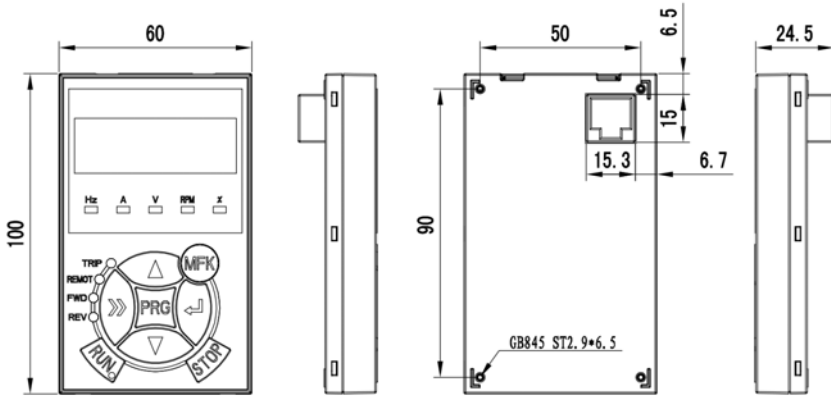
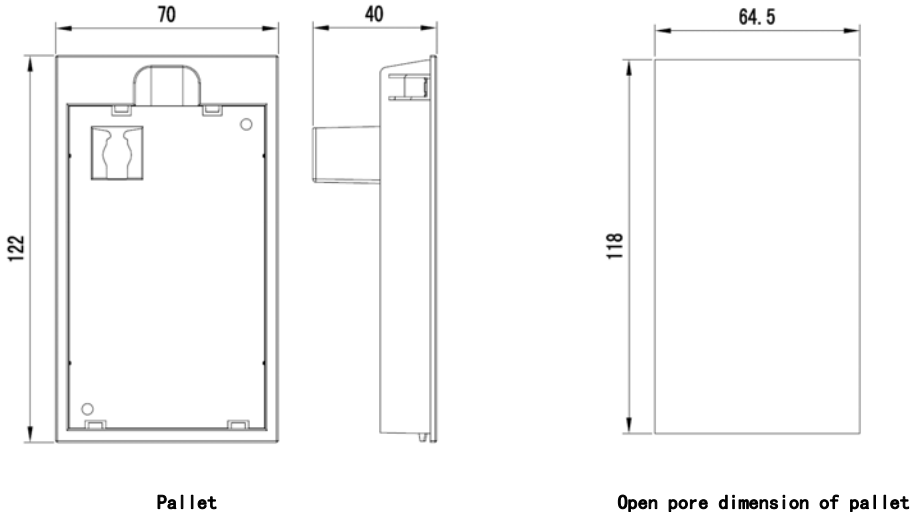

Fig.1-4 Operating Panel Outline and Mounting Dimension

1.7 Operating Panel Outline and Mounting Dimension

KB-SAL01 is the mounting pallet when the operation panel is to install on the electric control cabinet. The outline and dimension are as follows: (Unit: mm):



Pallet

Open pore dimension of pallet

Fig.1-5 Operating Panel Outline and Mounting Dimension

1.8 Braking Resistor Lectotype

Inverter model	Braking unit	Braking resistor unit		Braking torque%	
		Braking resistor	Qty.		
AD300-T42R2GB/4R0PB	Built-in as standad	500W	200Ω	1	135
AD300-T44R0GB/5R5PB		500W	200Ω	1	135
AD300-T45R5GB/7R5PB		500W	100Ω	1	135
AD300-T47R5GB/011PB		800W	75Ω	1	130
AD300-T4011GB/015PB		1000W	50Ω	1	135
AD300-T4015GB/018PB		1500W	40Ω	1	125
AD300-T4018G/022P	Need external	4000W	30Ω	1	125
AD300-T4022G/030P		4000W	30Ω	1	125
AD300-T4030G/037P		6000W	20Ω	1	125
AD300-T4037G/045P		9000W	16Ω	1	125
AD300-T4045G/055P		9000W	13.6Ω	1	125
AD300-T4055G/075P		6000W	20Ω	2	135
AD300-T4075G/090P		9000W	13.6Ω	2	145
AD300-T4090G/110P		6000W	20Ω	3	130
AD300-T4110G/132P		6000W	20Ω	3	130
AD300-T4132G/160P		6000W	20Ω	4	130
AD300-T4160G/200P		9000W	13.6Ω	4	130
AD300-T4200G/220P		9000W	13.6Ω	5	130
AD300-T4220G/250P		9000W	13.6Ω	5	130
AD300-T4250G/280P		9000W	13.6Ω	5	130
AD300-T4280G/315P		9000W	13.6Ω	6	130
AD300-T4315G/355P		9000W	13.6Ω	6	130
AD300-T4355G/400P		4000W	3Ω	2	130
AD300-T4400G/450P		4000W	3Ω	2	130
AD300-T4450G/500P		6000W	2Ω	2	130
AD300-T4500G/560P		6000W	2Ω	2	130

Note :

The connection mode for multiple braking resistors is parallel connection. For example, the inverter of AD300-T4055G/075P, the braking resistor lectotype: it is suggest to select two 6000W 20Ωbraking resistor parallel connection, amount to braking resistor is 12000W, 10Ω.

Chapter 2 Inverter Installation

2.1 Environment for Product Installation

- Avoid installing the product in the sites with oil mist, metal powder and dust.
- Avoid installing the product in the sites with hazardous gas and liquid, and corrosive, combustible and explosive gas.
- Avoid installing the products in salty sites.
- Do not install the product in the sites with direct sunlight.
- Do not mount the product on the combustible materials, such as wood.
- Keep the drilling scraps from falling into the inside of inverter during the installation.
- Mount the product vertically in the electric control cabinet, mount the cooling fan or air conditioner to prevent the ambient temperature from rising to above 40 °C.
- For the sites with adverse environment, it is recommended to mount the inverter Radiator heatsink outside the cabinet.

2.2 Mounting Direction and Space

In order not to reduce the inverter cooling effect, the inverter must be mounted vertically, and certain space must be maintained, as shown in Fig. 2-1

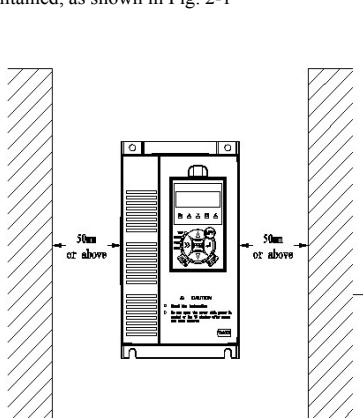

Fig.2-1 Mounting Direction and Space

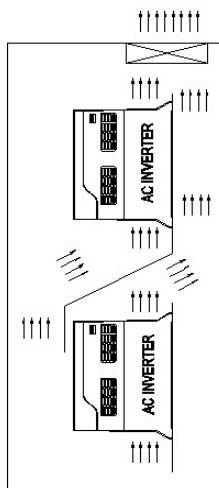

Fig.2-2 Installation Diagram of Upper and Down



Note :

When installing the upper and lower parts of the inverter, the insulating splitter is required.

2.3 Removal and Mounting of Operation Panel and Cover

2.3.1 Removal and Mounting of Operation Panel

◆ Removal of operation panel

As shown in Fig. 2-3, the grab on the operation panel forcefully in direction 1, and then lift the panel body in direction 2.

◆ Mounting of operation panel

As shown in Fig.2-4, align with the lower clamping position of the operation panel in direction 1, until the “crack” sound is heard.

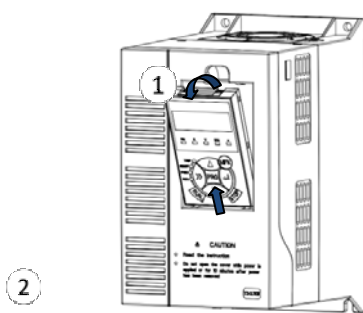

Fig.2-3 Removal of operation panel

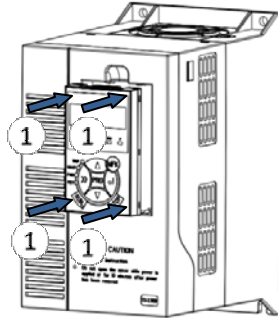

Fig.2-4 Mounting of operation panel

2.3.2 Removal and Mounting of Covers of Inverter with Plastic Enclosure

◆ Removal of cover

Press the left and right sides of the cover forcefully in direction 1 and at the same time lift the cover in direction 2, as shown in Fig. 2-5.

◆ Mounting of cover

After the wiring of main circuit terminals and control circuit terminals, insert the upper claw grab of the upper cover into the groove of the inverter body, as shown in position 1 in Fig.2-6, and then press the lower part of the upper cover in direction 2 as shown in Fig.2-6, until the “crack” sound is heard.

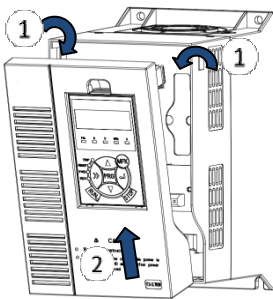

Fig.2-5 Removal of cover

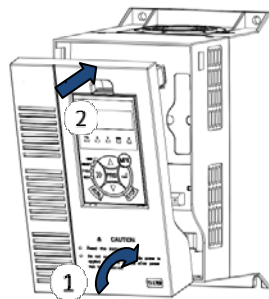

Fig.2-6 Mounting of cover

Chapter 3 Wiring of Inverter

3.1 Connection of the Product and Peripheral Devices

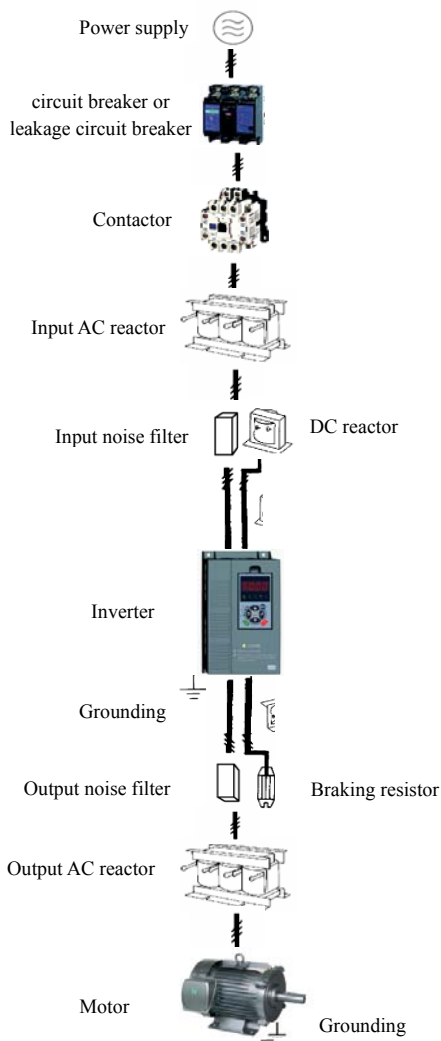

Fig.3-1 Connection diagram of the product and peripheral devices

3.2 Description of Peripheral Devices for Main Circuit

Circuit breaker	The capacity of the circuit breaker shall be 1.5 ~ 2 time of the rated current of the inverter. The time features of the circuit breaker shall fully consider the time features of the inverter overload protection.
Leakage circuit breaker	Because the inverter output is the high-frequency pulse, there will be high-frequency leakage current. Special leakage circuit breaker shall be used when installing leakage circuit breaker at the input end of the inverter. It is suggested that B type leakage circuit breaker be used, and the leakage current value shall be set as 300mA.
Contactors	Frequent open and close of contactor will cause inverter failure, so the highest frequency for the open and close of contactor shall not exceed 10 times/min. When braking resistor is used, to void the over temperature damage of the braking resistor, thermal protection relay with braking resistor over temperature detection shall be installed to disconnect the contactor at the contact control power side of the thermal protection relay.
Input AC reactor or DC reactor	<ol style="list-style-type: none"> 1、 The inverter power supply capacity is more than 600kVA or 10 times of the inverter capacity. 2、 If there is switch type reactive-load compensation capacitor or load with silicon control at the same power node, there will be high peak current flowing into input power circuit, causing the damage of the rectifier components. 3、 When the voltage unbalancedness of the three-phase power supply of the inverter exceeds 3%, the rectifier component will be damaged. 4、 It is required that the input power factor of the inverter shall be higher than 90%. <p>When the above situations occur, install the AC reactor at the input end of the inverter or DC reactor to the DC reactor terminal.</p>
Input noise filter	The noise input from the power end to the inverter and output from the inverter to the power end can be reduced.
Thermal protection relay	Although the inverter has motor overload protection function, when one inverter drives two or more motors or multi-pole motors, to prevent the motor over temperature failure, thermal protection relay shall be installed between the inverter and each motor, and the motor overload protection parameter FC.00 shall be set as “0” (motor protection disabled).
Output noise filter	When the output end of the inverter is connected with noise filter, the conduction and radiation interference can be reduced.
Output AC reactor	When the cable connecting the inverter and the motor is longer than 100m, it is suggested to install AC output reactor to suppress the high-frequency oscillation to avoid the damage to motor insulation, large leakage current and frequent inverter protective action.

3.3 Lectotype of Main Circuit Peripheral Devices

Table 3-1 AD300-T4015GB/018PB and below

Inverter type	Circuit breaker (A)	Contacto (A)	R、S、T、P1、(+）、PB、(-)、U、V、W			Grounding terminal PE ⊕		
			Terminal screw	Tightening torque (N·m)	Wire specification (mm ²)	Terminal screw	Tightening torque (N·m)	Wire specification (mm ²)
AD300-T42R2GB/4R0PB	16	10	M4	1.2~1.5	2.5	M4	1.2~1.5	2.5
AD300-T44R0GB/5R5PB	25	16	M4	1.2~1.5	4	M4	1.2~1.5	4
AD300-T45R5GB/7R5PB	32	25	M4	1.2~1.5	6	M4	1.2~1.5	6
AD300-T47R5GB/011PB	40	32	M4	1.2~1.5	6	M4	1.2~1.5	6
AD300-T4011GB/015PB	63	40	M5	2.5~3	6	M5	2.5~3	6
AD300-T4015GB/018PB	63	63	M5	2.5~3	6	M5	2.5~3	6

Table 3-2 AD300-T4018G/022P and above type

Inverter type	Circuit breaker (A)	Contacto (A)	R、S、T、P1、(+）、(-)、U、V、W			Grounding terminal PE ⊕		
			Terminal screw	Tightening torque (N·m)	Wire specification	Terminal screw	Tightening torque	Terminal screw
AD300-T4018G/022P	100	63	M6	4~6	10	M6	4~6	10
AD300-T4022G/030P	100	100	M6	4~6	16	M6	4~6	16
AD300-T4030G/037P	125	100	M6	4~6	25	M6	4~6	16
AD300-T4037G/045P	160	100	M8	10~12	25	M8	10~12	16
AD300-T4045G/055P	200	125	M8	10~12	35	M8	10~12	16
AD300-T4055G/075P	200	170	M10	20~25	50	M8	10~12	25
AD300-T4075G/090P	250	230	M10	20~25	60	M8	10~12	35
AD300-T4090G/110P	315	250	M10	20~25	70	M8	10~12	35
AD300-T4110G/132P	350	330	M10	20~25	100	M8	10~12	50
AD300-T4132G/160P	400	330	M12	40~45	150	M10	20~25	75
AD300-T4160G/200P	500	400	M12	40~45	185	M10	20~25	50×2
AD300-T4200G/220P	630	500	M12	40~45	240	M10	20~25	60×2
AD300-T4220G/250P	800	630	M12	40~45	150×2	M10	20~25	75×2
AD300-T4250G/280P	1000	630	M12	40~45	150×2	M10	20~25	100×2
AD300-T4280G/315P	1000	800	M12	40~45	185×2	M10	20~25	125×2
AD300-T4315G/355P	1200	800	M12	40~45	240×2	M10	20~25	150×2
AD300-T4355G/400P	1280	960	M16	100~120	240×2	M12	40~45	185×2
AD300-T4400G/450P	1380	1035	M16	100~120	185×3	M12	40~45	185×2
AD300-T4450G/500P	1450	1150	M16	100~120	185×3	M12	40~45	240×2
AD300-T4500G/560P	1720	1290	M16	100~120	185×3	M12	40~45	240×2

3.4 Terminal Configuration Of Main Circuit

3.4.1 AD300–T42R2GB/4R0PB–AD300–T4015GB/018PB

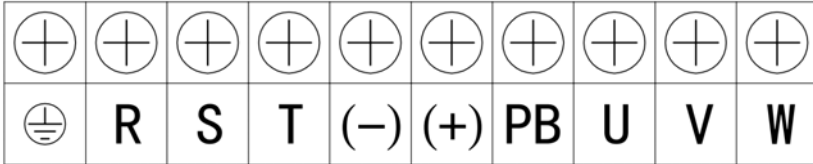

Fig.3-2 3-Phase 400V input 2R2GB/4R0PB–015GB/018PB Main Circuit Connecting terminal

Terminal symbol	Terminal name and function description
	Grounding terminal PE
R、 S、 T	Three-phase AC input terminal
(-)、 (+)	DC power input terminal
(+)、 PB	Connecting terminal of braking resistor
U、 V、 W	Three-phase AC output terminal

3.4.2 AD300–T4018G/022P–AD300–T4110G/132P

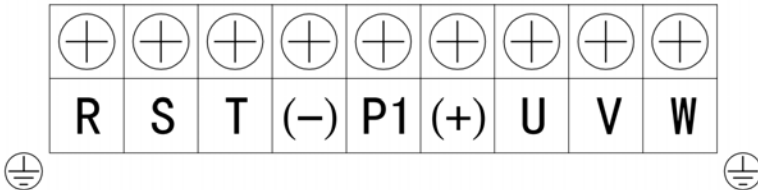

Fig.3-3 3-Phase 400V input 018G/022P–110G/132P Main Circuit Connecting terminal

Terminal description

Terminal symbol	Terminal name and function description
	Grounding terminal PE
R、 S、 T	Three-phase AC input terminal
(-)、 (+)	DC power input terminal
P1、 (+)	DC reactor connecting terminal, short circuited with copper bus upon delivery
U、 V、 W	Three-phase AC output terminal

3.4.3 AD300–T4132G/160P~AD300–T4315G/355P

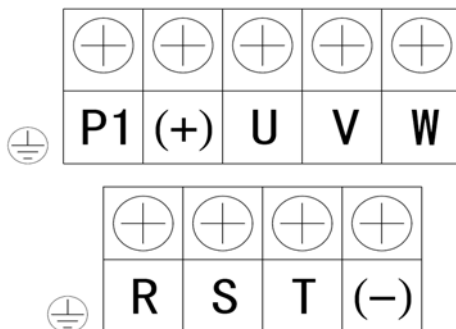

Fig.3-4 3-Phase 400V input 160G/200P~315G/355P Main Circuit Connecting terminal

Terminal description

Terminal symbol	Terminal name and function description
	Grounding terminal PE
R、 S、 T	Three-phase AC input terminal
(-)、 (+)	DC power input terminal
P1、 (+)	DC reactor connecting terminal, short circuited with copper bus upon delivery
U、 V、 W	Three-phase AC output terminal

3.5 Attention for Main Circuit Wiring

3.5.1 Power Supply Wiring

- ◆ It is forbidden to connect the power cable to the inverter output terminal, otherwise, the internal components of the inverter will be damaged.
- ◆ To facilitate the input side over current protection and power failure maintenance, the inverter shall connect to the power supply through the circuit breaker or leakage circuit breaker and contactor.
- ◆ Please confirm that the power supply phases, rated voltage are consistent with that of the nameplate, otherwise, the inverter may be damaged.

3.5.2 Motor Wiring

- ◆ It is forbidden to short circuit or ground the inverter output terminal, otherwise the internal components of the inverter will be damaged.
- ◆ Avoid short circuit the output cable and the inverter enclosure, otherwise there exists the danger of electric shock.
- ◆ It is forbidden to connect the output terminal of the inverter to the capacitor or LC/RC noise filter with phase lead, otherwise, the internal components of the inverter may be damaged.
- ◆ When contactor is installed between the inverter and the motor, it is forbidden to switch on/off the

- ◆ contactor during the running of the inverter, otherwise, there will be large current flowing into the inverter, triggering the inverter protection action.
- ◆ Length of cable between the inverter and motor

If the cable between the inverter and the motor is too long, the higher harmonic leakage current of the output end will cause adverse impact on the inverter and the peripheral devices. It is suggested that when the motor cable is longer than 100m, output AC reactor be installed. Refer to the following table for the carrier frequency setting.

Length of cable between the inverter and motor	Less than 50 m	Less than 100 m	More than 100 m
Carrier frequency (F0.15)	Less than 10kHz	Less than 6kHz	Less than 4kHz

3.5.3 Grounding Wiring

- ◆ The inverter will produce leakage current. The higher the carrier frequency is, the larger the leakage current will be. The leakage current of the inverter system is more than 3.5mA, and the specific value of the leakage current is determined by the use conditions. To ensure the safety, the inverter and the motor must be grounded.
- ◆ The grounding resistance shall be less than 10ohm. For the grounding wire diameter requirement, refer to 3.3 lectotype of main circuit peripheral devices.
- ◆ Do not share grounding wire with the welding machine and other power equipment.
- ◆ In the applications with more than 2 inverters, keep the grounding wire from forming a loop.

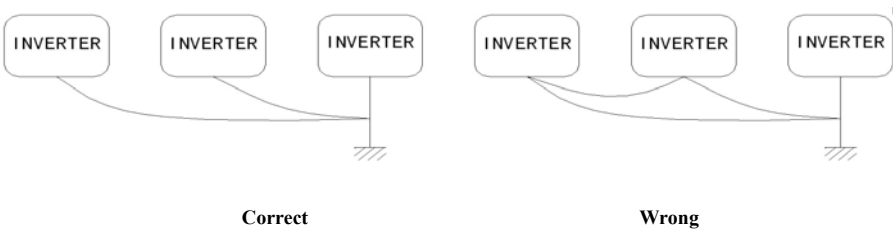

Fig.3-5 Grounding Wiring

3.5.4 Countermeasures for Conduction and Radiation Interference

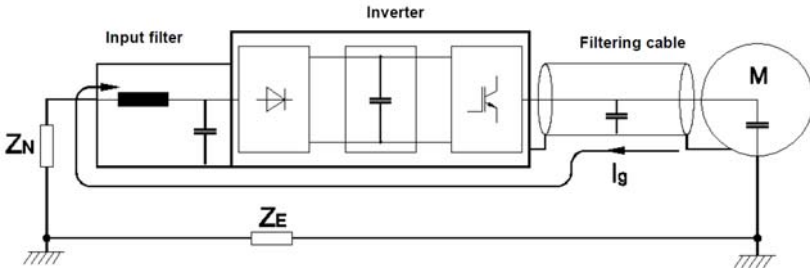

Fig.3-6 Countermeasures for Conduction and Radiation Interference

- ◆ When the input noise filter is installed, the wire connecting the filter to the inverter input power end shall
- ◆ be as short as possible.
- ◆ The filter enclosure and mounting cabinet shall be reliably connected in large area to reduce the back
- ◆ flow impedance of the noise current I_g .
- ◆ The wire connecting the inverter and the motor shall be as short as possible. The motor cable adopts 4-core cable, with the grounding end grounded at the inverter side, the other end connected to the motor enclosure. The motor cable shall be sleeved into the metal tube.
- ◆ The input power wire and output motor wire shall be kept away from each other as long as possible.
- ◆ The equipment and signal cables vulnerable to influence shall be kept far away from the inverter.
- ◆ Key signal cables shall adopt shielding cable. It is suggested that the shielding layer shall be grounded with 360-degree grounding method and sleeved into the metal tube. The signal cable shall be kept far away from the inverter input wire and output motor wire. If the signal cable must cross the input wire and output motor wire, they shall be kept orthogonal.
- ◆ When analog voltage and current signals are adopted for remote frequency setting, twinning shielding cable shall be used. The shielding layer shall be connected to the grounding terminal PE of the inverter, and the signal cable shall be no longer than 50m.
- ◆ The wires of the control circuit terminals RA/RB/RC and other control circuit terminals shall be separately routed.
- ◆ It is forbidden to short circuit the shielding layer and other signal cables or equipment.

3.6 Terminal Wiring

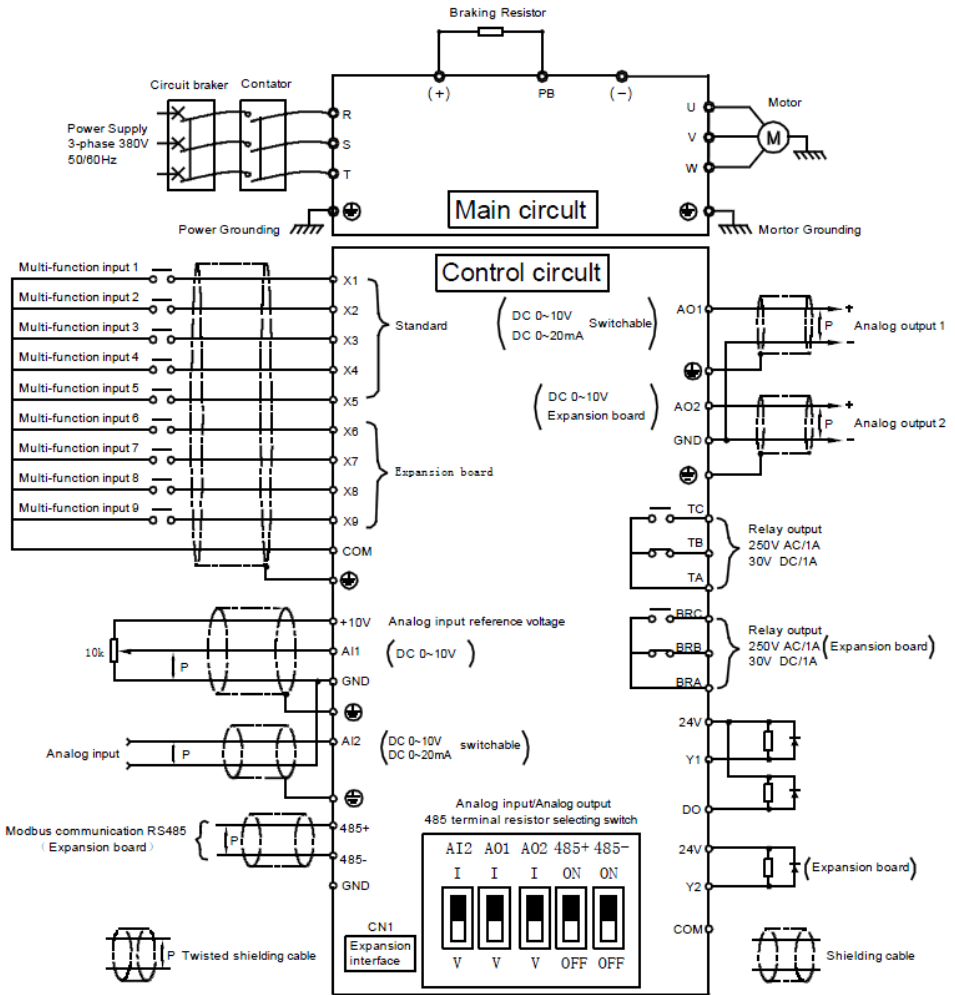

Fig.3-7 Terminal Wiring (Take AD300-T4015G/018P and under type as example)

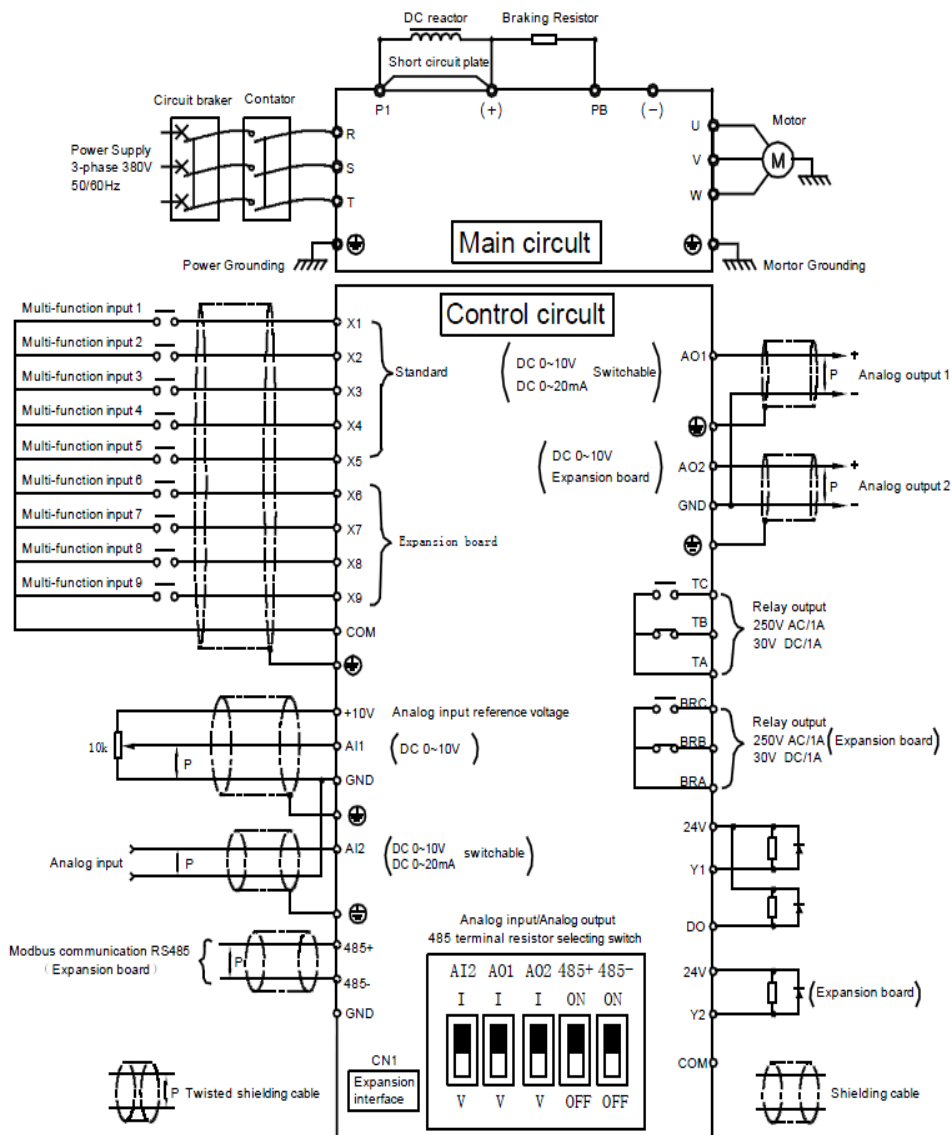

Fig.3-8 Terminal Wiring (type AD300-T4018G/022P and above type as example)

3.7 Functions of Control Circuit Terminals

3.7.1 Standard Configuration Control Circuit Terminals

Type	Terminal symbol	Terminal function description	Technical specification
Digital input	X1~X3	Multi-functional input terminals 1~3	Optical-isolator input Frequency range: 0~200Hz Voltage range: 0~24V
	X4、X5	Multi-functional input or pulse input 4、5	Multi-functional input: same as X1~X3 Pulse input: 0.1Hz~50kHz Voltage range: 0~24V
	COM	Common grounding of multi-functional input terminal	Internal isolated with GND
Digital output	24V	24V	24V±5% , Internal isolated with GND Maximum load :200mA, with overload and short circuit protection
	Y1	Open collector output 1	Optical-isolator output maximum sink current: 50mA Output Voltage range: 0~24V
	DO	Open collector or pulse output	Pulse input: 0~50kHz Open collector same as Y1
	COM	Open collector output common end	Internal isolated with GND
Analog input	10V	Analog input reference voltage	open circuit output voltage come to 11V.Internal isolated with com. Maximum load 30mA, with overload and short circuit
	AI1	Analog input channel 1	Input Voltage range: 0~10V Input impedance: 100kΩ
	AI2	Analog input channel 2	Input Voltage range: 0~10V Input impedance: 100kΩ Input current range: 0~30mA Current Input impedance: 500Ω, 0~20mA or 0~10V analog input can be selected through DIP switch SW1
	GND	Analog grounding	Internal isolated with COM
Analog output	AO1	Analog output 1	0 ~ 20mA : allowable output impedance 200~500Ω 0 ~ 10V : allowable output impedance ≥10kΩ. with short circuit protection function, 0~20mA or 0~10V analog output can be selected through DIP switch SW2
	GND	Analog grounding	Internal isolated with COM
Relay output	TA/TB/TC	Relay output 1	TA—TB: Normally closed TA—TC: Normally open Contact capacity: 250VAC/1A, 30VDC/1A

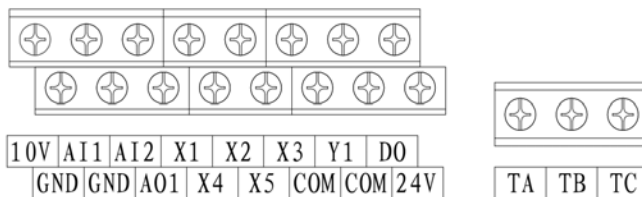

Fig.3-9 Arrangement of Control Circuit Terminals

3.7.2 expanded Control Circuit Terminals

Type	Terminal symbol	Terminal function description	Technical specification
Digital input	X6~X9	Multi-functional input terminals 6~9	Optical-isolator input Frequency range: 0~200Hz Voltage range: 0~24V
	COM	Multi-functional input common end	Internal isolated with GND
Digital output	24V	24V	24V±5%, Internal isolated with GND Maximum load :200mA, with overload and short circuit protection
	Y2	Open collector output 2	Optical-isolator output maximum sink current: 50mA Output Voltage range: 0~24V
	COM	Open collector output common end	Internal isolated with GND
Analog input	AO2	Analog output 2	0~10V : allowable output impedance ≥10kΩ with short circuit protection function,
	GND	Analog grounding	Internal isolated with COM
Relay output	BRA/BRB/BRC	Relay output 2	TA—TB: Normally closed TA—TC: Normally open Contact capacity : 250VAC/1A , 30VDC/1A
Terminal 485	485+	Positive end of 485 differential signal	Rate: 4800/9600/19200/38400bps Up to 127 sets of equipment can be paralleled. Maximum distance: 500m (adopt standard twisted shielding cable)
	485-	Negative end of 485 differential signal	
	GND	Shielding grounding of 485 communication	Internal isolated with COM

Note : Functions of expanded Control Circuit Terminals according to concrete expansion card.

3.7.3 Control Circuit Connection

- X1~X5 Multi-function input terminal , the external controller adopts Dry contacts wiring mode

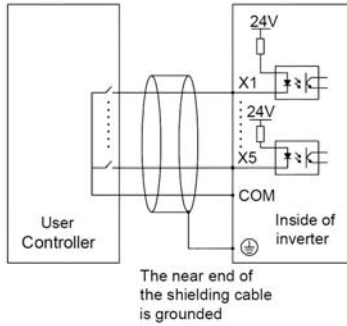

Fig.3-10 Control Circuit Connection specification

- X1~X5 Multi-function input terminal , the external controller adopts NPN sink current wiring mode.

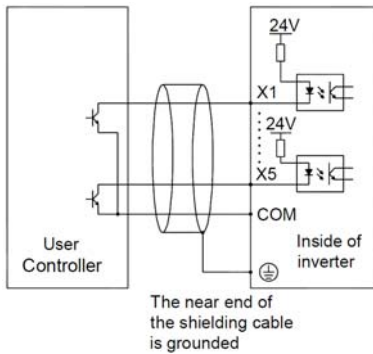

Fig.3-11 NPN common emitter wiring mode

- Y1/Y2、DO:the multi-functional output terminals adopts internal +24V power supply of the inverter wiring mode.

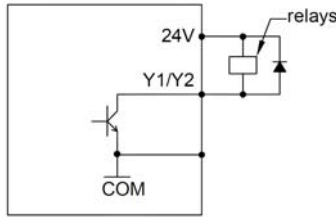

Fig.3-12 wiring mode of internal +24V power supply

- Y1/Y2、DO the multi-functional output terminals adopts external power supply wiring mode

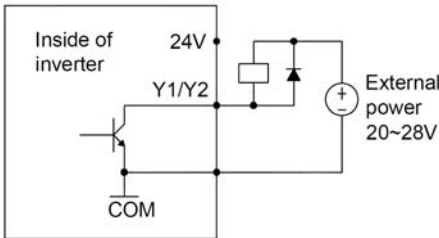
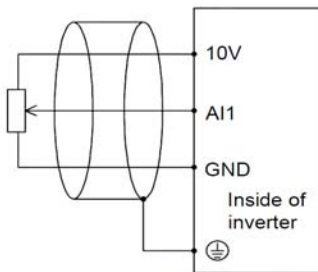

Fig.3-13 wiring mode of external power supply wiring mode

- Wiring mode of analog input terminal



The near end of the shielding cable is grounded

Fig.3-14 Wiring mode of analog input terminal

Keyboard Interface

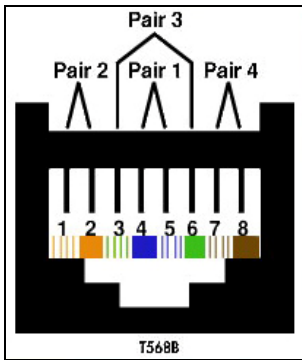

Fig.3-15 T568B standard

Number	Corresponding
1	White/Orange
2	Orange
3	White/Green
4	Blue
5	White/Blue
6	Green
7	White/Brown
8	Brown

Table 3-3 T568B standard

The cables connecting keyboard and control board use standard super-five-class network cable. RJ-45 Interface uses through-line method, namely both sides are connected according to EIA/TIA568B standard. You can make the cable by yourself if you need, May also purchase in the market condition the general mesh wire to use in operating kneading board's connection

3.8 Control board schematic drawing

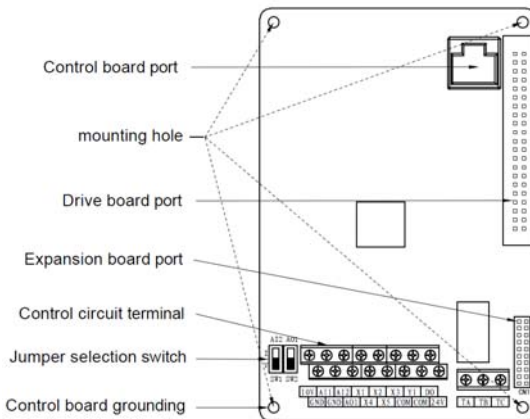

Fig.3-16 Control board schematic drawing

3.9 control circuit Periphery component shaping

Terminal serial number	Terminal screw	Tightening torque (N·m)	Wire specification mm ²	Type of Wire
10V、AI1、AI2、AO1、GND	M3	0.5~0.6	0.75	Twisted pair line Shielded cable
24V、X1、X2、X3、X4、X5、COM、Y1、DO、COM、TA、TB、TC	M3	0.5~0.6	0.75	Shielded cable

3.10 code switch function explanation

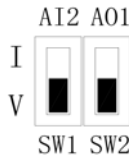

Fig.3-17 code switch function explanation

name	function	Default
AI2	I is current input (0~20mA), V is voltage input (0~10V)	0~10V
AO1	I is current output (0~20mA), V is voltage output (0~10V)	0~10V

Chapter 4 Operation and Display

4.1 Introduction to Operation and Display Interface

The keyboard of AD300 series inverters is the main unit of accepting order, displaying and modifying parameters. The two kinds of keyboards designed for these series inverters are LED keyboard and LCD keyboard respectively. The LED keyboard is the standard fitting, and the LED keyboard is options for special use. For the convenience of introducing, we just introduce the LED keyboard for the different dimensions and operation. The keyboard figure described Fig.4-1.

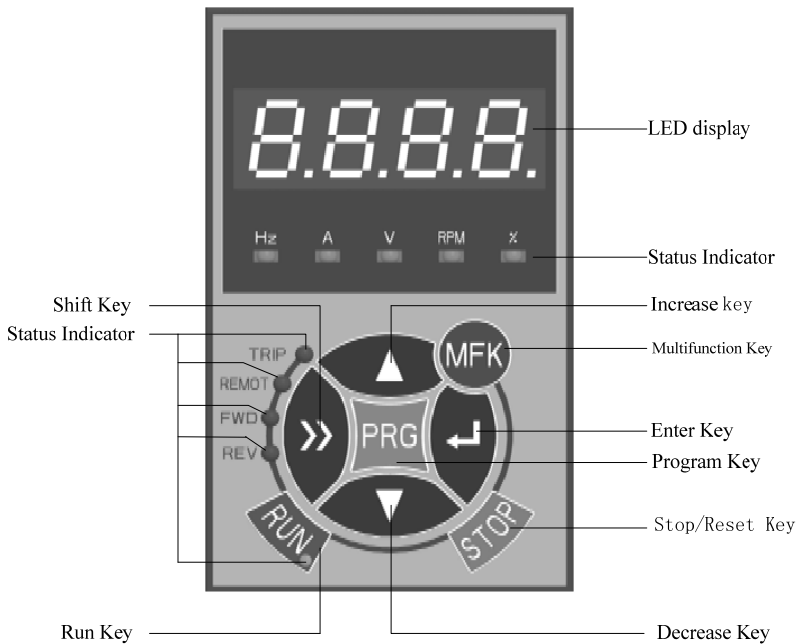

Fig.4-1 Operation Panel Diagram

4.1.1 Keyboard button description

Table 4-1 Keyboard button description

Button	Name	Function
PRG	Programming key	Entry and exit of primary menu, deletion of shortcut parameter
ENTER	Confirmation key	Enter the menu interfaces level by level, and confirm the set parameters.
∧	Increase key	Increase of the data or function code
∨	Decrease key	Decrease of the data or function code
>>	Shift key	Select the displayed parameters in turn on the stop display interface and running display interface, and select the modification digit of parameters when modifying parameters.
RUN	Running key	It is used to start the running of the inverter under keyboard control mode.
STOP	Stop/reset	Press this button to stop the running in the running status and reset the operation in the fault alarm status. This button characteristics are limited by the function code FE.02.
MFK	Multi-function selection key	This button restricted by FE.01 code. 0: MFK inactive 1: JOG running 2: Switching between forward rotation and reverse rotation 3: UP/DOWN clear 4: Switching between operation panel command channel and remote command channel (terminal command channel or serial port communication command channel)

4.1.2 Descriptions of Indicators

Table 4-2 Descriptions of Indicators

Symbol of Indicator	Meanings
Status Indicator	RUN On: Inverter is running Off: Inverter has stopped
	FWD On: Inverter is running forward steadily Off: Inverter is running reverse or stop Flash: Speed up or speed down forward
	REV On: Inverter is running reverse steadily Off: Inverter is running forward or stop Flash: Speed up or speed down reverse
	TRIP Off: Inverter is at normal state Flash: Inverter is at abnormal state
	REMOT Off: Inverter is controlled by the keyboard On: Inverter is controlled by the terminals Flash: Inverter is controlled by serial communication.

Symbol of Indicator		Meanings
Unit Indicator	Hz	On: Current display parameter is running frequency Flash: Current display parameter is setting frequency
	A	On: Current display parameter is current
	V	On: Current display parameter is voltage
	RPM	On: Current display parameter is running motor speed Flash: Current display parameter is setting motor speed
	%	On: Current display parameter is % (running) Flash: Current display parameter is % (setting)
	Hz+A	On: Current display parameter is PID setting Flash: Current display parameter is PID feedback

4.1.3 Digital display zone

Four-digit LED display, able to display setup frequency, output frequency, various monitoring data and alarm code.

4.2 Description of Function Code Viewing and Modification Methods

The operation panel of the AD300 inverter adopts three-level menu structure to carry out operations such as parameter setting. The three-level menu is:

1. function parameter set (level 1 menu)
2. Function code (level 2 menu)
3. Function code setup value (level 3 menu)

Caution: When operating on level 3 menu, press PRG key or ENTER key to return to level 2 menu. The difference between PRG key and ENTER key is described as follows: Pressing ENTER KEY will save the setup parameter and return to the level 2 menu and then automatically shift to the next function code, while pressing PRG key will directly return to level 2 menu without saving the parameter, and it will return to the current function code.

Example: Modify the function code F9.01 from 10.00Hz to 20.00Hz. (The Bigger-type work indicates the flashing bit.), refer to Fig.4-2 for the operation procedure.

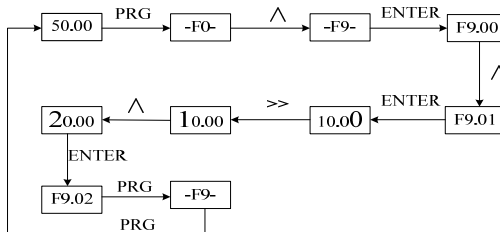

Fig.4-3 Example of parameter editing operation

In level 3 menu, if the parameter has no flashing bit, it indicates that the function code cannot be modified. The possible reasons include:

- 1) The function code is an unchangeable parameter, such as actual detection parameter, running record parameter, etc.

2) The function code cannot be modified in running status. It can be modified only after the unit is stopped.

4.3 Display status of keyboard

The display status of AD300 series inverters are the stopped state parameter display, the running status parameter display, the function code edition display and the fault warning condition display respectively.

1. The stop status parameter display

The keyboard displays the stop state parameter display, press “>>” to display circularly different the stop state parameter when the inverter enters into this state.

2. The running state parameter display

The keyboard displays the running state parameter display, press “>>” to display circularly different running state parameter when the inverter is running.

3. Fault and warning state

If the inverter has checked out a warning signal, it will come into warning state and show the warning code flickeringly. If the warning signal disappeared, the warning code will automatically disappear.

If the inverter has checked out an error, it will come into fault state and show the fault code steadily. And the indicator TRIP will light up. By depressing the “>>” key, user can view the parameters value of stop state; If you want to see the details of fault information, depress the “PRG” key, the keyboard will go to programming state, to see the details, please see the parameter values of group FF.

To reset the inverter, depress the “STOP” key or control terminals or serial communication. If the fault signal is still exist, the keyboard will keep the fault code displaying and the indicator TRIP lighting.

4. the function code edition state

When in the stop, running fault or warning state, depress the “PRG” key, the inverter will come into programming state. Depress the “ENTER” key, the display menu will be changed gradually. When in function parameter value menu, depress the “ENTER” key can save the value of the parameter; Depress the “PRG” key will exit from one menu to another.

4.4 Password Setting

The inverter provides user password protection function. When FP.00 is set to non-zero value, it indicates the user password, and the password protection turns valid after exiting the function code editing status. When pressing PRG key again, “0000” will be displayed, and common menu cannot be entered until user password is input correctly.

To cancel the password protection function, enter with password and set FP.00 to “0”.

Chapter 5 List of Parameters

Attention:

“○” means that the parameters can be changed during inverter running and stopping state;

“×” means that the parameters cannot be changed during running;

“*” means that the actually measured value or fixed parameters cannot be changed;

“.” means that the parameter is set by the manufacturer and cannot be changed by the user

Group F0 Basic function

Function Code	Function code name	LED display	Setting range	Factory default value	Property
F0.00	Model display	Model display	0~1	Model dependent	-
F0.01	Control operation mode	Control operation mode	0: Vector control 1 without encoder speed feedback 1: Vector control 2 without encoder speed feedback 2: Vector control with encoder speed feedback 3: V/F control	0	×
F0.02	Run command source selection	Run command source selection	0: Operation panel running command channel 1: Terminal command channel 2: serial port command channel	0	○
F0.03	Frequency setting 1	Frequency setting1	0: Digital setup UP and DOWN adjustment 1: AI1 2: AI2 3: PULSE setup 4: Communication setup 5:MS (Multi-step) Speed 6: PLC 7: PID 8:keyboard potentiometer	0	○
F0.04	Frequency setting 2	Frequency setting2	1: AI1 2: AI2 3: PULSE setup 4: Communication setup 5:MS (Multi-step) Speed 6: Reserved 7: Reserved 8:keyboard potentiometer	1	○

Function Code	Function code name	LED display	Setting range	Factory default value	Property
F0.05	Frequency setting selection	Frequency setting selection	0:Frequency setting1 1:Frequency setting2 2: Frequency setting1+ Frequency setting2 3:Switching between Frequency setting 1 and Frequency setting 2 4: Switching between (Frequency setting1+ Frequency setting2) and Frequency setting1 5:MIN(Frequency setting1, Frequency setting2) 6:MAX(Frequency setting1, Frequency setting2)	0	○
F0.06	UP/DOWN Preset frequency	UP/DOWN Preset frequency	0~Max frequency	50.00Hz	○
F0.07	Terminal UP/DOWN rate	Terminal UP/DOWN rate	0.01~50.00Hz/s	1.00Hz/s	○
F0.08	UP/DOWN keyboard and terminal select	UP/DOWN keyboard and terminal select	0:Active keyboard and terminal UP/DOWN 1:Active only in keyboard UP/DOWN 2: Active only in Terminal UP/DOWN	1	○
F0.09	UP/DOWN Power failure record selection	UP/DOWN Power failure record selection	0: Power failure record 1: Power failure non-record 2:Stop non-record	0	○
F0.10	Basic frequency	Basic frequency	0.10~300.0Hz	50.00Hz	×
F0.11	Max frequency	Max frequency	MAX[50.00Hz, Frequency upper limit, Reference frequency]~600.0Hz	50.00Hz	×
F0.12	Frequency upper limit	Frequency upper limit	Frequency lower limit-max frequency	50.00Hz	×
F0.13	Frequency lower limit	Frequency lower limit	0.00~Frequency lower limit	0.00Hz	×
F0.14	Max output voltage	Max output voltage	110~440V	380V	×
F0.15	Carrier frequency	Carrier frequency	1.0~16.0K	Model dependent	○
F0.16	Carrier frequency auto-adjustment selection	Carrier frequency auto-adjustment selection	0: adjustment 1: non- adjustment	0	○
F0.17	Keyboard direction setting selection	Keyboard direction setting selection	0: Forward 1: Reverse	0	○
F0.18	Wiring direction of motor	Wiring direction of motor	0: Positive sequence 1: Antitone sequence	0	×
F0.19	Acceleration time1	Acceleration time1	0.1~3600s	6.0/20.0s	○
F0.20	Deceleration time1	Deceleration time1	0.1~3600s	6.0/20.0s	○

Group F1: Start and stop control

Function Code	Function code name	LED display	Setting range	Factory default value	Property
F1.00	Start mode	Start mode	0: Start directly 1: DC brake first and then start at start frequency 2: Speed tracking and start	0	○
F1.01	Start frequency	Start frequency	0.10~60.00Hz	0.50Hz	○
F1.02	Start frequency holding time	Start holding time	0.0~10.0s	0.0s	○
F1.03	DC injection braking current at start	Brake current at start	Type G: 0.0~100.0% of inverter rated current Type P: 0.0~80.0% of inverter rated current	0.0%	○
F1.04	DC injection braking time before start	Brake time at start	0.0~30.0s	0.0s	○
F1.05	Acceleration /Deceleration mode	Acceleration /Deceleration mode	0: Linear 1: S-curve	0	○
F1.06	Time of S-curve initial	Time of S-curve initial	10.0~50.0% (Acceleration/Deceleration time) F1.06+F1.07≤90%	30.0%	○
F1.07	Time of S-curve rising	Time of S-curve rising	10.0~80.0% (Acceleration/Deceleration time) F1.06+F1.07≤90%	40.0%	○
F1.08	Stop mode	Stop mode	0: Deceleration to stop 1: Coast to stop 2: Deceleration +DC braking	0	×
F1.09	DC brake beginning frequency at stop	Brake frequency at stop	0.00~600.0Hz	0.00Hz	○
F1.10	DC brake waiting time at stop	DC brake waiting time at stop	0.00~10.00s	0.00s	○
F1.11	DC brake current at stop	DC brake current at stop	Type G: 0.0~100.0% of inverter rated current Type P: 0.0~80.0% of inverter rated current	0.0%	○
F1.12	DC brake time at stop	DC brake time at stop	0.0~30.0s	0.0s	○
F1.13	Energy consumption braking selection	Energy consumption braking selection	0: Disabled 1: Enabled	0	○
F1.14	Energy consumption braking unit action voltage	braking unit action voltage	380V: 650~750V 220V: 360~390V	380V: 700V 220V: 380V	○
F1.15	Restart automatically after power resumes normal	Restart automatically after power resumes normal	0: Disable 1: Enable	0	○
F1.16	Waiting time for restart	Waiting time for restart	0.0~3600s	0.0s	○

Group F2: Auxiliary Function

Function Code	Function code name	LED display	Setting range	Factory default value	Property
F2.00	Jog running frequency	Jog running frequency	0.10~50.00Hz	5.00Hz	○
F2.01	Jog Acceleration time	Jog Acceleration time	0.1~3600s	6.0/20.0s	○
F2.02	Jog Deceleration time	Jog Acceleration time	0.1~3600s	6.0/20.0s	○
F2.03	Acceleration time2	Jog Deceleration time	0.1~3600s	20.0s	○
F2.04	Deceleration time2	Acceleration time2	0.1~3600s	20.0s	○
F2.05	Acceleration time3	Deceleration time2	0.1~3600s	20.0s	○
F2.06	Deceleration time3	Acceleration time3	0.1~3600s	20.0s	○
F2.07	Acceleration time4	Deceleration time3	0.1~3600s	20.0s	○
F2.08	Deceleration time4	Acceleration time4	0.1~3600s	20.0s	○
F2.09	Skip frequency 1	Skip frequency 1	0.00~300.0	0.00Hz	×
F2.10	Skip frequency 2	Skip frequency 2	0.00~300.0	0.00Hz	×
F2.11	Skip frequency amplitude	Skip frequency amplitude	0.00~15.00Hz	0.00Hz	×
F2.12	Reverse control	Reverse control	0: Reverse rotation enabled 1: Reverse rotation disable	0	○
F2.13	Forward/ Reverse rotation dead-zone time	Forward/ Reverse rotation dead-zone time	0.0~3600s	0.0s	○
F2.14	Start frequency lower than frequency lower limit action	Start frequency lower than frequency lower limit action	0: Run with frequency lower limit 1: Zero frequency operation	0	×
F2.15	Running time to action selection	Running time to action selection	0: Continue running 1: Stop	0	×
F2.16	Energy saving control selection	Energy saving control selection	0: Disabled 1: Enabled	0	×
F2.17	AVR Function	AVR Function	0: Disabled 1: Enabled 2: Disabled only at speed-down	2	×
F2.18	Over modulation enabled	Over modulation enabled	0: Enabled 1: Disabled	1	×
F2.19	Droop control	Droop control	0.00~10.00Hz	0.00Hz	○

Function Code	Function code name	LED display	Setting range	Factory default value	Property
F2.20	Fan control mode	Fan control mode	0: Auto mode 1: Always Running	0	×
F2.21	Instant power off procession	Instant power off procession	0: Disabled 1: down frequency 2: Stop directly	0	○
F2.22	Instant power off frequency down point	Instant power off frequency down point	210~600V	380V: 420V 220V: 230V	○
F2.23	Instant power off frequency down rate	Instant power off frequency down rate	0.00~max frequency /s	10.00Hz/s	○
F2.24	Motor speed display ratio	Motor speed display ratio	0.00~500.0%	100.0%	○
F2.25	UP/DOWN descend to negtive	UP/DOWN descend to negtive	0: Enabled 1: Disable	1	○

Group F3: Vector Control Parameters

Function Code	Function code name	LED display	Setting range	Factory default value	Property
F3.00	Speed loop proportional gain 1	Speed loop proportional gain 1	0.1~9.9	1.0	○
F3.01	Speed loop integral time 1	Speed loop integral time 1	0.01~10.00s	0.3s	○
F3.02	Switching frequency 1	Switching Frequency 1	0.0~60.00Hz	5.00Hz	○
F3.03	Speed loop proportional gain 2	Speed loop proportional gain 2	0.1~9.9	1.0	○
F3.04	Speed loop integral time 2	Speed loop integral time 2	0.01~10.00s	0.3s	○
F3.05	Switching frequency 2	Switching Frequency 2	0.0~60.00Hz	10.00Hz	○
F3.06	ASR filtering time	ASR filtering time	0~500ms	1ms	○
F3.07	Current loop proportional coefficient	Current loop proportional coefficient	0~2000	500	○
F3.08	Current loop integral coefficient	Current loop integral coefficient	0~6000	500	○
F3.09	Slip compensation coefficient	Slip coefficient	0.0~200.0%	100.0%	○
F3.10	Torque control	Torque control	0:Torque control Disabled 1:Torque digital setting(F3.11) 2:A11 3:A12 4:PULSE 5:serial communication 6:keyboard potentiometer	0	○

AD300 Performance Vector Control /Torque Control Inverter User manual

Function Code	Function code name	LED display	Setting range	Factory default value	Property
F3.11	Torque digital setting	Torque digital setting	0.0~200.0%	50.0%	○
F3.12	Torque control upper speed limit	Torque control speed upper limit	0:digital setting(F3.13) 1:A11 2:A12 3:PULSE 4:Serial communication	0	○
F3.13	upper speed limit setting	upper speed limit setting	0.00~300.0Hz	50.00Hz	○
F3.14	Encoder pulse number	Encoder pulse number	1~9999	1000	○
F3.15	Deceleration ratio between motor and PG	Deceleration ratio between motor and PG	0.010~50.00	1.000	○
F3.16	PG direction selection	PG direction selection	0: Positive 1: Negative	0	○
F3.17	Reserved	Reserved	0.01~600.0s	0.10s	○
F3.18	Reserved	Reserved	0.00~3.00	0.10s	○
F3.19	Reserved	Reserved	0.0~10.0%	0.1%	○
F3.20	Reserved	Reserved	0.0~100.0s	1.0s	○
F3.21	Torque Compensation in constant power zone	Torque Compensation in constant power zone	0:Disable 1:Enable	1	○
F3.22	Torque Compensation coefficient in constant power zone	Torque Compensation coefficient in constant power zone	60.0~300.0%	200.0%	○
F3.23	Reserved	Reserved	0.01~10.00	1.00	○

Group F4 V/F Control Parameters

Function Code	Function code name	LED display	Setting range	Factory default value	Property
F4.00	V/F curve setting	V/F curve setting	0: Straight V/F 1: 2.0 order decreasing torque 2: 1.5 order decreasing torque 3: 1.2 order decreasing torque 4: Multiple-point V/F	0	×
F4.01	V/F frequency point 1	V/F frequency point 1	0.0~F4.03	10.00Hz	×
F4.02	V/F voltage point 1	V/F voltage point 1	0.0~100.0%	20.0%	×

AD300 Performance Vector Control /Torque Control Inverter User manual

Function Code	Function code name	LED display	Setting range	Factory default value	Property
F4.03	V/F frequency point 2	V/F frequency point 2	F4.01~F4.05	25.00Hz	×
F4.04	V/F voltage point 2	V/F voltage point 2	0.0~100.0%	50.0%	×
F4.05	V/F frequency point 3	V/F frequency point 3	F4.03~F0.10	40.00Hz	×
F4.06	V/F voltage point 3	V/F voltage point 3	0~100.0%	80.0%	×
F4.07	Torque boost	Torque boost	0.0%: automatic 0.1~30.0%	0.0%	○
F4.08	Cutoff frequency of torque boost	Cutoff frequency of torque boost	0.00~60.00Hz	50.00Hz	○
F4.09	Slip compensation coefficient	Slip compensation coefficient	0.0~200.0%	0.0%	○
F4.04	V/F voltage point 2	V/F voltage point 2	0.0~100.0%	50.0%	×
F4.10	Slip compensation filtering time	Slip compensation filtering time	0.01~2.55s	0.20s	○
F4.11	Voltage source when V/F control separately	Voltage source when V/F control separately	0: Disabled 1: Digital setting (F4.12) 2: AI1 3: AI2 4: PULSE 5: Serial communication	0	×
F4.12	Voltage digital setting	Voltage digital setting	0V~max output voltage	0V	○
F4.13	Voltage Acceleration/Deceleration time	Voltage Acceleration/Deceleration time	0.0s~1000.0s	0.0s	○

Group F5 Motor Parameters

Function Code	Function code name	LED display	Setting range	Factory default value	Property
F5.00	motor type selection	motor type selection	0: Common asynchronous motor 1: Variable frequency asynchronous motor 2: Permanent magnetic synchronous motor	0	×
F5.01	Motor polarity number	Motor polarity number	2~56	4	×
F5.02	rated power	rated power	0.4~999.9kW	Model dependent	○
F5.03	rated current	rated current	0.1~999.9A	Model dependent	○
F5.04	rated rotation speed	rated rotation speed	0~2400rpm	Model dependent	
F5.05	no-load current I0	no-load current I0	0.1~999.9A	Model dependent	○

Function Code	Function code name	LED display	Setting range	Factory default value	Property
F5.06	Stator resistance R1	Stator resistance R1	0.00%~50.00%	Model dependent	○
F5.07	Leakage Inductive reactance X	Leakage Inductive reactance X	0.00%~50.00%	Model dependent	○
F5.08	Rotor resistance R2	Rotor resistance R2	0.00%~50.00%	Model dependent	○
F5.09	Mutual Inductive reactance Xm	Mutual Inductive reactance Xm	0.0%~200.0%	Model dependent	○
F5.10	Tuning selection	Tuning selection	0: No operation 1: Static tuning 2: Complete tuning	0	×

Group F6 Input terminal

Function Code	Function code name	LED display	Setting range	Factory default value	Property
F6.00	Terminal Command mode	Terminal Command mode	0: Two-wire mode 1 1: Two-wire mode 2 2: Three-wire mode 1 3: Three-wire mode 2	0	×
F6.01	X1 terminal Function selection	X1 terminal selection	0: NULL 1: Forward rotation (FWD) 2: Reverse rotation (REV) 3: RUN 4: FWD/REV running direction 5: HLD self-hold selection 6: Forward rotation Jog (FJOG) 7: Reverse rotation Jog (RJOG) 8: Fault reset (RESET) 9: Frequency source switching 10: Terminal UP 11: Terminal DOWN 12: UP/DOWN setup clear 13: Coast to stop 14: DC injection braking 15: Acceleration/deceleration inactive 16: Inverter running prohibit 17: Multi-step speed terminal 1 18: Multi-step speed terminal 2 19: Multi-step speed terminal 3 20: Multi-step speed terminal 4 21: torque control inactive 22: Acceleration/deceleration time selection terminal 1 23: Acceleration/deceleration time selection terminal 2 24: External interrupt signal normally open input 25: External interrupt signal normally closed input	1	×
F6.02	X2 terminal Function selection	X2 terminal selection		2	×
F6.03	X3 terminal Function selection	X3 terminal selection		8	×
F6.04	X4 terminal Function selection	X4 terminal selection		17	×
F6.05	X5 terminal Function selection	X5 terminal selection		18	×
F6.06	X6 terminal Function selection	X6 terminal selection		0	×
F6.07	X7 terminal Function selection	X7 terminal selection		0	×
F6.08	X8 terminal Function selection	X8 terminal selection		0	×
F6.09	X9 terminal Function selection	X9 terminal selection		0	×

Function Code	Function code name	LED display	Setting range	Factory default value	Prope rty
			26: External fault normally open input 27: External fault normally closed input 28: Running command switching toterminal 29: Running command switching to Keyboard 30: External stop terminal When it is in the keyboard control mode, this terminal can be used to stop, which is similar to STOP key on the keyboard. 31: Reseved 32: PLC status reset 33: Swing frequency pause 34: Swing frequency status reset 35: PID pause 36: PID parameters switching 37: PID action direction reverse terminal If this terminal is enabled, PID action direction is opposite to the direction set in F8.04. 38: Timing drive input 39: Counter trig signal input 40: Counter clear 41: Actual length clear 42~56: Reserved 57: PUL: Pulse input (If have 2 signals input, follow X4) 55: Single-phase speed measuring input (If have 2 signals input, follow X4) 56: Speed measuring input A (only for X4) 57: Speed measuring input B (only for X5)		
F6.10	Analog Nonlinear Selection	Analog Nonlinear Selection	0: none 1: AI1 2: AI2 3: Pulse	0	×
F6.11	AI1 minimum input	AI1 minimum input	0.00~F6.13	0.00V	○
F6.12	AI1 minimum Input corresponding setup	AI1 minimum Input corresponding setup	0.0~200.0%	0.0%	○
F6.13	AI1 maximum input	AI1 maximum input	F6.11~10.00V	10.00V	○
F6.14	AI1 maximum Input corresponding setup	AI1 maximum Input corresponding setup	0.0~200.0%	100.0%	○

Function Code	Function code name	LED display	Setting range	Factory default value	Property
F6.15	AI1 input filter time	AI1 input filter time	0.01~50.00s	0.05s	○
F6.16	AI2 minimum input	AI2 minimum input	0.00~F6.18	0.00V	○
F6.17	AI2 minimum Input corresponding setup	AI2 minimum Input corresponding setup	0.0~200.0%	0.0%	○
F6.18	AI2 maximum input	AI2 maximum input	F6.16~10.00V	10.00V	○
F6.19	AI2 maximum Input corresponding setup	AI2 maximum Input corresponding setup	0.0~200.0%	100.0%	○
F6.20	AI2 input filter time	AI2 input filter time	0.01~50.00s	0.05s	○
F6.21	PULSE input minimum frequency	PULSE input minimum frequency	0.00~F6.23	0.00kHz	○
F6.22	PULSE input Minimum Frequency Corresponding setup	PULSE input Minimum Frequency Corresponding setup	0.0~200.0%	0.0%	○
F6.23	PULSE input maximum frequency	PULSE input maximum frequency	F6.21~50.00kHz	50.00kHz	○
F6.24	PULSE input Maximum Frequency Corresponding setup	PULSE input Maximum Frequency Corresponding setup	0.0~200.0%	100.0%	○
F6.25	Pulse filter time	Pulse filter time	0.01~50.00s	0.05s	○
F6.26	Corresponding setup positive or negative	Corresponding setup positive or negative	0~63	0	○

Group F7 Output terminal

Function Code	Function code name	LED display	Setting range	Factory default value	Property
F7.00	DO terminal output selection	DO terminal output selection	0: NULL 1: Inverter is running 2: Frequency arrival(FAR) 3: Frequency level detection 1 (FDT1) 4: Frequency level detection 2 (FDT2) 5: Frequency detection when speed-up	0	○
F7.01	Y1 terminal output selection	Y1 terminal output selection		1	○
F7.02	Y1 terminal output selection	Y1 terminal output selection		0	○

Function Code	Function code name	LED display	Setting range	Factory default value	Prope rty
F7.03	Relay 1 (TA/TB/TC) output selection	Relay 1 (TA/TB/TC) output selection	6: Frequency detection when speed-down 7: Zero-speed running 8: Zero-speed 9: PLC circulation completion 10: Programming Running steps (only active to DO\Y1\Y2, and need to set F7.00, F7.01, F7.02 the same value as 10) 11: Ready for running 12: Timing arrival 13: counting value arrival 14: Preset operating time arrival 15: Torque arriving detection threshold 16: Inverter fault output 17: Under voltage status output 18: Inverter overload pre-warning 19: Fixed-length arrived, output a high level signals 20: PID Standby 21: AI1>AI2 22: AI1<F7.16 23: AI1>F7.16 24: F7.16<AI1<F7.17 25: Frequency lower limit arrival 26:Auxiliary pump control signal for constant pressure water supply	16	○
F7.04	Relay 2 (BRA/BRB/BRC) output selection	Relay 2 (BRA/BRB/BRC) output selection		0	○
F7.05	Frequency arrival detection width	FAR detection width	0.00~10.00Hz	2.50Hz	○
F7.06	Frequency detection value 1 (FDT1 level)	FDT1 level	0.00~600.0Hz	5.00Hz	○
F7.07	Frequency detection hysteresis1(FDT1-hysteresis)	FDT1 hysteresis	0.00~10.00Hz	1.00Hz	○
F7.08	Frequency detection value 2 (FDT2 level)	FDT2 level	0.00~600.0Hz	25.00Hz	○
F7.09	Frequency detection hysteresis1(FDT2-hysteresis)	FDT2 hysteresis	0.00~10.00Hz	1.00Hz	○
F7.10	Up detection frequency	Up detection frequency	0.00~600.0Hz	50.00Hz	○
F7.11	Down detection frequency	Down detection frequency	0.00~600.0Hz	0.00Hz	○
F7.12	Torque detection reference	Torque detection reference	0.0~200.0%	100.0%	○

Function Code	Function code name	LED display	Setting range	Factory default value	Property
F7.13	Preset Count value	Torque detection reference	0~9999	0	○
F7.14	Preset Timing value	Preset Count value	0.0~6553.0s	0.0s	○
F7.15	Reserved	Reserved	0~65530h	65530h	○
F7.16	AI1 compare threshold 1	AI1 compare threshold 1	0.00~10.00v	0.00v	○
F7.17	AI1 compare threshold 2	AI1 compare threshold 2	0.00~10.00v	0.00v	○
F7.18	Analog compare hysteresis	Analog compare hysteresis	0.00~3.00v	0.20v	○
F7.19	AO1 output selection	AO1 output selection	0: NULL 1: Running frequency(0~max frequency)	1	○
F7.20	AO2 output selection	AO2 output selection	2: Setting frequency(0~max frequency) 3: Output current(0~2* inverter rated current)	0	○
F7.21	DO output selection	DO output selection	4: Output voltage (0~Max Voltage) 5: PID setup (0~10V) 6: PID feedback (0~10V) 7: Adjust signals (5V) 8: Output torque (0~2*motor rated torque) 9: Output power (0~2*Inverter rated power) 10: Bus voltage (0~1000V) 11: 9: AI1 (0~10V) 12: AI2 (0~10V/0~20mA) 13: Pulse input	0	○
F7.22	AO1 output range selection	AO1 output range selection	0: 0~10V/0~20mA 1: 2~10V/4~20mA	0	○
F7.23	AO2 output range selection	AO2 output range selection	0: 0~10V 1: 2~10V	0	○
F7.24	Gain of AO1	Gain of AO1	1~200%	100%	○
F7.25	Gain of AO2	Gain of AO2	1~200%	100%	○
F7.26	Max output frequency of DO	Max output frequency of DO	Min Pulse value output of DO~50.00kHz	50.00kHz	○
F7.27	Min output frequency of DO	Min output frequency of DO	0.00~ Max Pulse value Output of DO	0.00kHz	○
F7.28	Delay time for Auxiliary pump run	Delay time for Auxiliary pump run	0~9999s	0s	○
F7.29	Delay time for Auxiliary pump stop	Delay time for Auxiliary pump stop	0~9999s	0s	○

Group F8 PID Parameters

Function Code	Function code name	LED display	Setting range	Factory default value	Property
F8.00	PID setup selection	PID setup selection	0: PID digital setting (F8.02) 1: AI1 terminal 2: AI2 terminal 3: Pulse input 4: serial communication	0	○
F8.01	PID feedback selection	PID feedback selection	0: AI1 terminal 1: AI2 terminal 2: Pulse input 3: serial communication 4: AI1-AI2 5: AI1+AI2 6: MAX(AI1, AI2) 7: MIN(AI1, AI2)	1	○
F8.02	PID setup	PID setup	0.0~999.9	50.0	○
F8.03	Analog closed loop measuring range	Analog closed loop measuring range	1.0~999.9	100.0	○
F8.04	PID action direction	PID action direction	0: Positive 1: Negative	0	○
F8.05	PID proportional gain 1 (KP1)	PID proportional gain 1 (KP1)	0.1~9.9	1.0	○
F8.06	PID integration time 1	PID integration time 1	0.00~100.0s	10.00s	○
F8.07	PID differential time 1	PID differential time 1	0.00~1.00s	0.00s	○
F8.08	PID proportional gain 2 (KP2)	PID proportional gain 2 (KP2)	0.1~9.9	1.0	○
F8.09	PID integration time 2	PID integration time 2	0.00~100.0s	10.00s	○
F8.10	PID differential time 2	PID differential time 2	0.00~1.00s	0.00s	○
F8.11	PID parameters switching	PID parameters switching	0: No switching, use the first group parameters 1: switching by terminal 2: auto-switching by deviation	0	○
F8.12	Deviation 1 using PID switching	Deviation 1 using PID switching	0.0~999.9	20.0	○
F8.13	Deviation 2 using PID switching	Deviation 2 using PID switching	0.0~999.9	80.0	○
F8.14	PID delay time constant	PID delay time constant	0.00~100.0s	0.00s	○
F8.15	Deviation limit	Deviation limit	0.0~999.9	0.2	○
F8.16	PID output positive limit	PID output positive limit	0.00~300.0Hz	50.00Hz	○
F8.17	PID output negative limit	PID output negative limit	0.00~300.0Hz	0.00Hz	○

Function Code	Function code name	LED display	Setting range	Factory default value	Property
F8.18	PID preset frequency	PID preset frequency	0.00~300.0Hz	0.00Hz	×
F8.19	Hold time of PID preset frequency	Hold time of PID preset frequency	0.0~3600s	0.0s	×
F8.20	Enable dormancy	Enable dormancy	0: Disabled 1: Enabled	0	×
F8.21	Dormancy delay	Dormancy delay	0~2000s	120s	○
F8.22	Dormancy threshold	Dormancy threshold	0.00~300.0Hz	20.00Hz	○
F8.23	Awakening threshold	Awakening threshold	0.0~999.9	5.0	○

Group F9 Multi-step speed and PLC

Function Code	Function code name	LED display	Setting range	Factory default value	Property
F9.00	Multi-step frequency 1	Multi-step frequency 1	0.00~Max frequency	5.00 Hz	○
F9.01	Multi-step frequency 2	Multi-step frequency 2	0.00~Max frequency	10.00 Hz	○
F9.02	Multi-step frequency 3	Multi-step frequency 3	0.00~Max frequency	15.00 Hz	○
F9.03	Multi-step frequency 4	Multi-step frequency 4	0.00~Max frequency	20.00 Hz	○
F9.04	Multi-step frequency 5	Multi-step frequency 5	0.00~Max frequency	30.00 Hz	○
F9.05	Multi-step frequency 6	Multi-step frequency 6	0.00~Max frequency	40.00 Hz	○
F9.06	Multi-step frequency 7	Multi-step frequency 7	0.00~Max frequency	50.00 Hz	○
F9.07	PLC running mode	PLC running mode	0: Single cycle 1 1: Single cycle 2 (holding final value) 2: Continuous operation	2	×
F9.08	PLC restarting mode selection	PLC restarting mode selection	0: Restart from first step 1: Continue from the step where the inverter stops	0	×
F9.09	PLC power failure Recorded selection	PLC power-failure Recorded selection	0: Power failure non-recorded 1: Power failure recorded	0	×
F9.10	Unit of step time	Unit of step time	0: Second 1: Minute	0	×
F9.11	Program running timing T1	Program running timing T1	0.1~3600	20.0	○
F9.12	Program running timing T2	Program running timing T2	0.0~3600	20.0	○
F9.13	Program running timing T3	Program running timing T3	0.0~3600	20.0	○
F9.14	Program running timing T4	Program running timing T4	0.0~3600	20.0	○

Function Code	Function code name	LED display	Setting range	Factory default value	Property
F9.15	Program running timing T5	Program running timing T5	0.0~3600	20.0	○
F9.16	Program running timing T6	Program running timing T6	0.0~3600	20.0	○
F9.17	Program running timing T7	Program running timing T7	0.1~3600	20.0	○
F9.18	Step T1 program running setting	Step T1 program running setting	1 F/r ~ 4 F/r	1F	○
F9.19	Step T2 program running setting	Step T2 program running setting	1 F/r ~ 4 F/r	1F	○
F9.20	Step T3 program running setting	Step T3 program running setting	1 F/r ~ 4 F/r	1F	○
F9.21	Step T4 program running setting	Step T4 program running setting	1 F/r ~ 4 F/r	1F	○
F9.22	Step T5 program running setting	Step T5 program running setting	1 F/r ~ 4 F/r	1F	○
F9.23	Step T6 program running setting	Step T6 program running setting	1 F/r ~ 4 F/r	1F	○
F9.24	Step T7 program running setting	Step T7 program running setting	1 F/r ~ 4 F/r	1F	○
F9.25	Record of PLC steps	Record of PLC steps	1~7	0	*
F9.26	PLC running time	PLC running time	0.0~3600	0	*
F9.27	Multi-step frequency 8	Multi-step frequency 8	0.00~Max frequency	50.00 Hz	○
F9.28	Multi-step frequency 9	Multi-step frequency 9	0.00~Max frequency	50.00 Hz	○
F9.29	Multi-step frequency 10	Multi-step frequency 10	0.00~Max frequency	50.00 Hz	○
F9.30	Multi-step frequency 11	Multi-step frequency 11	0.00~Max frequency	50.00 Hz	○
F9.31	Multi-step frequency 12	Multi-step frequency 12	0.00~Max frequency	50.00 Hz	○
F9.32	Multi-step frequency 13	Multi-step frequency 13	0.00~Max frequency	50.00 Hz	○
F9.33	Multi-step frequency 14	Multi-step frequency 14	0.00~Max frequency	50.00 Hz	○
F9.34	Multi-step frequency 15	Multi-step frequency 15	0.00~Max frequency	50.00 Hz	○
F9.35	Multi-step frequency 1 selection for PLC	Multi-step frequency 1 selection for PLC	0:Multi-step digital setting 1: A11 terminal 2: A12 terminal 3: keyboard potentiometer 4: Pulse input	0	○
F9.36	Multi-step frequency 7 selection for PLC	Multi-step frequency 7 selection for PLC		0	○

Group FA Swing Frequency

Function Code	Function code name	LED display	Setting range	Factory default value	Property
FA.00	Swing frequency amplitude	Swing frequency amplitude	0.0~50.0%	0.0%	○
FA.01	Jitter frequency	Jitter frequency	0.0~50.0% (Relative to FA.00)	0.0%	○
FA.02	Jitter Time	Jitter Time	5~50ms	5ms	○
FA.03	Swing frequency operating cycle	Swing frequency operating cycle	0.1~999.9s	10.0s	○
FA.04	Wobble ratio	Wobble ratio	0.1~10.0	1.0	○
FA.05	Swing setup mode	Swing setup mode	0: Relative to the central frequency 1: Relative to maximum frequency	0	○
FA.06	Reserved	Reserved	Reserved	Reserved	○
FA.07	Reserved	Reserved	Reserved	Reserved	○

Group Fb Fixed Length

Function Code	Function code name	LED display	Setting range	Factory default value	Property
Fb.00	Preset length	Preset length	0~65530	0	○
Fb.01	Actual length	Actual length	0~65530	0	*
Fb.02	Number of pulses each meter	Number of pulses each meter	0.1~6553.0	100.0	○

Group FC Protection and Fault Parameters

Function Code	Function code name	LED display	Setting range	Factory default value	Property
FC.00	Motor overload protection mode selection	Overload protection selection	0: Disabled 1: Common motor (with low speed compensation) 2: Variable frequency motor (without low speed compensation)	1	×
FC.01	Electro thermal protective value	Electro thermal protective value	20~110%	100%	○
FC.02	Pre-overload detection Level	Pre-overload detection Level	30.0~200.0%	160.0%	×
FC.03	Pre-Overload detection time	Pre-Overload detection time	0.0~80.0s	60.0s	×
FC.04	Current amplitude limit	Current amplitude limit	0:Invalid 1: Valid during Acceleration and deceleration, invalid in constant speed Operation 2: Valid	1	○

AD300 Performance Vector Control /Torque Control Inverter User manual

Function Code	Function code name	LED display	Setting range	Factory default value	Property
FC.05	Current amplitude limiting level	Current amplitude limiting level	Type G: 80.0~200.0% Type P: 60.0~150.0%	Type G: 160.0% Type P: 120.0%	○
FC.06	Over-voltage at stall function selection	Over-voltage at stall function selection	0:Disabled (The proposed option, when braking resistor is mounted) 1: Enabled only speed-down 2: Enabled always	1	×
FC.07	Over-voltage point at stall	Over-voltage point at stall	110.0~150.0%(Bus voltage)	380V: 140.0% 220V: 120.0%	×
FC.08	Input phase loss detection level (SPI)	Input phase loss detection level (800V corresponds to 100%)	1~100%	20%	×
FC.09	Input phase loss detection delay time	Input phase loss detection delay time	2~255s	10s	×
FC.10	Output phase loss detection level (SPO)	Output phase loss detection level (Motor rated current corresponds to 100%)	0~100%	0%	×
FC.11	Output phase loss detection delay time	Output phase loss detection delay time	0.0~2.0s	0.2s	×
FC.12	Fault auto reset times	Fault auto reset times	0~10,"0" means "auto reset" is disabled. Only 3 faults have auto reset function	0	×
FC.13	Fault auto reset interval	Fault auto reset interval	2.0~20.0s	5.0s	×

Group Fd Communication Parameters

Function Code	Function code name	LED display	Setting range	Factory default value	Property
Fd.00	communication action	communication action	0: Enabled 1: Disabled	0	○
Fd.01	Local address	Local address	1~247	1	○
Fd.02	Baud rate	Baud rate	0: 1200BPS 1: 2400BPS 2: 4800BPS 3: 9600BPS 4: 19200BPS 5: 38400BPS	3	○
Fd.03	Data format	Data format	0: Even parity check 1: Odd parity check 2: No parity check	0	○

Function Code	Function code name	LED display	Setting range	Factory default value	Property
Fd.04	Communication Timeout time	Communication Timeout time	0.0~100.0s 0: No timeout Setting Others: Detection time	0.0s	○
Fd.05	Response delay	Response delay	0~500ms	5ms	○

Group FE Keyboard and Display

Function Code	Function code name	LED display	Setting range	Factory default value	Property
FE.00	LCD Language selection	LCD Language selection	0: Chinese 1: English	0	○
FE.01	MFK Key function selection	MFK Key function selection	0: MFK inactive 1: JOG running 2: Switching between forward rotation and reverse rotation 3: UP/DOWN clear 4: Switching between operation panel command channel and remote command channel (terminal command channel or serial port communication command channel)	0	○
FE.02	STOP key function	STOP key function	0: Active only in the keyboard control mode 1: STOP function active in the terminal/ communication control mode 2: Fault reset function active in the terminal/ communication control mode 3: Stop and fault reset function active in the terminal/ communication control mode	2	○
FE.03	Output frequency (Hz) (before compensation)	Output frequency (Hz) (before compensation)	0: No display 1: Display only on stop 2: Display only on run 3: Display on stop and run	2	○
FE.04	Output frequency (Hz) (Actual)	Output frequency (Hz) (Actual)	0: No display 1: Display only on stop 2: Display only on run 3: Display on stop and run	0	○
FE.05	Reference frequency (Hz, flashes)	Reference frequency (Hz)	0: No display 1: Display only on stop 2: Display only on run 3: Display on stop and run	1	○
FE.06	Output current(A)	Output current(A)	0: No display 1: Display only on stop 2: Display only on run 3: Display on stop and run	2	○
FE.07	Bus voltage (V)	Bus voltage (V)	0: No display 1: Display only on stop 2: Display only on run 3: Display on stop and run	0	○

AD300 Performance Vector Control /Torque Control Inverter User manual

Function Code	Function code name	LED display	Setting range	Factory default value	Property
FE.08	Output voltage (V)	Output voltage (V)	0: No display 1: Display only on stop 2: Display only on run 3: Display on stop and run	0	○
FE.09	Output torque (%)	Output torque (%)	0: No display 1: Display only on stop 2: Display only on run 3: Display on stop and run	0	○
FE.10	Reference torque (Hz, flashes)	Reference torque (Hz)	0: No display 1: Display only on stop 2: Display only on run 3: Display on stop and run	0	○
FE.11	Rotate speed (r/min)	Rotate speed (r/min)	0: No display 1: Display only on stop 2: Display only on run 3: Display on stop and run	0	○
FE.12	Reference speed (r/min flashes)	Reference speed (r/min)	0: No display 1: Display only on stop 2: Display only on run 3: Display on stop and run	0	○
FE.13	Output power (kW)	Output power (kW)	0: No display 1: Display only on stop 2: Display only on run 3: Display on stop and run	0	○
FE.14	A11 (V)	A11 (V)	0: No display 1: Display only on stop 2: Display only on run 3: Display on stop and run	0	○
FE.15	A12 (V)	A12 (V)	0: No display 1: Display only on stop 2: Display only on run 3: Display on stop and run	0	○
FE.16	Analog PID feedback	Analog PID feedback	0: No display 1: Display only on stop 2: Display only on run 3: Display on stop and run	0	○
FE.17	Analog PID setup	Analog PID setup	0: No display 1: Display only on stop 2: Display only on run 3: Display on stop and run	0	○
FE.18	Terminal status (no unit)	Terminal status (no unit)	0: No display 1: Display only on stop 2: Display only on run 3: Display on stop and run	0	○
FE.19	Actual length	Actual length	0: No display 1: Display only on stop 2: Display only on run 3: Display on stop and run	0	○
FE.20	Reference length	Reference length	0: No display 1: Display only on stop 2: Display only on run 3: Display on stop and run	0	○

Function Code	Function code name	LED display	Setting range	Factory default value	Property
FE.21	Linear speed (m/s)	Linear speed (m/s)	0: No display 1: Display only on stop 2: Display only on run 3: Display on stop and run	0	○
FE.22	External count value (no unit)	External count value (no unit)	0: No display 1: Display only on stop 2: Display only on run 3: Display on stop and run	0	○

Group FF Running History Record

Function Code	Function code name	LED display	Setting range	Factory default value	Property
FF.00	Type of latest fault	Type of latest fault	0: NULL 1: Uu1 bus Under voltage fault 2: OC1 over current in acceleration 3: OC2 over current in deceleration 4: OC3 over current in constant speed 5: Ou1 over voltage in acceleration 6: Ou2 over voltage in deceleration 7: Ou3 over voltage in constant speed 8: GF Ground Fault 9: SC Load Short-Circuit 10: OH1 Radiator over heat 11: OL1 Motor overload 12: OL2 Inverter overload 13: EFO communication fault 14: EF1 external terminal fault 15: SP1 Input phase failure or Unbalance 16: SPO Output phase failure or Unbalance 17: EEP EEPROM Fault 18: CCF Transmission between the inverter and keyboard cannot be established 19: bCE Brake unit fault 20: PCE Parameter copy Error 21: IDE Hall current detection fault 22: ECE PG fault	NULL	*
FF.01	Output frequency at latest fault	Output frequency at latest fault	0~Frequency upper limit	0.00Hz	*
FF.02	Reference frequency at latest fault	Reference frequency at latest fault	0~Frequency upper limit	0.00Hz	*
FF.03	Output current at latest fault	Output current at latest fault	0~2* inverter rated current	0.0A	*

Function Code	Function code name	LED display	Setting range	Factory default value	Property
FF.04	Bus voltage frequency at latest fault	Bus voltage frequency at latest fault	0~1000V	0V	*
FF.05	Running status frequency at latest fault	Running status frequency at latest fault	0: StP Stop 1: Acc acceleration 2: dEc deceleration 3: con constant	0	*
FF.06	Fault history 1 (Last One)	Fault history 1 (Last One)	The same as FF.00	NULL	*
FF.07	Fault history 2	Fault history 2	The same as FF.00	NULL	*
FF.08	Total power on time	Total power on time	0~65530h	0h	*
FF.09	Total running time	Total running time	0~65530h	0h	*
FF.10	Resevred	Resevred	Resevred	Resevred	-
FF.11	Soft Software version number of control board	Soft Software version number of control board	1.00~10.00	1.00	-
FF.12	Non-standard version number of software	Non-standard version number of software	0~255	0	-

Group FP Protection Parameters

Function Code	Function code name	LED display	Setting range	Factory default value	Property
FP.00	User password	User password	0: No password Others: password protection	0	○
FP.01	Parameter write-in protection	Parameter write-in protection	0: All parameters are allowed modifying 1: Only FP.01 and FP.03 can be modified 2: All parameters aren't allowed read	0	○
FP.02	Parameter initialization	Parameter initialization	0: No operation 1: Clear fault history When FP.02 is set to 1, the fault records of FF.00~FF.07 will be cleared. 2: Restore to defaults	0	×
FP.03	Parameter copy	Parameter copy	0: No action 1: Parameters download 2: Parameters upload(except motor's parameters) 3: Parameters upload (all parameters)	0	×
FP.04	Parameter upload protection	Parameter upload protection	0: Protection enabled 1: Protection disabled	0	×
FP.05	G/P model selection	G/P model selection	0: Type G 1: Type P	0	×

Chapter 6 Parameter description

Note:

The value in the “ **I** ” indicates the factory default value of the parameter.

6.1 Group 0 Basic Function

F0.00 Model display	Range: 【Model dependent】
---------------------	---------------------------------

This parameter is provided only for the user to view the factory default model and cannot be modified.

0: G model

1: P model

F0.01 Control operation mode	Range: 0~2 【0】
------------------------------	-----------------------

0: Vector control 1 without encoder speed feedback

Offering excellent vector control performance and insensitive to motor parameters. It is applicable to most applications.

1: Vector control 1 without encoder speed feedback

Precise speed sensorless vector control technology realizes AC motor decoupling, enabling the DC motorization of operation control. It's applicable to high performance applications and features high rotation speed precision, high torque precision and eliminates the need for pulse encoder.

2: Vector control with encoder speed feedback

It is applicable to the applications where high-precision speed control or torque control is required. One inverter can only drive one motor loads, such as paper-making machine, lifting machine and elevator.

3: V/F control

It is applicable to the applications where the load requirements are rather low or one inverter drives multiple motors, such as fan and pump loads. It can be used in the applications where one inverter drives multiple motors.

F0.02 Run command source selection	Range: 0~2 【0】
------------------------------------	-----------------------

0: Operation panel command (“LOCAL/REMOT” LED OFF)

Perform running command control with keys on the operation panel, such as RUN, STOP/RES keys.

1: Terminal command channel (“LOCAL/REMOT” LED ON)

Perform running command control by the multifunctional input terminals such as FWD, REV, JOGF, JOGR, etc.

2: Serial port communication command channel (“LOCAL/REMOT” LED flashes)

The running command is sent by the host computer via the communication mode. When selecting this item, it must be used together Modbus RTU of Shenzhen autitude electrical TechnologyCo., Ltd.

F0.03 Frequency setting 1	Range: 0~8 【0】
F0.04 Frequency setting 2	Range: 1~8 【1】

0: Digital setup

The initial value is the value of F0.06 “Digital Setup Preset Frequency”. It can change the setup frequency value of the inverter through the keys “▲” and “▼” of the keyboard or UP and DOWN of multifunctional input terminals (select through F0.08). The changed value is recorded or not in case of inverter power failure is determined by the parameter F0.09. “Non-recorded” means that the setup frequency value is recovered to the value of F0.06 “Digital Setup Preset Frequency” in case of inverter power failure.

1: Terminal AI1

2: Terminal AI2

It means that the frequency is determined by the analog input terminal. AI1 refer to voltage input of 0 to 10V. AI2 can be used as either voltage input of 0V to 10V or current input of 4mA to 20mA, which can be selected by the SW1 jumper on the control board.

3: PULSE setup

The frequency setup is given by the terminal pulse. Pulse reference signal specification: voltage range of 9V to 30V and frequency range of 0kHz to 50kHz.

4: serial commnication

It means that the main frequency source is given by the host computer via the communication mode.

5: MS (Multi-step) Speed

Select Multi-step speed running mode. It needs to set Group F6 “Input Terminal” and Group F9 “Multi-step speed and PLC” parameters to determine the relative relationship between the reference signal and the reference frequency.

6: Programmable Logic Controller (PLC)

Select simple PLC mode. When the frequency source is simple PLC, it needs to set Group F9 “Multi-step Speed and PLC” parameters to determine the reference frequency.

7: PID

Select process PID control. In this case, it needs to set Group F8 “PID Parameters”. The running frequency of the inverter is that after PID functions

8: keyboard potentiometer

Note:

- ◆ *In frequency setting 1, the Multi-step is prior to others 'frequency soruce.*
- ◆ *In the case of the frequency setting 1+ the frequency setting 1, when the frequency setting 1 source is digital reference, the preset frequency (F0.06) has no action, and the value (adjusted by through the keys “▲” and “▼” of the keyboard or UP and DOWN of multifunctional input terminals) is overlapped at the frequency 2 as the final frequency.*
- ◆ *Pulse given can only be input from the multifunctional input terminal X4 or X5.*

F0.05 Frequency setting selection	Range: 0~6 【0】
-----------------------------------	----------------

This parameter is used to select the frequency reference channel. The frequency reference is realized through combination of frequency setting 1 and frequency setting 2.

0: Frequency setting 1

The frequency reference is determined by the selected channel of the frequency setting 1.

1: Frequency setting 2

The frequency reference is determined by the selected channel of the frequency setting 2.

2: Frequency setting 1 + Frequency setting 2

5: MIN (Frequency setting 1, Frequency setting 2)

6: MAX (Frequency setting 1, Frequency setting 2)

The frequency reference is determined by frequency setting 1 and frequency setting 2 after the corresponding arithmetic.

3: Switching between Frequency setting 1 and Frequency setting 2 via terminal

The frequency reference can switch between the Frequency setting 1 and Frequency setting 2 via the multifunctional input terminal “Frequency Source Switching”.

4: Switching between (Frequency setting 1+ Frequency setting 2) and Frequency setting 2 via terminal

The frequency reference can switch between the Frequency setting 1+ Frequency setting 2 and Frequency setting 2 via the multifunctional input terminal “Frequency Source Switching”.

F0.06 UP/DOWN Preset frequency	Range: 0.00~Max frequency 【0.00Hz】
---------------------------------------	---

When the frequency source is selected as “Digital setup” or “Terminals UP/DN”, this function code is the initial value of frequency digital setup of the inverter.

F0.07 Terminal UP/DOWN rate	Range: 0.001~50.00Hz/s 【1.00Hz/s】
------------------------------------	--

Terminal UP/DOWN rate is used to define the change rate of reference frequency that is changed by terminal or keyboard UP/DOWN.

F0.08 UP/DOWN keyboard and terminal select	Range: 0~2 【1】
---	-----------------------

This parameter is used to select the UP/DOWN channel when the frequency reference is digital setup.

0: Active keyboard and terminal UP/DOWN

1: Active only in keyboard UP/DOWN

2: Active only in terminal UP/DOWN

F0.09 UP/DOWN Power failure record selection	Range: 0~2 【0】
---	-----------------------

0: Power failure record

“Recorded” means that the setup frequency upon restart of inverter due to power failure remains the same.

1: Power failure non-record

“Power failure non-recorded” means that the setup frequency value is recovered to the value of F0.06 “Digital Setup Preset Frequency” in case of inverter power failure.

2: Stop non-record

“Stop non-record” means that the setup frequency value is recovered to the value of F0.06 “Digital Setup Preset Frequency” in case of the inverter stop.

F0.10 Basic frequency	Range: 0.10~600.0Hz 【 50.00Hz】
F0.11 Max frequency	Range: MAX[50.00Hz, Frequency upper limit,frequency reference]~600.0Hz 【 50.00Hz】
F0.12 Frequency upper limit	Range: Frequency lower limit~Max frequency 【 50.00Hz】
F0.13 Frequency lower limit	Range: 0.00~Frequency upper limit 【 0.00Hz】
F0.14 Max output voltage	Range: 110~440V 【Model dependent】

The basic frequency (F_b) is the min output frequency when the output voltage of inverter is equal to rated voltage. Usually, the motor rated frequency can be treated as basic frequency.

The max frequency (F_{max}) is the frequency allowed to be maxi output of this series inverter.

The frequency upper limit (f_H) and frequency lower limit (f_L) are the maximum and minimum operating frequency of the motor set according to the production process requirement by the user during the use.

The maximum output voltage V_{max} is the output voltage when the inverter is in basic operating frequency.

The basic frequency, the max frequency, the frequency upper limit, the maximum output voltage and the basic frequency relationship, as shown in Fig.6-1

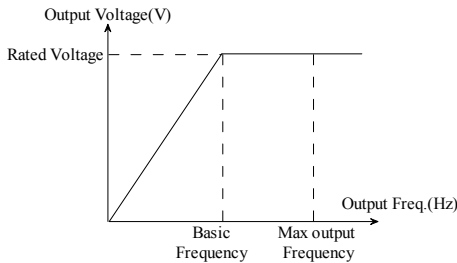

Fig.6-1 V/F characteristic diagram

F0.15 Carrier frequency	Range: 1.0~16.0 【Model dependent】
-------------------------	--

This parameter is used to adjust the carrier frequency of the inverter. The value of this series inverter carrier frequency is show as following Tab.6-1. The adjustment of carrier frequency will have influences on the following performances, as shown Tab.6-2.

Tab.6-1 The value of this series inverter carrier frequency

Model	Range	Factory default value
Type G: 2.2~11kW Type P: 4~15kW	1.0~16.0kHz	8.0kHz
Type G: 15~22kW Type P: 18.5~30kW	1.0~10.0kHz	6.0kHz
Type G: 30~45kW Type P: 37~55kW	1.0~10.0kHz	4.0kHz
Type G: 55~75kW Type P: 75~90kW	1.0~6.0kHz	3.0kHz
Type G: ≥90kW Type P: ≥110kW	1.0~3.0kHz	2.0kHz

Table 6-2 the influences of carrier frequency

Carrier frequency	Low to high
Motor noise	high to low
Motor temperature rise	high to low
Output current waveform	poor to good
inverter temperature rise	Low to high
Leakage current	low to high
External radiation interference	low to high

F0.16 Carrier frequency auto-adjustment selection	Range: 0~1 【0】
---	-----------------------

0: non- adjustment

Carrier frequency will not be adjusted automatically according to the temperature of inverter.

1: Adjustment

Inverter can adjust automatically carrier frequency through temperature check according to the weight of load. Maintain continuously reliable operation by keeping operating with low noise at low loads and controlling the temperature of inverter at heavy load.

F0.17 Keyboard direction setting selection	Range: 0~1 【0】
--	-----------------------

This parameter is used to select the motor rotation direction when the inverter running command channel 1 is keyboard.

0: Forward rotation

1: Reverse rotation

F0.18 Wiring direction of motor	Range: 0~1 【0】
---------------------------------	-----------------------

The direction of the motor may be different from the actual direction of motor. User can change the phase-sequence of motor or change the value of this parameter to make them agree with each other.

0: Positive sequence

1: Antitone sequence

F0.19 Acceleration time1	Range: 0.1~3600s 【6.0/20.0s】
F0.20 Deceleration time1	Range: 0.1~3600s 【6.0/20.0s】

Acceleration time: The time that the inverter accelerates from 0 frequency to maximum frequency.

Deceleration time: The time that the inverter decelerates from maximum frequency to 0 frequency.

This series inverter has defined 4 types of Acc/Dec time. Here, only Acc/Dec time 1 is defined, and Acc/Dec time 2~4 can be defined in F2.03~F2.08. User can select different Acc/Dec time by external multifunction input terminal. In addition, user can select different Acc/Dec time in PLC operation.

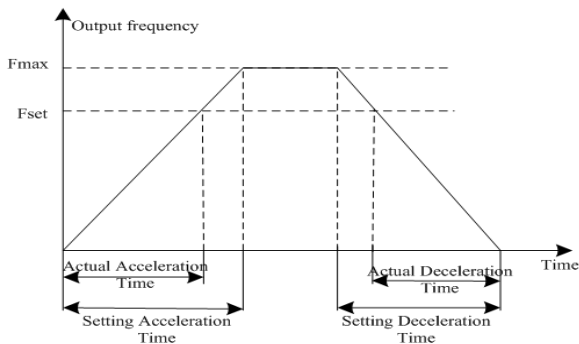

Fig.6-2 Schematic diagram for acceleration/deceleration time

6.2 Group 1 Start and Stop Control

F1.00 Start mode	Range: 0~2 【0】
------------------	-----------------------

0: Start directly

The inverter starts running according to the start frequency (F1.01) and the start frequency holding time (F1.02).

1: DC brake first and then start at start frequency

The inverter starts perform DC braking prior to start. It is applicable to the applications where reverse rotation is likely to occur when small loads are started.

2: Speed tracking and start

The inverter judges the motor rotation speed firstly and then starts at the frequency of the tracked rotation speed of the motor. The rotating motor will be started smoothly without surge.

Note:

The inverters of the power equal to or bigger than 18.5kW have Speed tracking function.

F1.01 Start frequency	Range: 0.10~60.00Hz 【0.50Hz】
F1.02 Start frequency holding time	Range: 0.0~10.0s 【0.0s】

Start frequency is the initial frequency at which the inverter starts, see f_s as shown in Fig.6-3 ; Holding time of starting frequency is the time during which the inverter operates at the starting frequency, see t_1 as shown in Fig.6-3:

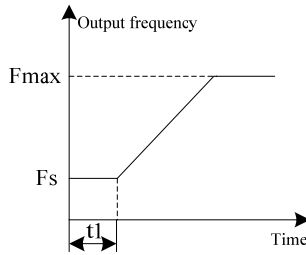

Fig.6-3 Start frequency and Start frequency holding time

Note:

Starting frequency is not restricted by the frequency lower limit.

F1.03 DC injection braking time at start	Range: 0.0~100.0%Inverter rated current 【0.0%】
F1.04 DC injection braking time before start	Range: 0.0~30.0s 【0.0s】

These parameters are only valid when the inverter starts to run according to “DC brake first and then start at start frequency” mode. The higher the DC brake current is, the higher the brake force is.

Note:

If DC injection braking time or brake current is zero, the DC injection braking is invalid.

F1.05 Acceleration /Deceleration mode	Range: 0~1 【0】
---------------------------------------	-----------------------

0: Linear

The output frequency increases or decreases along the straight line. The speed-up/speeddown time varies with the setup acceleration/ deceleration time. This series inverter provides four types of speed-up/speed-down time. It can select speed-up/speed-down time via the multifunctional digital input terminals.

1: S-curve

The output frequency increases or decreases along the S curve. S curve is generally used in the applications where start and stop processes are relatively flat, such as elevator and conveyor belt. Refer to F1.06 and F1.07 for the meanings of the parameters.

F1.06 Time of S-curve initial	Range: 10.0~50.0% 【30.0%】
F1.07 Time of S-curve rising	Range: 10.0~80.0% 【40.0%】

The parameters of F1.06 and F1.07 are valid only when Acceleration /Deceleration mode is S-curve (F1.05=1) and P1.06+P1.07≤90%.

Starting process of S-curve is shown in Fig.6-4 as “①”, where the changing rate of output frequency increases from 0;

Rising process of S-curve is shown in Fig.6-4 as “②”, where the changing rate of output frequency is constant;

Ending process of S-curve is shown in Fig.6-4 as “③”, where the changing rate of output frequency decreases to zero.

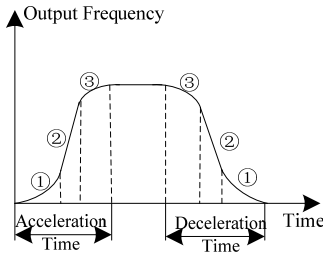

Fig.6-4 S-curve acceleration/deceleration

F1.08 Stop mode	Range: 0~2 【0】
-----------------	-----------------------

0: Deceleration to stop

After receiving the stop command, the inverter reduces its output frequency within the Dec time, and stops when the frequency decreases to zero.

1: Coast to stop

After receiving the stop command, the inverter stops output immediately and the load stops under the effects of mechanical inertia.

2: Deceleration +DC braking

After receiving the stop command, the inverter reduces its output frequency according to the Dec time and starts DC injection braking when its output frequency reaches the preset frequency of braking. The relative parameters is difined in F1.09~F1.12.

F1.09 DC brake beginning frequency at stop	Range: 0.00~max frequency 【0.00Hz】
F1.10 DC brake waiting time at stop	Range: 0.00~10.00s 【0.00s】
F1.11 DC brake current at stop	Range:0.0~100.0%Inverter rated current 【0.0%】
F1.12 DC brake time at stop	Range: 0.0~30.0s 【0.0s】

DC injection braking frequency at stop is the frequency at which DC injection braking action begins when the inverter in Dec-to-stop process. In the process of constant rate deceleration, if the output frequency is at or below the “DC injection braking frequency at stop, the DC injection braking function will startup.

DC brake waiting time at stop: Prior to the beginning of DC brake at stop, the inverter stops output and starts DC brake upon this delay. It is used to prevent the over current fault caused by DC brake beginning when the speed is relatively high.

DC brake current at stop: It refers to the added DC brake quantity. The higher this value is, the better the DC brake effect is.

DC brake time at stop: It refers to the added time of the DC brake quantity.

Note:

When DC brake current or DC brake time at stop is zero, it indicates there is no DC brake process.

F1.13 Energy consumption braking selection	Range: 0~1 【0】
--	-----------------------

0: Disabled

1: Enabled

For large rotating inertia applications and when rapid stop by braking is required, select matched braking unit and braking resistance and set braking parameter for the motor stop rapidly by braking.

Note:

This function is only valid when the inverter power is smaller than 18.5kW.

F1.14 Energy consumption braking unit action voltage	Range: 380V: 650~750V 【700V】 220V: 360~390V 【380V】
--	---

The motor can be stopped rapidly by energy braking with the appropriate action voltage.

F1.15 Restart after power off	Range: 0~1 【0】
-------------------------------	-----------------------

0: Disable

Inverter will not automatically restart when power on again until run command takes effect.

1: Enable

When inverter is running, after power off and power on again, if run command source is keypad control (F0.02=0) or communication control (F0.02=2), inverter will automatically restart after delay time determined by F1.16; if run command source is terminal control (F0.02=1), inverter will automatically restart after delay time determined by F1.16 only if FWD or REV is active.

Note:

The function supports automatic operation of the inverter upon power resume normal after power failure. Be careful in using this function.

F1.16 Waiting time for restart	Range: 0.0~3600s 【0.0s】
--------------------------------	--------------------------------

This parameter defines the value of waiting time for restart.

6.3 Group 2 Auxiliary Function

F2.00 Jog running frequency	Range: 0.00~50.00 【5.00Hz】
F2.01 Jog Acceleration time	Range: 0.0~3600s 【20.0s】
F2.02 Jog Deceleration time	Range: 0.0~3600s 【20.0s】

These parameters define the frequency and acc/dec time of the JOG operation. In JOG operation, the inverter starts according to starting mode 0 (F1.00=0) and stops according to stopping mode 0 (F1.08=0).

F2.03 Acceleration time2	Range: 0.1~3600s 【20.0s】
F2.04 Deceleration time2	Range: 0.1~3600s 【20.0s】
F2.05 Acceleration time3	Range: 0.1~3600s 【20.0s】
F2.06 Deceleration time3	Range: 0.1~3600s 【20.0s】
F2.07 Acceleration time4	Range: 0.1~3600s 【20.0s】

F2.08 Deceleration time4	Range: 0.1~3600s 【20.0s】
--------------------------	---------------------------------

Define Acc/Dec time 2, 3 and 4 respectively (Acc/Dec time 1 is defined in F0.19 and F0.20). Acc/Dec time 1, 2, 3 and 4 can be selected via external multifunction input terminals. If all terminals related with Acc/Dec time are invalid, the inverter will take Acc/Dec time 1 as Acc/Dec time. However, when the inverter chooses PLC or JOG operation, Acc/Dec time will not be controlled by external terminals, but be set by parameter of PLC or JOG.

F2.09 Skip frequency 1	Range: 0.00~600.0Hz 【0.00Hz】
F2.10 Skip frequency 2	Range: 0.00~600.0Hz 【0.00Hz】
F2.11 Skip frequency amplitude	Range: 0.00~15.00Hz 【0.00Hz】

To avoid mechanical resonant, the inverter can skips some running points, which is called Jump frequency. As shown in Fig.6-5.

This series inverters can set two jump frequency points, and the jump frequency amplitude can overlap or nesting. If overlapped, the range broadens. When all two jump frequency set to 0.00 Hz, the jump function will be disabled.

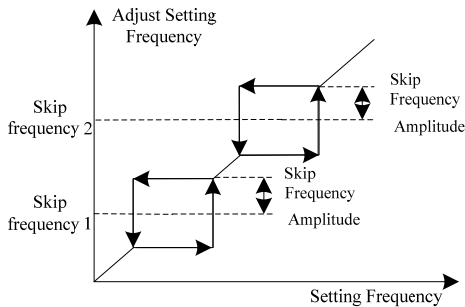

Fig.6-5 Jump Frequency

F2.12 Reverse control	Range: 0~1 【0】
-----------------------	-----------------------

For some production equipment, reverse operation may cause equipment damage. This function can be used to prevent reverse operation.

- 0**: Reverse rotation enabled
- 1**: Reverse rotation disable

F2.13 Forward/ Reverse rotation dead-zone	Range: 0.0~3600s 【0.0s】
---	--------------------------------

Set F2.13 to realize the waiting time for the zero-crossing of rotation speed when the inverter switches from forward rotation to reverse rotation (or from reverse rotation to forward rotation), as shown Fig.6-6.

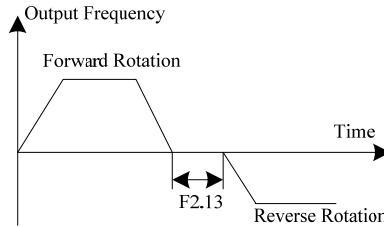

Fig.6-6 FWD/REV switching time diagram

F2.14 Start frequency lower than frequency lower limit action	Range: 0~1 【0】
---	----------------

This parameter is used to select the running status of the inverter when the setup frequency is lower than the frequency lower limit.

- 0: Run with frequency lower limit
- 1: Zero frequency operation

F2.15 Running time to action selection	Range: 0~1 【1】
--	----------------

- 0: Continue running
- 1: Stop

F2.16 Energy saving control selection	Range: 0~1 【1】
---------------------------------------	----------------

- 0: Disabled
- 1: Enabled

Output voltage will decrease automatically as the loads decrease under proper operation. The inverter maximally decreases reactive power to offer further energy savings.

Note:

This function is valid only when the Control Operation Mode is V/F control (F0.02 = 3).

F2.17 AVR function	Range: 0~2 【2】
--------------------	----------------

- 0: Disabled
- 1: Enabled
- 2: Disabled only at speed-down

AVR means automatic output voltage regulation. When AVR function is invalid, the output voltage will fluctuate when the power supply voltage fluctuates. When it is valid, the output voltage would not fluctuate as the input voltage. The output voltage will keep constant within the inverter output capacity.

F2.18 Over modulation enabled	Range: 0~1 【1】
-------------------------------	-----------------------

- 0: Enabled
- 1: Disabled

When the over modulation function is enabled, the inverter voltage output capacity can be improved. However, if the output voltage is too high, the output current harmonics will increase.

F2.19 Droop control	Range: 0.00~10.00Hz 【0.00Hz】
---------------------	-------------------------------------

When multiple inverters drive the same load, the unbalanced load distribution due to difference speed causes the inverter with faster speed to carry heavier load. The droop control characteristics cause the speed droop change along with the addition of load, which can lead to balanced load distribution.

This parameter is used to adjust the frequency change value of the inverter with droop speed.

Note:

Droop control is valid only when the Control Operation Mode is SVC2 control (F0.02 = 1).

F2.20 Fan control mode	Range: 0~1 【0】
------------------------	-----------------------

- 0: Auto mode

The fan always runs when the inverter is running. After the inverter stops three minutes, the internal temperature detection program will be activated to stop the fan or keep the fan running according to the IGBT's temperature.

- 1: Always Running

The fan always runs when the inverter is power on.

F2.21 Instant power off procession	Range: 0~2 【0】
------------------------------------	-----------------------

- 0: Disabled
- 1: down frequency

When the inverter has instant power off or input voltage fall abruptly, the inverter maintains short time running through decreasing the output frequency to get energy.

- 2: Stop directly

When the bus voltage is lower than the Instant power off frequency down point, the inverter stops according to stop mode (F1.08) .

F2.22 Instant power off frequency down point	Range: 380V: 410~600V 【420V】 220V: 210~260V 【230V】
--	---

F2.23 Instant power off frequency down rate	Range: 0.00~max frequency/s 【10.00Hz/s】
---	--

These parameters define the value of the power off frequency down point and power off frequency down rate.

F2.24 Motor speed display ratio	Range: 0.0~500.0% 【100.0%】
---------------------------------	-----------------------------------

The motor speed display of the keypad is the motor speed×F2.24.

F2.24 UP/DOWN descend to negtive	Range: 0~1 【1】
----------------------------------	----------------

0: Enabled

1: Disable

6.4 Group 3 Vector Control Parameters

F3.00 Speed loop proportional gain 1	Range: 0.1~9.9 【1.0】
F3.01 Speed loop integral time 1	Range: 0.01~10.00s 【0.3s】
F3.02 Switching frequency 1	Range: 0.0~50.00Hz 【5.00Hz】
F3.03 Speed loop proportional gain 2	Range: 0.1~9.9 【1.0】
F3.04 Speed loop integral time 2	Range: 0.01~10.00s 【0.3s】
F3.05 Switching frequency 2	Range: 0.0~50.00Hz 【10.00Hz】

F3.00 and F3.01 are PI adjustment parameters when the running frequency is lower than switching frequency 1 (F3.02). F3.03 and F3.04 are PI adjustment parameters when the running frequency is higher than switching frequency 2. PI parameter of frequency channel between the switching frequency 1 and switching frequency 2 is linear switching between two groups of PI parameters, as shown in the fig.6-7:

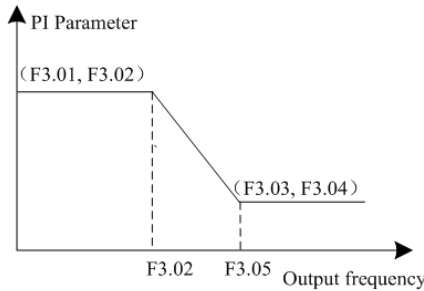

Fig.6-7 Schematic diagram of PI parameter

The speed dynamic response characteristics of the vector control can be adjusted by setting the proportional coefficient and integration time of the speed regulator. Increasing the proportional gain or reducing the integration time can accelerate the dynamic response of the speed loop. However, if the proportional gain is too large or the integration time is too short, it will cause the oscillation of the system.

F3.06 ASR filtering time	Range: 0.0~500.0ms 【0.2ms】
--------------------------	----------------------------

This parameter determines the value of ASR filtering time and needs no adjustment generally.

F3.07 Current loop proportional coefficient	Range: 0~2000 【500】
F3.08 Current loop integral coefficient	Range: 0~6000 【500】

These function codes define the current loop PID parameters, they influence directly the control precision and dynamic response speed and needs no adjustment generally.

F3.09 VC Slip compensation coefficient	Range: 0.0~200.0% 【100.0%】
--	----------------------------

For the speed sensorless vector control, this parameter is used to adjust the speed stabilizing precision of the motor. When the speed is too low due to heavy load of motor, this parameter needs to be enlarged or this parameters needs to be reduced.

For the speed sensor vector control, this parameter can adjust the output current of the inverter carrying the same load.

F3.10 Torque control	Range: 0~5 【0】
----------------------	----------------

0: Torque control is inactive

The inverter performs command speed control. In case of speed control, the inverter outputs frequency in accordance with the setup frequency command, and the output torque automatically matches the load torque.

1~5: Torque control is inactive

The inverter performs torque control. In case of torque control, the inverter outputs torque in accordance with the setup torque command (the parameter determines the torque source), and the output frequency automatically matches the load speed, but the output frequency is limited by the frequency upper limit (refer to F3.12). When the load speed is higher than the setup frequency upper limit, the output frequency of the inverter is limited, and the output torque will be different from the setup torque.

Note:

- ◆ *Analog and pluse Input corresponding setup corresponding to torque setup*
- ◆ *Torque control is valid only when the Control Operation Mode is Vector control 2 without encoder speed feedback or Vector control with encoder speed feedback.*

F3.11 Torque digital setting	Range: 0.0~200.0% 【50.0%】
------------------------------	---------------------------

This parameter is used to define the value of torque digital setting.

F3.12 Torque control upper speed limit	Range: 0~4 【0】
--	----------------

This parameter is used to define the value of speed limit when the inverter is running on torque mode.

0: digital setting (F3.13)

1: AI1

2: AI2

3: PULSE input

4: Serial communication

F3.13 upper speed limit setting	Range: 0.00~300.0Hz 【50.00Hz】
---------------------------------	-------------------------------

Setting the value of the upper speed limit when the parameter F3.12 is equal to zero.

F3.14 Encoder pulse number	Range: 1~9999 【1000】
----------------------------	----------------------

It is used to set the number of pulses of each turn of encoder.

Note:

When the inverter controls the speed sensor vector control, it must set the pulse number of the encoder correctly,

or the motor will run abnormally. If normal operation cannot be realized after correct pulse number of the encoder is set, exchange the connecting positions of Phase A and Phase B of the encoder.

F3.15 Deceleration ratio between motor and encoder	Range: 0.010~50.00 【1.000】
--	----------------------------

If the encoder is directly mounted on the motor shaft, set this parameter to 1. If the encoder is not directly mounted on the motor shaft, there exists deceleration ratio between motor shaft and encoder.

F3.16 PG direction selection	Range: 0~1 【0】
------------------------------	----------------

0: Forward

1: Reverse

The leave-factory value is 0. If the wiring sequence for connecting the encoder to inverter connection board does not match the wiring sequence for connecting inverter to motor, this parameter may be set to “1” to adjust the wiring sequence to avoid re-wiring.

F3.17 Reserved	Range: 0.01~600.0s 【0.10s】
F3.18 Reserved	Range: 0.00~3.00s 【0.10s】
F3.19 Reserved	Range: 0.0~10.0% 【0.1%】
F3.20 Reserved	Range: 0.0~100.0s 【1.0s】

6.5 Group 4 V/F Control Parameters

F4.00 V/F curve setting	Range: 0~4 【0】
-------------------------	----------------

0: Straight V/F. It is suitable for common constant torque load.

1~3: Multi-order decreasing torque. It is suitable for the centrifugal loads such as fan and pump, as shown Fig.6-8.

4: Multiple-point V/F. It is suitable for the special loads such as dehydrator and centrifugal machine.

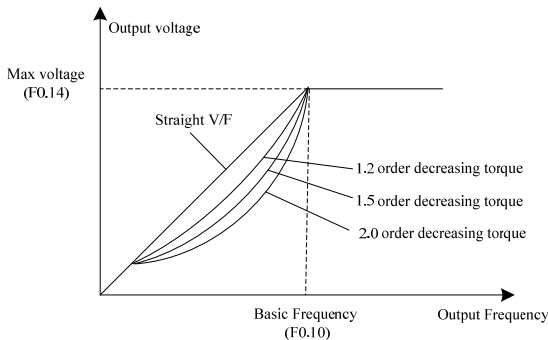

Fig.6-8 Torque-reducing curve

F4.01 V/F frequency point 1	Range: 0.0~F4.03 【10.00Hz】
F4.02 V/F voltage point 1	Range: 0~100.0% 【20.0%】
F4.03 V/F frequency point 2	Range: F4.01~F4.05 【25.00Hz】
F4.04 V/F voltage point 2	Range: 0~100.0% 【50.0%】
F4.05 V/F frequency point 3	Range: F4.03~F0.10 【40.00Hz】
F4.06 V/F voltage point 3	Range: 0~100.0% 【80.0%】

Six parameters of F3-03 to F3-08 define MS V/F curve, shown as Fig.6-9. The setup value of V/F curve is generally set in accordance with the load characteristics of the motor.

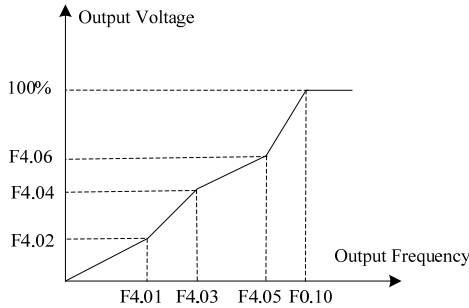

Fig.6-9 V/F-curve defined by user

F4.07 Torque boost	Range: 0.0~30.0% 【0.0%】
F4.08 Cutoff frequency of torque boost	Range: 0.00~60.00Hz 【50.00Hz】

To compensate the low frequency torque characteristics of V/F control, it can boost the output voltage of the inverter at the time of low frequency.

When the torque boost is set to 0.0, the inverter will adopt auto torque boost.

Cutoff frequency of torque boost: Under this frequency, the torque boost is enabled. If it exceeds this setup frequency, the torque boost is inactive. Refer to Fig.6-10 for details.

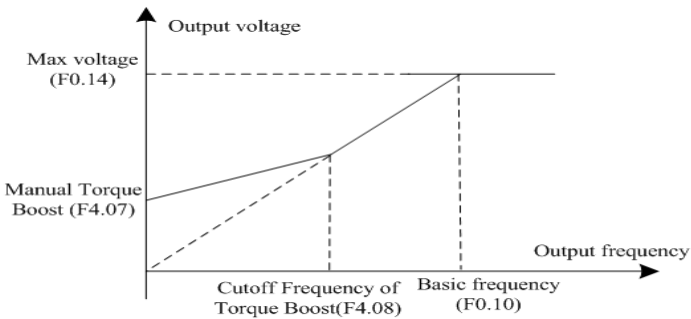

Fig.6-10 Schematic Diagram for Manual Torque Boost

Note:

- ◆ If the torque boost is set to be too large, the motor may be over heat, and the inverter may be over current. In
- ◆ When the inverter drives synchronous motor, torque boost function is recommended to be used and V/F curve should be adjusted according to the motor parameters

F4.09 Slip compensation coefficient	Range: 0.0~200.0% 【0.0%】
F4.10 Slip compensation filtering time	Range: 0.01~2.55s 【0.20s】

Setting the parameters can compensate the slip in the V/F control mode due to load and reduce the change of rotation speed of the motor following the load change. In general, 100% corresponds to the rated slip of the motor with rated load, shown as Fig.6-11.

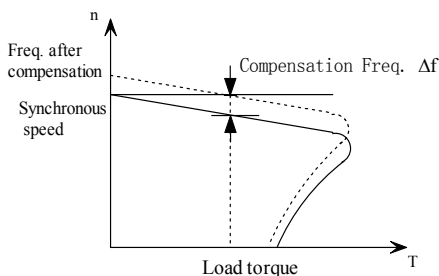

Fig.6-11 Auto slip compensation diagram

In rated torque state, the value of slip compensation is: Gain of Slip Frequency compensation (F4.09) × Rated slip (Synchronous speed- Rated speed)

Electro motion state: Increase the gain of slip compensation (F4.09) gradually when the actual speed is lower than the reference speed.

Generating state: Increase the gain of slip compensation (F4.09) gradually when the actual speed is higher than the reference speed.

Note:

- ◆ The value of automatically slip compensation is dependent on the motor's rated slip; therefore, the motor rated speed (F5.04) must be set correctly.
- ◆ Slip compensation is disabled when Gain of Slip Frequency compensation is set to "0".

F4.11 Voltage source control separately when V/F	Range: 0~4 【0】
--	----------------

0: Disabled

The output voltage and frequency are not controlled separately, the inverter is running according V/F.

1~4: The output voltage and frequency are controlled separately.

The output voltage and frequency are controlled independently.

Note:

- ◆ Analog and pluse Input corresponding setup 100% corresponding to maximum output voltage (F0.14).

F4.12 Voltage digital setting	Range: 0~maximum output voltage 【380V】
-------------------------------	--

This parameter is used to set the value of the output voltage when the voltage is controlled independently.

F4.13 Voltage Acceleration/ Deceleration time	Range: 0.0s~1000.0s 【0.0s】
---	----------------------------

This parameter is used to set the value of the output Voltage Acceleration/ Deceleration time when the voltage is controlled independently. Acceleration/ Deceleration time is the time that the voltage accelerates from 0 to maximum voltage.

6.6 Group 5 Motor Parameters

F5.00 motor type selection	Range: 0~2 【0】
F5.01 Motor polarity number	Range: 2~56 【4】
F5.02 rated power	Range: 0.4~999.9kW 【Model dependent】
F5.03 rated current	Range: 0.1~999.9A 【Model dependent】
F5.04 rated rotation speed	Range: 0~24000rpm 【Model dependent】

F5.00~F5.05 are used to set the motor parameters. In order to ensure the control performance, please set F5.00~F5.05 with reference to the values on the motor nameplate.

Note :

On V/F control, the motor power is allowed to be 20% lower than that of the inverter or 10% higher. On SVC or VC control, the motor power must match that of the inverter; otherwise, the control performance would not be ensured.

F5.05 no-load current I0	Range: 0.1~999.9A 【Model dependent】
F5.06 Stator resistance R1	Range: 0.00%~50.00% 【Model dependent】
F5.07 Leakage Inductive reactance X	Range: 0.00%~50.00% 【Model dependent】
F5.08 Rotor resistance R2	Range: 0.00%~50.00% 【Model dependent】
F5.09 Mutual Inductive reactance Xm	Range: 0.0%~200.0% 【Model dependent】

The above parameters are referred in the fig.6-12:

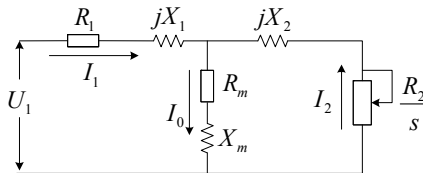

Fig. 6-12 Motor equivalent circuit

In the Fig.6-12, R1, X1, R2, X2, Xm, and I0 represent resistance of stator, leakage inductance of stator, resistance of rotor, leakage inductance of rotor, mutual inductance and current without load respectively. The setting of F5.07 is

the sum of leakage inductance of stator and leakage inductance of rotor.

The above parameters F5.06~F5.09 settings are all percentage values calculated by the following formulas:

V: Rated voltage

I: Motor rated current

Formula used for calculating resistance (resistance of stator or rotor):

$$\%R = \frac{R}{V / (\sqrt{3} \cdot I)} \times 100\%$$

Formula used for calculating inductance (leakage inductance or mutual inductance):

$$\%X = \frac{X}{V / (\sqrt{3} \cdot I)} \times 100\%$$

If motor parameters are known, please set F5.06~F5.09 to the values calculated according to the above formulas.

After motor power F5.02) change, the inverter will change F5.03~F5.09 according to the motor power.

F5.10 Tuning selection	Range: 0~2 【0】
------------------------	----------------

0: No operation

1: Static tuning, it is suitable to the situation as the motor is not easy to disconnected from the load.

Action description: Set the function code to 1 and press RUN key for confirmation, and then the inverter will conduct static tuning.

2: Complete tuning

To ensure the dynamic control performance of the inverter, please select rotary tuning. During the rotary tuning, the motor must be disconnected with the loads (i.e. no-load).

Action description: Set the function code to 2 and press RUN key for confirmation, and then the inverter will conduct rotary tuning.

6.7 Group 6 Input Terminal

F6.00 Terminal Command mode	Range: 0~3 【0】
-----------------------------	----------------

This parameter defines four different control modes that control the inverter operation through external terminals.

0: Two-wire mode 1

This mode is the most commonly used two-line mode. The forward/reverse rotation of the motor is decided by the commands of FWD and REV terminals, As shown in Fig.6-13.

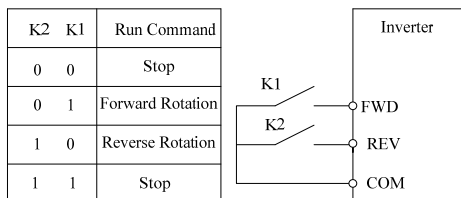

Fig.6-13 Two-wire mode 1

1: Two-wire mode 2

In this mode, both function RUN (Run command) and F/R (Running direction) are used: If RUN is enabled, the inverter will startup. If F/R is selected but disabled, the inverter will run forward. If F/R is selected and enable, the inverter will run reverse. When F/R is not selected, the running direction is defined by function code (F0.17). If RUN is disabled, the inverter will stop. Terminals wiring is show in Fig.6-14

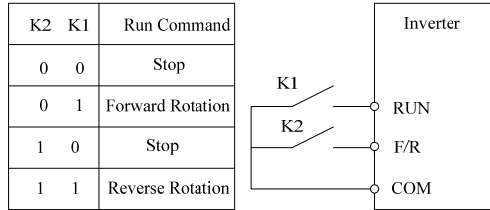

Fig.6-14 Two-wire mode 2

2: Three-wire mode 1

In this mode, HLD is enabled terminal, and the direction is controlled by FWD and REV respectively. However, the pulse is enabled through disconnecting the signal of HLD terminal when the inverter stops. As shown in Fig.6-15

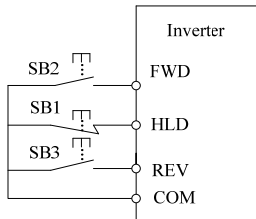

Fig.6-15 Three-wire mode 1

3: Three-wire mode 2

In this mode, HLD is enabled terminal, and the running command is given by FWD, while the direction is determined by the status of REV. Stop command is performed through disconnecting the HLD signal As shown in Fig.6-16. When F/R is not selected, the running direction is defined by function code (F0.17).

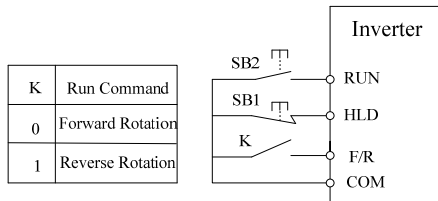

Fig.6-16 Three-wire mode 2

F6.01 X1 terminal input function selection	Range: 0~56 【1】
F6.02 X2 terminal input function selection	Range: 0~56 【2】
F6.03 X3 terminal input function selection	Range: 0~56 【6】
F6.04 X4 terminal input function selection	Range: 0~60 【8】
F6.05 X5 terminal input function selection	Range: 0~60 【19】
F6.06 X6 terminal input function selection	Range: 0~56 【0】
F6.07 X7 terminal input function selection	Range: 0~56 【0】
F6.08 X8 terminal input function selection	Range: 0~56 【0】
F6.08 X9 terminal input function selection	Range: 0~56 【0】

This parameter is used to set the functions of the multifunctional digital input terminals, refer to table 6-3.

Note :

X6~X9 in the IO expansion card.

Table 6-3 Multi-functional input terminal

Setting value	Function	Description
0	NULL	Even when there is signal input, the inverter still has no action. The no operation function can be set on the unused terminals so as to prevent error action.
1	Forward rotation (FWD)	Control the forward rotation and reverse rotation of the inverter via the external terminals
2	Reverse rotation(REV)	
3	RUN	Control the inverter running via the external terminal.
4	FWD/REV running direction	Control the direction of the inverter.
5	HLD self-hold selection	Running signal self-hold terminal, refer to F6.00 operating modes setup.
6	Forward rotation Jog (FJOG)	FJOG refers to Jog forward rotation, while RJOG refers to Jog reverse rotation. For details regarding frequency and Jog acceleration/deceleration time during the Jog running, refer to F2.00, F2.01 and F2.02 function codes.
7	Reverse rotation Jog (RJOG)	
8	RST	It is used as fault reset function on the fault status.
9	Frequency source switching	When the frequency source selection (F0.05) is set to 3, it performs switching between main frequency source1 and auxiliary frequency source 2 via this terminal. When the frequency source selection (F0.05) is set to 4, it performs switching between main frequency source 1 and (main frequency 1 plus auxiliary frequency source 2) via this terminal.
10	Terminal UP	When the frequency is given by the external terminals, it is used as increment and decrement commands of frequency modification When the frequency source is set to digital setup, it can be used to adjust the setup frequency.
11	Terminal DOWN	

Setting value	Function	Description
12	UP/DOWN setup clear	When the frequency reference is digital frequency reference, this terminal can be used to clear the frequency value modified by UP/DOWN and thus restore the reference frequency to the setup value of F0.06 .
13	Coast to stop	The inverter locks the output, and the motor stop process is beyond the inverter control. It is the general method adopted when there is huge load and no requirement for the stop time.
14	DC injection braking	This terminal is enabled, and the inverter directly switches to the DC brake status. Intensity of DC brake refer to DC braking current (F1.11) .
15	Acceleration/deceleration inactive	Protect the inverter from affecting by the external signals (except stop command), and maintain the current frequency.
16	Inverter running prohibit	Once this terminal is enabled, if the inverter is on running status, the inverter will coast to stop immediately, if the inverter is on stop status, the inverter can not run.
17	Multi-step speed terminal 1	It can realize 16S speed through the combination of digital status of these four terminals. Referat tached table 6-4 for the MS speed function description. And K1~K4 corresponds 17~20 function terminal.
18	Multi-step speed terminal 2	
19	Multi-step speed terminal 3	
20	Multi-step speed terminal 4	
21	torque control inactive	The torque control of inverter is inactive.
22	Acceleration/deceleration time selection terminal 1	It can select four types of speed-up/speed-down time through the combination of digital status of these two terminals. Refer to table 6-5 for detail.
23	Acceleration/deceleration time selection terminal 2	
24	External pause normally open input	The inverter decelerates to stop, but al l the running parameters are al l in the memory status, such as PLC parameter, swing frequency parameter and PID parameter. After this signal disappears, the inverter restores to the status before stopping.
25	External pause normally closed input	
26	External fault normally open input	After the external fault signal is sent to the inverter, the inverter reports fault and stops.
27	External fault normally closed input	
28	Running command switching to terminal	When Run command source (F0.02) is 0 or 2, the run command is switching to terminal via this terminal.
29	Running command switching to Keyboard	When Run command source (F0.02) is 1 or 2, the run command is switching to keyboard via this terminal.

Setting value	Function	Description
30	External stop terminal When it is in the keyboard control mode, this terminal can be used to stop, which is similar to STOP key on the keyboard.	External stop terminal When it is in the keyboard control mode, this terminal can be used to stop, which is similar to STOP key on the keyboard.
31	Reserved	Reserved
32	PLC status reset	PLC pauses during the execution process. When it resumes running, it can effectively restore to the initial status of simple PLC via this terminal.
33	Swing frequency pause	The inverter maintains the current frequency. When the terminal is invalidated, the inverter continues the swing frequency status.
34	Swing frequency status reset	The inverter runs on the center frequency.
35	PID pause	PID is inactive temporarily, and the inverter maintains the current frequency output.
36	PID parameters switching	If the terminal is valid, PID parameters are switched to second group.
37	PID action direction reverse terminal	If this terminal is enabled, PID action direction is opposite to the direction set in F8.04.
38	Timing drive input	If the terminal is valid, start the timing, otherwise zero-clear.
39	Counter trig signal input	The input terminal of counting pulse.
40	Counter clear	Clear the counter status.
41	Actual length clear	When the function terminal is enabled, actual length of fixed length will be cleared to zero.
42~56	Reserved	Reserved
57	Pulse input	Only multi-function input terminals X4 and X5 can be defined as this function and if the terminal X4 and X5 are defined simultaneously, only the terminal X4 is valid. The input pulse frequency can be used for frequency reference.
58	Single-phase speed measuring input	Only multi-function input terminals X4 and X5 can be defined as this function and if the terminal X4 and X5 are defined simultaneously, only the terminal X4 is valid.
59	Speed measuring input A	Only multi-function input terminals X4 can be defined as this function
60	Speed measuring input B	Only multi-function input terminals X5 can be defined as this function

Table 6-4 Multi-step frequency Function Description

K4	K3	K2	K1	Frequency Setup	Corresponding Parameter
OFF	OFF	OFF	OFF	F0.06	F0.06
OFF	OFF	OFF	ON	Multi-step frequency 1	F9.00
OFF	OFF	ON	OFF	Multi-step frequency 2	F9.01
OFF	OFF	ON	ON	Multi-step frequency 3	F9.02
OFF	ON	OFF	OFF	Multi-step frequency 4	F9.03
OFF	ON	OFF	ON	Multi-step frequency 5	F9.04
OFF	ON	ON	OFF	Multi-step frequency 6	F9.05
OFF	ON	ON	ON	Multi-step frequency 7	F9.06
ON	OFF	OFF	OFF	Multi-step frequency 8	F9.27
ON	OFF	OFF	ON	Multi-step frequency 9	F9.28
ON	OFF	ON	OFF	Multi-step frequency 10	F9.29
ON	OFF	ON	ON	Multi-step frequency 11	F9.30
ON	ON	OFF	OFF	Multi-step frequency 12	F9.31
ON	ON	OFF	ON	Multi-step frequency 13	F9.32
ON	ON	ON	OFF	Multi-step frequency 14	F9.33
ON	ON	ON	ON	Multi-step frequency 15	F9.34

Table 6-5 Acc/Dec time selection table

Terminal 2	Terminal 1	Acc/Dec time selection
OFF	OFF	Acc tim 1/ Dec time 1
OFF	ON	Acc tim 2/ Dec time 2
ON	OFF	Acc tim 3/ Dec time3
ON	ON	Acc tim 4/ Dec time4

F6.10 Analog Nonlinear Selection

Range: 0~3 **[0]**

0: None

F6.11~F6.15 are used to define AI1 inputs, F6.16~F6.20 are used to define AI2 inputs, and F6.21~F6.25 are used to defined pulse inputs. They are independent and has no effect to each other.

1: AI1

All the parameters from F6.11 to F6.25 are setting points for the AI1 channel, as shown in Fig.6-17. The filter time the parameter F6.15.

2: AI2

All the parameters from F6.11 to F6.25 are setting points for the AI2 channel, as shown in Fig.6-17. The filter time the parameter F6.15.

3: Pulse input

All the parameters from F6.11 to F6.25 are setting points for the Pulse channel, as shown in Fig.6-17. The filter time the parameter F6.15.

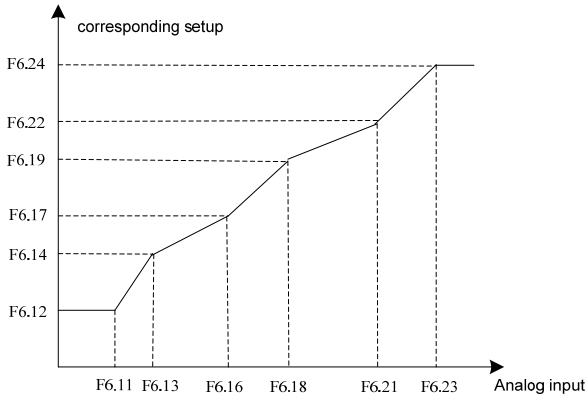

Fig.6-17 Analog input non-linear curve

F6.11 AI1 minimum input (AI1 Terminal)	Setting range: 0.0~F6.13 【0.00V】
F6.12 AI1 minimum Input corresponding setup	Setting range: 0.0~200.0% 【0.0%】
F6.13 AI1 maximum input (AI1 Terminal)	Setting range: F6.11~10.00V 【10.00V】
F6.14 AI1 maximum Input corresponding setup	Setting range: 0.0~200.0% 【100.0%】
F6.15 AI1 input filter time 1 (AI1 Terminal)	Setting range: 0.01~50.00s 【0.05s】
F6.16 AI2 minimum input (AI2 Terminal)	Setting range: 0.00~F6.18 【0.00V】
F6.17 AI2 minimum Input corresponding setup	Setting range: 0.0~200.0% 【0.0%】
F6.18 AI2 maximum input (AI2)	Setting range: F6.16~10.00V 【10.00V】
F6.19 AI2 maximum Input corresponding setup	Setting range: 0.0~200.0% 【100.0%】
F6.20 AI2 input filter time 2 (AI2 Terminal)	Setting range: 0.01~50.00s 【0.05s】
F6.21 PULSE input minimum frequency	Setting range: 0.00~F6.23 【0.00kHz】
F6.22 PULSE input Minimum Frequency Corresponding setup	Setting range: 0.0~200.0% 【0.0%】
F6.23 PULSE input maximum frequency	Setting range: F6.21~50.00kHz 【50.00kHz】
F6.24 PULSE input Maximum Frequency Corresponding setup	Setting range: 0.0~200.0% 【100.0%】
F6.25 Pulse filter time 3 (pulse Input Terminal)	Setting range: 0.01~50.00s 【0.05s】

The above function codes define the relationship between the analog input voltage and analog input setup value. When the analog input voltage exceeds the setup maximum input or minimum input range, the excess part will be calculated as maximum input or minimum input, as shown in Fig.6-18.

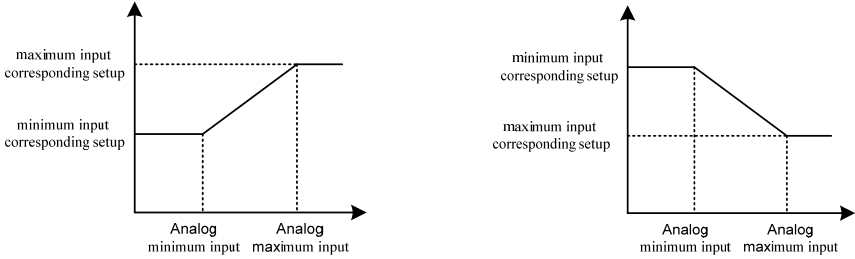

Fig.6-18 Analog input linear curve

F6.26 Polarity of Corresponding setup	Range: 0~63 【0】
---------------------------------------	------------------------

This parameter is used to define the corresponding setup polarity of the AI1, AI2 and Pulse input, refer to below for details:

- | | | | |
|----------------|---|-------------|-------------|
| bit0---- | Polarity of AI1 minimum input Corresponding setup | 0: positive | 1: negative |
| bit1---- | Polarity of AI1 maximum input Corresponding setup | 0: positive | 1: negative |
| bit2---- | Polarity of AI2 minimum input Corresponding setup | 0: positive | 1: negative |
| bit3---- | Polarity of AI2 maximum input Corresponding setup | 0: positive | 1: negative |
| bit4---- | Polarity of Pulse minimum input Corresponding setup | 0: positive | 1: negative |
| bit5---- | Polarity of Pulse maximum input Corresponding setup | 0: positive | 1: negative |
| bit6~bit15---- | Reserved | | |

6.8 Group 7 Output Terminal

F7.00 DO terminal output selection	Range: 0~25 【0】
F7.01 Y1 terminal output selection	Range: 0~25 【1】
F7.02 Y1 terminal output selection	Range: 0~25 【0】
F7.03 Relay 1 (TA/TB/TC) output selection	Range: 0~25 【16】
F7.04 Relay 2 (BRA/BRB/BRC) output selection	Range: 0~25 【0】

Multifunctional output terminal function selection is as follows:

Note:

DO terminal can be used as multifunction output terminal only when F7.21 is equal to 0.

Table6-6 Multifunction output terminal

Setup value	Function	Discription
0	NULL	The output terminal does not have any function.
1	Inverter is running	It indicates the inverter is running, and there is output frequency (can be zero), and ON signal will output at this time.
2	Frequency arrival(FAR)	Please refer to F7.05 for details.
3	Frequency level detection 1 (FDT1)	Please refer to F7.06、 F7.07 for details.
4	Frequency level detection 2 (FDT2)	Please refer to F7.08、 F7.09 for details.
5	Frequency detection when speed-up	When the output frequency is higer than the Up detection frequency (F7.10), it outputs ON signal.
6	Frequency detection when speed-down	When the output frequency is lower than t Down detection frequency (F7.11) on the speed-down status, it outputs ON signal.
7	Zero-speed running	When the inverter output frequency is less than the start frequency, it outputs ON signal.
8	Zero-speed	When output frequency is zero, it outputs ON signal.
9	PLC circulation completion	When the simple PLC has been running for one cycle, it outputs outputs ON signal.
10	Programming Running steps	It indicates the Programming Running steps, Please refer to table 5-7 for details.
11	Ready for running	When the main circuit and control circuit power supply are connected, the inverter protection function is inactive, and the inverter is in running status, it output ON signal.
12	Timing arrival	When the running time exceeds the preset time (F7.14), it output ON signal.
13	counting value arrival	The count value is bigger than the value defined in F7.13, it output ON signal.
14	Preset operating time arrival	When the accumulated running time of the inverter exceeds the setup time F7.15, it outputs ON signal.
15	Torque arriving detection threshold	When motor's torque i exceeds reference value (set by P7.12), it outputs ON signal.
16	Inverter fault output	When the inverter is faulty, it outputs ON signal.
17	Under voltage status output	When the inverter is in under voltage status, it outputs ON signal.
18	Inverter overload prewarning	If the output current is higher than the value defined by FC.02 (Overload detection), it outputs ON signal..
19	Fixed-length arrived, output a high level signals	If the actual length exceeds the preset lengt, t it outputs ON signal.
20	PID Standby	When PID is standby, it outputs ON signal.

Setup value	Function	Discription
21	AI1>AI2	When the analog input AI1 value is higher than AI2 value, it outputs ON signal.
22	AI1<F7.16	When the analog input AI1 value is lower than F7.16, it outputs ON signal.
23	AI1>F7.16	When the analog input AI1 value is higher than F7.16, it outputs ON signal.
24	F7.16<AI1<F7.17	When the analog input AI1 value is higher than F7.16 and is lower than F7.17, it outputs ON signal.
25	Frequency lower limit arrival	When the running frequency reaches frequency lower limit, it outputs ON signal.
26	Auxiliary pump control signal	Auxiliary pump control signal for constant pressure water supply, refer to the parameter F7.28&F7.29 instruction for detail.

Table 6-7 PLC Running Steps

Y2	Y1	D0	Running Steps
OFF	OFF	ON	T1
OFF	ON	OFF	T2
OFF	ON	ON	T3
ON	OFF	OFF	T4
ON	OFF	ON	T5
ON	ON	OFF	T6
ON	ON	ON	T7

F7.05 Frequency arrival detection width	Range: 0.00~10.00Hz 【2.50Hz】
---	------------------------------

If the inverter's output frequency is within the detection width of reference frequency, a pulse signal will be output, as shown in Fig.6-19.

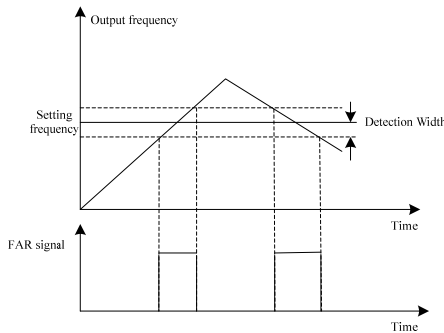

Fig.6-19 FAR detection diagram

F7.06 Frequency detection value 1 (FDT1 level)	Range: 0.00~300.0Hz 【5.00Hz】
F7.07 Frequency detection hysteresis1(FDT1-hysteresis)	Range: 0.00~10.0Hz 【1.00Hz】
F7.08 Frequency detection value 2 (FDT2 level)	Range: 0.00~300.0Hz 【25.00Hz】
F7.09 Frequency detection hysteresis1(FDT2-hysteresis)	Range: 0.00~10.0Hz 【1.00Hz】

Please refer to Fig.6-20 for details.

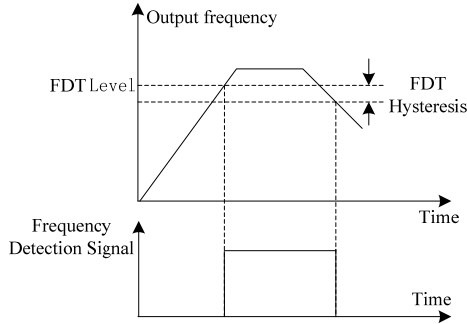

Fig.6-20 FDT level and lag diagram

F7.10 Up detection frequency	Range: 0.00~300.0Hz 【50.00Hz】
F7.11 Down detection frequency	Range: 0.00~300.0Hz 【0.00Hz】

These two parameters define the value of Up detection frequency and Down detection frequency respectively.

F7.12 Torque detection reference	Range: 0.0~200.0% 【100.0%】
F7.13 Preset Count value	Range: 0~9999 【0】
F7.14 Preset Timing value	Range: 0.0~6553.0s 【0.0s】
F7.15 Preset operating time	Range: 0~65530h 【0h】

The above parameters define the value of torque detection reference, preset count, preset timing and Preset operating time respectively.

F7.16 A11 compare threshold 1	Range: 0.00~10.00 【0.00V】
F7.17 A11 compare threshold 2	Range: 0.00~10.00 【0.00V】
F7.18 Analog compare hysteresis	Range: 0.00~30.00 【0.20V】

These parameters define the value of the analog comparison, please refer to table 6-6 for details.

F7.19 AO1 output selection	Range: 0~13 【1】
F7.20 AO2 output selection	Range: 0~13 【0】

F7.21 DO output selection	Range: 0~13 【0】
---------------------------	------------------------

AO1 can be used as either voltage output of 0V to10V or current input of 0mA to 20mA, which can be selected by the jumper on the control board. AO2 refer to voltage output of 0 to 10V. DO output range is defined by the parameters F7.26 and F7.27. These output selection details shown as table 6-8:

Table 6-8 analog output terminal

Setup value	Function	Discription
0	NULL	NULL
1	Running frequency	0~maximun frequency
2	setting frequency	0~maximun frequency
3	output current	0~2* inverter rated current
4	Output voltage	0~Maximum Voltage
5	PID setup	0~10V
6	PID feedback	0~10V
7	Adjust signals	5V
8	Output torque	0~2*motor rated torque
9	Output power	0~2*Inverter rated power
10	Bus voltage	0~1000V
11	AI1	0~10V
12	AI2	0~10V
13	Pulse input	0.1~50.0KHz

F7.22 AO1 output range selection	Range: 0~1 【0】
F7.23 AO2 output range selection	Range: 0~1 【0】

0: 0~10V / 0~20mA

1: 2~10V / 4~20mA

Note:

AO2 output is only voltage.

F7.24 Gain of AO1	Range: 1~200% 【100%】
F7.25 Gain of AO2	Range: 1~200% 【100%】

The inverter output and instrument systems are likely to produce bias, you can adjust the output gain (AO1or AO2) for the meter calibration and the change of measuring range.

F7.26 Max output frequency of DO	Range: Min Pulse value output of DO~ 50.00kHz 【10.00kHz】
F7.27 Min output frequency of DO	Range: 0.00~ Max Pulse value Output of DO

	【0.00kHz】
--	------------------

The above parameters define output pulse frequency range.

F7.28 Delay time for Auxiliary pump run	Range: 0~9999 【0s】
F7.29 Delay time for Auxiliary pump stop	Range: 0~9999 【0s】

The above parameters define the delay time for auxiliary pump, refed Fig.6-21 for details.

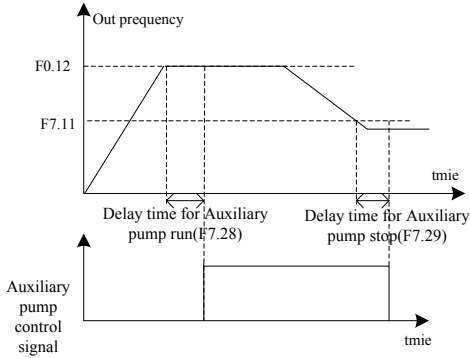

Fig.6-21 auxiliary pump control for constant water supply diagram

6.9 Group F8 PID Parameters

F8.00 PID setup selection	Range: 0~4 【0】
---------------------------	-----------------------

This parameter defined the given channel of PID target quantity.

0: PID setup, Determined by F8.02.

1: AI1 terminal

As 0~10V analog voltage input.

2: AI2 terminal

Through the swith SW1, As 0 ~ 10V analog voltage or 0 ~ 20mA current input.

3: Pulse input

4: serial communication

The input value should in 0~100.00% (0~10000) , 100.00% correspond the full scale of PID.

Note:

The relationship of AI1, AI2 & pulse frequency between the actual physical quantities can be seen in F6.10 ~ F6.26 , its full range (100.0%) of actual physical quantities correspond to the PID full range

F8.01 PID feedback selection	Range: 0~7 【1】
------------------------------	-----------------------

This parameter defined the PID feedback channel.

0: AI1 terminal

As 0~10V analog voltage input.

1: AI2 terminal

Through the swith SW1, As 0 ~ 10V analog voltage or 0 ~ 20mA current input.

2: Pulse input

3: serial communication

The input value should in 0~100.00% (0~10000) , 100.00% correspond the full scale of PID.

4: AI1-AI2

AI1-AI2 as PID feedback, if the result is negative the feedback value is negative

5: AI1+AI2

AI1+ AI2 as PID feedback , if the result is bigger than the actual physical quantities(100%) the PID feedback quantity is the 100% full range.

6: MAX(AI1, AI2)

Take the larger between AI1 and AI2 as the PID feedback.

7: MIN(AI1, AI2)

Take the smaller between AI1 and AI2 as the PID feedback.

F8.02 Analog PID digital setup	Range: 0.0~999.9 【50.0】
---------------------------------------	--------------------------------

When analog PID setting channel select the digital setting (F8.00 = 0), this parameter decide the setting value of the PID.

F8.03 Analog closed loop measuring range	Range: 1.0~999.9 【100.0】
---	---------------------------------

It's the reference of analog PID setting and PID feedback value, it must equal to the actual measuring range . The AI1, AI2 and 100%pulse input correspond with analog PID range.

F8.04 PID action direction	Range: 0~1 【0】
-----------------------------------	-----------------------

0: Positive

When the PID output increases, the output frequency will increase and the controlled physical value will increase, such as water supply system.

1: Negative

When the PID output decrease,The motor speed decrease with setting value, such as refrigeration system.

F8.05 PID proportional gain 1 (KP1)	Range: 0.1~9.9 【1.0】
F8.06 PID integration time 1	Range: 0.00~100.0 【10.00s】
F8.07 PID differential time 1	Range: 0.00~1.00 【0.00s】
F8.08 PID proportional gain 2 (KP2)	Range: 0.1~9.9 【1.0】
F8.09 PID integration time 2	Range: 0.00~100.0 【10.00s】
F8.10 PID differential time 2	Range: 0.00~1.00 【0.00s】

The proportional gain (KP) is the parameter that decides the sensitivity of P action in response to the deviation. The bigger the proportional gain KP is, the more sensitive the system acts and the faster the inverter responses.

However, oscillation may easily occur and regulation time extends. When KP is too big, the system tends to instability. When KP is too small, the system will slow, and responses lag.

Use integration time to decide the effect of integral action. The longer the integration time, the slower the response, and the worse the ability of control external disturbance variation. The smaller the integration time is, the stronger the integral take effect. The smaller integration time can eliminate the steady state error and improve control precision, fast response. However, oscillation may easily occur, and the system stability decrease, if the integration time is too small.

Differential time define the effect of differential action. The bigger differential time can attenuate the oscillation caused by P action more quickly when deviations occurs and short the regulation time. However, if differential time is too big, oscillation may occur. If the differential time is small, the attenuation effect will be small when deviations occur and the regulation time is longer. Only the right differential time can reduce regulation time.

Note:

AD300 inverter have two sets of PID parameters, determined by F8.11 .The default parameters is the first group PID parameters.

F8.11 PID parameters switching	Range: 0~2 【0】
---------------------------------------	-----------------------

- 0: No switching, use the first group parameters
- 1: Switching by terminal, to defined the multi-function terminals to switch two groups of PID parameters.
- 2: Auto-switching by deviation, Reffer to the F8.12, F8.13 instructions.

F8.12 Deviation 1 using PID switching	Range: 0.0~999.9 【20.0】
--	--------------------------------

F8.13 Deviation 2 using PID switching	Range: 0.0~999.9 【80.0】
--	--------------------------------

When the two groups of PID parameters automatically switch through the deviation of setting value and feedback value, figure 6-22 shown the details.

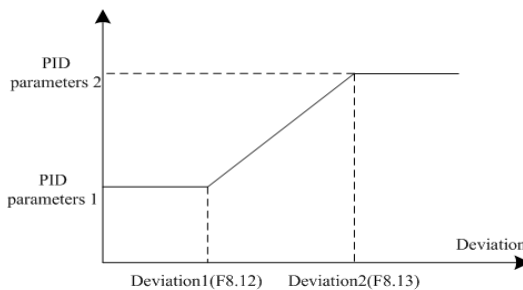

Figure 6-22 PID parameters switching automatically

F8.14 PID delay time constant	Range: 0.00~100.0s 【0.0s】
--------------------------------------	----------------------------------

The instructions of PID control frequency output delay time setting.

F8.15 Deviation limit	Range: 0.0~999.9s 【0.2】
-----------------------	-------------------------

When the deviation of setting value and feedback value lie in a allowed range, PID regulator stop adjustment. The proper Settings of this function will help both the system output accuracy and stability.

F8.16 PID output positive limit	Range: 0.00~300.0Hz 【50.00Hz】
F8.17 PID output negative limit	Range: 0.00~300.0Hz 【0.00Hz】

The two parameters are used to limit the output range of the PID regulator. When frequency set in single PID setting mode, you should adjust the negative limit of the PID for reverse, e.g. setting F8.17=30.00Hz for reverse at 30.00Hz; if the PID is combined with other frequency setting, you should adjust both the positive and negative limits according to the actual operating conditions. For example, if you want to let the frequency fined at +5Hz based on the value set by A11, you should set F8.16=F8.17=5.0Hz.

F8.18 PID preset frequency	Range: 0.00~300.0Hz 【0.00Hz】
F8.19 Hold time of PID preset frequency	Range: 0.0~3600s 【0.0s】

When the PID operation is start, the frequency will ramp up to the PID preset frequency (F8.18) within the Acc time, and then the inverter will start PID operation after operating at the PID preset frequency for a certain time (defined by F8.19), as shown in Fig.6-23.

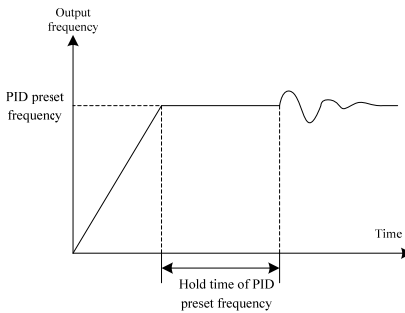

Fig. 6-23 PID preset frequency operation

Note:

If you do not need the preset frequency function, set the preset frequency =0.

F8.20 Enable dormancy	Range: 0~1 【0】
-----------------------	----------------

0: Disabled

1: Enabled

F8.21 Dormancy delay	Range: 0~999s 【120s】
F8.22 Dormancy threshold	Range: 0.00~300.0Hz 【20.00Hz】
F8.23 Awakening threshold	Range: 0.0~999.9 【5.0】

When the output frequency is lower than the dormancy valve and at continues dormancy delay, PID enter the dormant state, the output frequency goes to 0HZ. The inverter will quit the dormant state if PID feedback value lower than Awakening threshold.

6.10 Group F9 Multi-step speed and PLC

F9.00 Multi-step frequency 1	Range: 0.00~Max frequency 【5.00Hz】
F9.01 Multi-step frequency 2	Range: 0.00~Max frequency 【10.00Hz】
F9.02 Multi-step frequency 3	Range: 0.00~Max frequency 【15.00Hz】
F9.03 Multi-step frequency 4	Range: 0.00~Max frequency 【20.00Hz】
F9.04 Multi-step frequency 5	Range: 0.00~Max frequency 【30.00Hz】
F9.05 Multi-step frequency 6	Range: 0.00~Max frequency 【40.00Hz】
F9.06 Multi-step frequency 7	Range: 0.00~Max frequency 【50.00Hz】

Define Multi-step frequency respectively, which can be used in Multi-step speed running and simple PLC running.

For Multi-step speed running, Multi-step speed frequency can be selected through Multi-step command. And when the inverter chooses PLC operation, Multi-step speed frequency will be set by parameter of PLC. As shown in Fig.6-23.

F9.07 PLC running mode	Range: 0~2 【0】
------------------------	-----------------------

0: Single cycle 1

The inverter stops automatically after one cycle of operation and will start when receiving RUN command again.

1: Single cycle 2 (holding the final value)

The inverter will hold the operating frequency and direction of last step after completing one cycle of operation.

2: Continuous operation

The inverter will start next cycle of operation automatically after completing one cycle of PLC operation until receiving STOP command.

F9.08 PLC restarting mode	Range: 0~1 【0】
---------------------------	-----------------------

0: Restart from first step

If the inverter stops during PLC operation because of receiving STOP command or fault, or power loss, it will restart from the first step after restarting.

1: Continue from the step where the inverter stops

When the inverter stops during PLC operation because of receiving STOP command or fault, it will record the operating time and will continue from the step where the inverter stops, and restart at the frequency defined for this step.

F9.09 PLC status saving selection	Range: 0~1 【0】
-----------------------------------	-----------------------

If F9.09 is set to 1, the PLC operating parameters such as the PLC operating step and PLC operating time will be

saved when power loss.

0: Not save

1: save

F9.10 Unit of step time	Range: 0~1 【0】
-------------------------	-----------------------

Define the unit of PLC running time.

0: Second

1: Minute

F9.11 PLC running timing T1	Range: 0.1~3600 【20.0】
F9.12 PLC running timing T2	Range: 0.0~3600 【20.0】
F9.13 PLC running timing T3	Range: 0.0~3600 【20.0】
F9.14 PLC running timing T4	Range: 0.0~3600 【20.0】
F9.15 PLC running timing T5	Range: 0.0~3600 【20.0】
F9.16 PLC running timing T6	Range: 0.0~3600 【20.0】
F9.17 PLC running timing T7	Range: 0.1~3600 【20.0】

Configure the running time of each PLC running step. If the running time of the step is set to 0, the inverter will skip the step and run at the next step, as shown in Fig 6-23.

F9.18 PLC Step T1 program running setting	Range: 1F/r~4F/r 【1F】
F9.19 PLC Step T2 program running setting	Range: 1F/r~4F/r 【1F】
F9.20 PLC Step T3 program running setting	Range: 1F/r~4F/r 【1F】
F9.21 PLC Step T4 program running setting	Range: 1F/r~4F/r 【1F】
F9.22 PLC Step T5 program running setting	Range: 1F/r~4F/r 【1F】
F9.23 PLC Step T6 program running setting	Range: 1F/r~4F/r 【1F】
F9.24 PLC Step T7 program running setting	Range: 1F/r~4F/r 【1F】

F9.18~F9.24 are used to configure the direction and Acc/Dec time of each PLC running step. There are total 8 kinds of combinations could be selected, please refer to Table 6-9 for the details.

Table6-9 Settings of PLC step

Combination content	Acc/Dec time	Direction
1F	Acc/Dec time 1	F: Forward
1r		r: Reverse
2F	Acc/Dec time 2	F: Forward
2r		r: Reverse
3F	Acc/Dec time 3	F: Forward
3r		r: Reverse
4F	Acc/Dec time 4	F: Forward
4r		r: Reverse

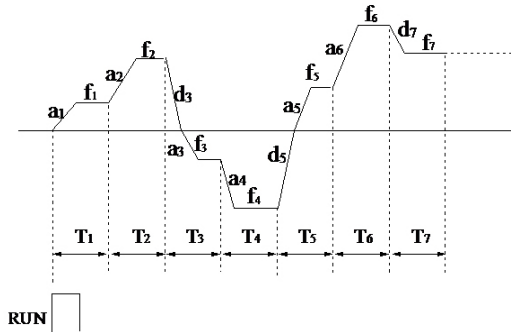

Fig.6-24 Simple PLC running

Note :

In Fig.6-24, $f_1 \sim f_7$, $a_1 \sim a_7$, $d_1 \sim d_7$ and $T_1 \sim T_7$ respectively correspond to step frequency, Acc Time, Dec Time and running time.

F9.25 Record of PLC steps	Range: 1~7 【0】
F9.26 Running time of current step	Range: 0.0~3600 【0】

F9.25 records the steps that the PLC currently operating at.

F9.26 records the operating time of the step that the PLC currently running at.

F9.27 Multi-step frequency 8	Range: 0.00~Max frequency 【50.00Hz】
F9.28 Multi-step frequency 9	Range: 0.00~Max frequency 【50.00Hz】
F9.29 Multi-step frequency 10	Range: 0.00~Max frequency 【50.00Hz】
F9.30 Multi-step frequency 11	Range: 0.00~Max frequency 【50.00Hz】
F9.31 Multi-step frequency 12	Range: 0.00~Max frequency 【50.00Hz】
F9.32 Multi-step frequency 13	Range: 0.00~Max frequency 【50.00Hz】
F9.33 Multi-step frequency 14	Range: 0.00~Max frequency 【50.00Hz】
F9.34 Multi-step frequency 15	Range: 0.00~Max frequency 【50.00Hz】

Define Multi-step frequency respectively, which can be used in Multi-step speed running. And multi-step speed frequency can be selected through Multi-step command.

F9.35 Multi-step frequency 1 selection for PLC	Range: 0~4 【0】
F9.36 Multi-step frequency 2 selection for PLC	Range: 0~4 【0】

Define Multi-step 1 & 7 frequency source.

- 0**: Multi-step digital setting **1**: AI1 terminal **2**: AI2 terminal
- 3**: keyboard potentiometer **4**: Pulse input

6.11 Group FA Swing Frequency Operating

The swing frequency operating means that the output frequency of the inverter swings up and down with the setup frequency as the center. The trace of running frequency at the time axis is shown As in Figure 6-25, of which the swing amplitude is set by FA-00. When FA-00 is set to 0, indicating the swing amplitude is 0, the swing frequency is disabled.

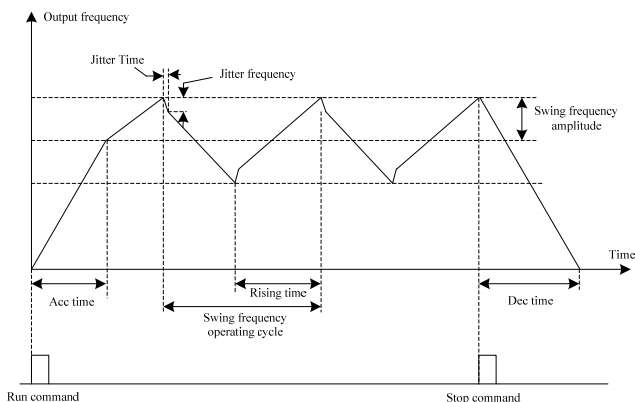

Fig.6-25 swing frequency operation Diagram

FA.00 Swing frequency amplitude	Range: 0.0~50% 【0.0%】
FA.01 Jitter frequency	Range: 0.0~50%(Relative to FA.00) 【0.0%】
FA.02 Jitter Time	Range: 5~50ms 【5ms】
FA.03 Swing frequency operating cycle	Range: 0.1~999.9s 【10.0s】
FA.04 Swing ratio	Range: 0.1~10.0 【1.0】

Swing frequency amplitude: The range of swing operating frequency.

Swing frequency operating cycle: A cycle of swing frequency operation.

Swing ratio: UP time ÷ DOWN time.

FA.05 Swing setupmode	Range: 0~1 【0】
-----------------------	-----------------------

This parameter is used to select the benchmark quantity of the swing amplitude.

0: Relative to the central frequency

It is variable swing amplitude system. The swing amplitude varies with the central frequency (setup frequency).

1: Relative to the maximum frequency

It is fixed swing amplitude system. The swing amplitude is fixed.

FA.06 Reserved	Range: Reserved
FA.07 Reserved	Range: Reserved

6.12 Group FB Fixed-length

FB.00 Preset length	Range: 0~65530 【0】
FB.01 Actual length	Range: 0~65530 【0】
FB.02 number of pulse per-unit	Range: 0.1~6553.0 【100.0】

The preset length (PB.00), actual length (PB.01) and number of pulse per-unit (FB.02) are mainly used for fixed-length control. The length is calculated via the pulse signal input by the digital input terminal, which needs to set the corresponding input terminal to length count input terminal. And input terminal X4 or X5 is usually used when the pulse frequency is relatively high.

Actual length = number of count pulses ÷ number of pulse per-unit.

When the actual length FB.01 exceeds the preset length FB.00, the multifunctional digital output terminal set to “length arrival terminal” will output indication signal.

6.13 Group FC Protection and Fault Parameters

FC.00 Motor overload protection mode selection	Range: 0~2 【0】
--	----------------

0: Disabled

The overload protection is disabled. Be careful to use this function because the inverter will not protect the motor when overload occurs.

1: Common motor (with low speed compensation)

Since the cooling effects of common motor deteriorates at low speed (below 30 Hz), the motor’s overheat protecting threshold should be lowered, which is called low speed compensation.

2: Variable frequency motor (without low speed compensation)

The cooling effects of variable frequency motor are not affected by the motor’s speed, so low speed compensation is not necessary.

FC.01 Electro thermal protective value	Range: 20~110% 【100%】
--	-----------------------

In order to apply effective overload protection to different kinds of motors, the Max output current of the inverter should be adjusted, as shown in Fig.6-26.

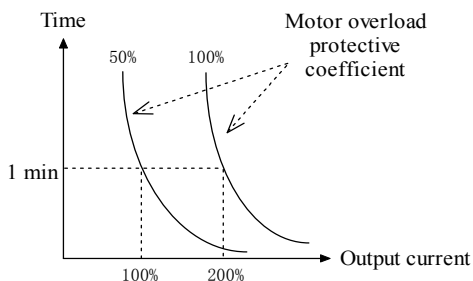

Fig 6-26 Motor overload protection curve

Motor overload protection coefficient calculates:

Motor overload protection coefficient = $\frac{\text{the max allowed current of load}}{\text{rated output current of inverter}} \times 100\%$

Generally, the Max load current is the motor rated current.

FC.02 Pre-overload detection Level	Range: 30.0~200.0% 【160.0%】
FC.03 Pre-Overload detection time	Range: 0.0~80.0s 【60.0s】

FC.02 defines the current threshold for overload pre-alarm protection. The setting range is a percentage value of rated current.

FC.03 defines the time during which the inverter current exceeds FC.02. If the pre-overload status remains after this period, the inverter will output pre-alarm signal (OLP2).

FC.04 Current amplitude limit selection	Range: 0~2 【1】
---	-----------------------

Over current stall function selection.

During the Acc/Dec running, if the actual current exceeds the “Current amplitude limiting level” (PC.04), the inverter stops the Acc/Dec process till the current is lower than the point.

In the inverter’s constant speed operating process, if PC.04 is set to 2, when the actual current exceeds “Current amplitude limiting level” (PC.05), the inverter will reduce output frequency till the current lower than the point. Then the inverter will return to the original work state.

- 0: Invalid
- 1: Valid during Acceleration and deceleration, invalid in constant speed Operation
- 2: Valid

FC.05 Current amplitude limiting level	Range: Type G: 80.0~200.0% 【160.0%】 Type P: 60.0~150.0% 【120.0%】
--	---

Define the limiting level of stall over current protection.

FC.06 Over voltage stall function selection	Range: 0~2 【1】
---	-----------------------

Over voltage stall function selection.

In Inverter’s Acc/Dec process, if the bus voltage exceeds the stall overvoltage point defined by PC.06, the inverter will stop changing its output frequency.

In the inverter’s constant speed operating process, if the bus voltage exceeds the stall overvoltage point, the inverter will raise its output frequency. The Acc/Dec time is defined by Acc/Dec time 4.

- 0: Invalid
- 1: Valid during Acceleration and deceleration, invalid in constant speed Operation
- 2: Valid

FC.07 Over-voltage point at stall	Range: 110.0~150.0% Bus voltage 【140.0%】
-----------------------------------	---

Define the stall over voltage point.

FC.08 Input phase loss detection level (SPI)	Range: 1~100% 【20%】
FC.09 Input phase loss detection delay time	Range: 2~255s 【10s】

Input phase loss detection function can detect loss of input phase or a serious imbalance in the three-phase input, in order to protect inverter. If the input phase loss detection is hypersensitive, you can appropriately increase the detection level (FC.08) and detection delay time (FC.09). Conversely, decrease the detection level (FC.08) and detection delay time (FC.09). When FC.08 is set to 100%, there is no input phase's loss protection.

FC.09 Output phase loss detection level (SPO)	Range: 0~100% 【0%】
FC.10 Output phase loss detection delay time	Range: 0.0~10.0s 【0.2s】

Output phase loss detect function can detect loss of output phase or a serious imbalance in the three-phase output, in order to protect inverter and motor. If the output phase loss detection is hypersensitive, you can appropriately decrease the detection level (FC.09) and increase the detection delay time (FC.10). Conversely, increase the detection level (FC.09) and decrease detection delay time (FC.10). When FC.09 is set to 0%, there is no output phase's loss protection.

FC.11 Fault auto reset times	Range: 0~10 【0】
FC.12 Reset interval	Range: 2.0~20.0s 【5.0s】

Auto reset function can reset OC and OU, these two faults in auto reset times (FC.11) and interval (FC.12). During the reset interval, the inverter stops output and runs at zero-speed. It will restart according to start mode after the reset interval. When FC.11 is set to 0, it means "auto reset" is disabled and the protective function will be activated in case of fault.

Note :

Only OC, OU can be auto reset.

6.14 Group FD Communication Parameters

Fd.00 communication enabled	Range: 0~1 【0】
-----------------------------	-----------------------

Disable 485 communication function can effectively reduce the interference, when no use MODBUS communication.

0: Disabled

1: Enabled

Fd.01 Local address	Range: 1~247 【1】
---------------------	-------------------------

Define the inverter's communicating address. The address set to 0 is for the broadcast address to realize the PC broadcasting; When the machine address is 247, this machine will serve as the host on the network to broadcast on other machine to achieve synchronization function.

note :

- 1 . Local address should be the unique; it is the foundation to realize point-to-point communication between the host and inverter.
- 2 . When the inverter is the host, each broadcast time intervals is the responding delay (Fd.05).With too short response delay time may lead to communication error.

Fd.02 Baud rate	Range: 0~5 【3】
-----------------	----------------

Select the baud rate of serial communication. The master and the slave must keep the same baud rate setting. Otherwise, they can not communicate normally. Higher baud rate could have a faster communication.

- 0: 1200bpS
- 1: 2400bpS
- 2: 4800bpS
- 3: 9600bpS
- 4: 19200bpS
- 5: 38400bpS

Fd.03 Data format	Range: 0~2 【0】
-------------------	----------------

Choose the way of parity. The master and the slave must keep the same data format setting. Otherwise, they can not communicate normally.

- 0: Even parity check
- 1: Odd parity check
- 2: No parity check

Fd.04 Communication Time over detection	Range: 0.0~100.0s 【0.0s】
---	--------------------------

Set communication timeout detecting time. After the establishment of communications, If in detect time, no normal data is transmit, the inverter will stop immediately and displays Error. If there is If Pb.03 is set to zero, this function is disabled.

Fd.05 Response delay	Range: 0~500ms 【0ms】
----------------------	----------------------

As the slave, this parameter refers to the time from inverter receiving the host PC command to returning response frame to it. And it defines the interval of each broadcast, as the host.

6.15 Group FE Keyboard and Display

FE.00 LCD Language selection	Range: 0~1 【0】
------------------------------	----------------

- 0: Chinese
- 1: English

Note:

This function is only effective for the panel with LCD screen. And the LED panel only displays segment code of characters and digits.

FE.01 MFK Key function selection	Range: 0~4 【0】
----------------------------------	----------------

- 0: MFK inactive
 - 1: JOG running
 - 2: Direction switch key
- Used to start Jog running, the direction is set by function code F0.17.

MFK key is used to switch the running direction between forward and reverse. It is equivalent to modify F0.17, but it will not be saved when power lost.

3: UP/DOWN clear

Used to Clear the frequency set by external terminals (UN/DOWN) , this is equal to the function of terminal “UP/DOWN clear command”。

4: Running command switch

MFK key is used to switch the run command mode between keyboard control and remote command control (terminal command channel or serial communication command channel). And the current run command mode must be terminal or communications, otherwise this button is invalid

FE.02 STOP key function selection	Range: 0~3 【2】
--	-----------------------

This parameters used to define the STOP key functions, including stop, and fault reset.

0: Active only in the keyboard control mode

1: STOP key stop function active in the terminal/communication control mode

2: STOP key fault reset function active in the terminal/ communication control mode

3: STOP key stop and fault reset function active in the terminal/ communication control mode

FE.03 Output frequency (Hz) (before compensation)	Range: 0~3 【2】
FE.04 Output frequency (Hz) (Actual)	Range: 0~3 【0】
FE.05 Reference frequency (Hz, flashes)	Range: 0~3 【1】
FE.06 Output current(A)	Range: 0~3 【2】
FE.07 Bus voltage (V)	Range: 0~3 【0】
FE.08 Output voltage (V)	Range: 0~3 【0】
FE.09 Output torque (%)	Range: 0~3 【0】
FE.10 Reference torque (% , flashes)	Range: 0~3 【0】
FE.11 Rotate speed (r/min)	Range: 0~3 【0】
FE.12 Reference speed (r/min flashes)	Range: 0~3 【0】
FE.13 Output power (kW)	Range: 0~3 【0】
FE.14 AI1 (V)	Range: 0~3 【0】
FE.15 AI2(V)	Range: 0~3 【0】
FE.16 Analog PID feedback	Range: 0~3 【0】
FE.17 Analog PID feed	Range: 0~3 【0】
FE.18 Terminal status (no unit)	Range: 0~3 【0】
FE.19 Actual length	Range: 0~3 【0】
FE.20 Preset length	Range: 0~3 【0】
FE.21 Linear speed (m/s)	Range: 0~3 【0】
FE.22 External counting value (no unit)	Range: 0~3 【0】

This function parameters defines the display in the downtime and operation monitoring condition。

0: No display

1: Display only in stop process

2: Display only during running

3: Display in stop and run

Explanation :

- ◆ In stop process, if no parameter is set to show in monitor state, reference frequency will be displayed. Otherwise, during running, the output frequency (before compensation) will be displayed.
- ◆ The unit light for analog PID feed and analog PID feedback is “Hz” + “A”, and if switch to display analog PID feed, the light will lit up and flashing.
- ◆ The terminal status are shown by four LED units without unit indicator, the specific meaning shown in figure 6-26.

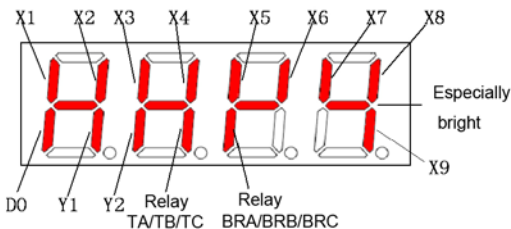

Fig6-26 Terminal status diagram

6.16 Group FF Running History Record

FF.00 Type of latest fault	Setting range: 0~22 【NULL】
FF.01 Output frequency at latest fault	Setting range: 0~Frequency upper limit 【0.00Hz】
FF.02 Reference frequency at latest fault	Setting range: 0~Frequency upper limit 【0.00Hz】
FF.03 Output current at latest fault	Setting range: 0~2* inverter rated current 【0.0A】
FF.04 Bus voltage frequency at latest fault	Setting range: 0~1000V 【0V】
FF.05 Running status at latest fault	Setting range: 0~3 【0】
FF.06 Fault history 1 (Last One)	Setting range: 0~22 【NULL】
FF.07 Fault history 2	Setting range: 0~22 【NULL】

Memorize the types of the last 3 faults (See “chapter 7: fault/ alarm information table” for the details of faults). And record the output frequency, reference frequency, output current, DC bus voltage and running status of the latest fault for troubleshooting.

FF.08 Total power on time	Range: 0~65530h 【0】
FF.09 Total running time	Range: 0~65530h 【0】

The total boot time and runtime accumulated automatically by Inverter.

FF.10 Reserved	Range: 0~9999 【0】
----------------	--------------------------

FF.11 Soft Software version number of control board	Range: 1.00~10.00 【1.00】
FF.12 Non-standard version number of software	Range: 0~255 【0】

Software version number and non-standard version number of product represent the software type.

6.17 Group FP Protection Parameters

FP.00 User password	Range: 0~9999 【0】
---------------------	--------------------------

Any non-zero number can be set to enable password protection function. The preset password is required to access Group PF. Otherwise all parameters of Group PF cannot be accessed.

0000: Clear the previous setup user password and disable the password protection function.

FP.01 Parameter write-in protection	Range: 0~2 【0】
-------------------------------------	-----------------------

0: All parameters are allowed modifying

1: Only FP.01 and FP.03 can be modified

In addition to this function code and FP.03, all parameters can be read but can not be modified.

2: All parameters aren't allowed read

In addition to this function code and FP.03, all parameters shows as "0000" and can not be modified, this can prevent irrelevant person to check .

FP.02 Parameter initialization	Range: 0~2 【0】
--------------------------------	-----------------------

0: No operation

1: Clear fault history

When FP.02 is set to 1, the fault records of FF.00~FF.07 will be cleared.

2: Restore to defaults

When FP.02 is set to 2, the parameters (except running history and user password) are restored to defaults.

FP.03 Parameter copy	Range: 0~2 【0】
----------------------	-----------------------

0: No action

1: Parameters download

According to the type parameter of the operation panel preservation (whether has motor parameters, etc), automatically download to the control board.

2: Parameters upload (except motor's parameters)

All parameters will upload to EEPROM of operation panel except "Running history record" (Group FF) and "motor parameters" (Group F5).

3: Parameters upload (all parameters)

All parameters will upload to the EEPROM of operation panel except "Running history record" (Group FF).

FP.04 Parameter upload protection	Range: 0~1 【0】
-----------------------------------	-----------------------

0: Protection enabled

When the operation panel has store effective parameters, uploading parameters to operation panel is invalid

and submitted “copy fault”.

1: Protection disabled

Whether the operation panel store effective parameters, as long as the parameters upload, operation panel will store the parameters from control panel.

FP.05 G/P model selection	Range: 0~1 【0】
---------------------------	-----------------------

0: Type G

1: Type P

Chapter 7 Fault information and solutions

7.1 Fault information and solutions.

Once a fault is detected, the AD300 series of frequency converter would immediately block PWM output and enter the fault protection state; meanwhile TRIP on the keyboard would spark and the digital control area display the fault code. At this point one must identify the course of failure and its corresponding solutions according to the method suggested in this section, if it does not work, please contact us immediately. The series of frequency converter has 22 kinds of faults, which is shown together with their respective solutions in Table 7-1.

Table 7-1 fault diagnosis and its solutions

Fault code	type	Possible reasons	solutions
Uu1	Bus Under voltage during running	1.Low voltage grid	1.Check the input power source.
OC1	Over current in Acc-processt	1.Acceleration time is too short 2 .Low voltage grid 3.Small power convertor	1. Increase the acceleration time. 2. Check the input power source. 3. Choose the frequency converter with higher capacity.
OC2	Over current in De-cprocess	1 .Deceleration time is too short 2 .Large load inertia 3 .Small power convertor	1.Increase the acceleration time. 2. Add suitable brake packages. 3. Choose the frequency converter with higher capacity.
OC3	Over current inconstant-speed Operation	1 .Abnormal Load mutation 2.Low voltage grid 3.0Small power convertor 4.The encoder suddenly disconnected when the Closed Loop Vector is working	1. Check the load 2. Check the input power source. 3. Choose the frequency converter with higher capacity. 4. Check the encoder and its wiring.
Ou1	Over Voltage in Acceleration process	1.Acceleration time is too short 2.Uncommon power of the grid	1. Increase the acceleration time 2. Check the input power source.
Ou2	Over voltage in deceleration process	1.Deceleration time is too short 2.Large load inertia	1. Increase the acceleration time 2. Add suitable brake packages.
Ou3	Over voltage in constant speed Operation	1.Uncommon power of the grid 2.Large load inertia	1. Check the input power source. 2. Add suitable brake packages.
GF	Ground Fault	1.The output side has a relatively short circuit.	1.Check whether the electric motor insulation is weakening. 2. Check whether the wiring between the frequency converter and the electric motor is damaged.
SC	Load short-circuit	1.The converter and the motor wiring have short circuit 2.Damage of the contravariant module	1. Check whether the electric motor coil is short circuit. 2. Ask for the services from manufactures.
OH1	Radiator over heat	1.Too high temperature of the environment 2.The damage of air fan 3.The passage of fan is blocked	1. Lower the working temperature. 2. Change the fan 3. Clear the ail channel.

Fault code	type	Possible reasons	solutions
OL1	Motor overload	<ol style="list-style-type: none"> 1. Low voltage grid 2. Rated current of electrical machine sets wrongly 3. The Curve of V/F is not fit 4. The normal electrical machine always work with a low speed load 5. The mutation of load is too high or blocked shift by electronically machine 6. The motor power is too lower 	<ol style="list-style-type: none"> 1. Check the input power source. 2. Check whether the electric motor's rated current is correctly set up. 3. Adjust the V/F curve and torque pull-up. 4. Choose the special electric motor. 5. Check the load and whether the electric motor's rotor is locked. 6. Select Appropriate capacity Motor and inverter
OL2	Inverter overload	<ol style="list-style-type: none"> 1. Low voltage grid 2. Too heavy load 3. Accelerates excessively quickly 4. Restart the turning electronic machine 	<ol style="list-style-type: none"> 1. Check the input power source. 2. Select bigger capacity inverter. 3. Increase the acceleration time 4. Avoid starting during the motor rotation.
EF0	Communication fault	<ol style="list-style-type: none"> 1. Baud rate and parity checksum is set uncorrected 2. Be breaked for long time when communication 	<ol style="list-style-type: none"> 1. Check the communication parameters is correct. 2. Check the interface wiring.
EF1	External terminal fault	<ol style="list-style-type: none"> 1. Faults comes from external control circuit 	<ol style="list-style-type: none"> 1. Check the input from external devices.
SP1	Input phase failure or Unbalance	<ol style="list-style-type: none"> 1. Input R,S,T have phase loss or imbalance 	<ol style="list-style-type: none"> 1. Check input voltage
SPO	Output phase failure or Unbalance	<ol style="list-style-type: none"> 1. There is lack of U,V,W when output 2. There is a big unbalance of output 	<ol style="list-style-type: none"> 1. Check U,V,W input wire. 2. Check the load
CCF	Transmission between the inverter and keyboard cannot be established	<ol style="list-style-type: none"> 1. Connection cable between keyboard and control panel is broken 	<ol style="list-style-type: none"> 1. Check the connection cable between keyboard and control panel
bCE	Brake unit fault	<ol style="list-style-type: none"> 1. The braking line or braking pipe is brokem 2. brake resistor is too lower 	<ol style="list-style-type: none"> 1. Check the brake unit, change the brake pipe. 2. Choose the suitable braking resistor.
PCE	Parameter copy Error	<ol style="list-style-type: none"> 1. There is some disturbing caused by the two long connecting line between Keyboard and control board when copy the parameter 2. There is some conflict between the parameter of keyboard and the parameter of transducer when download the parameter 	<ol style="list-style-type: none"> 1. Shorten the cable length between Keyboard and control board in order to reduce interference. 2. During download, make sure the parameters in keyboard is matched with that of in the frequency converter.
IDE	IDE Hall current detection fault	<ol style="list-style-type: none"> 1. The galvanoscopy of transducer or the damage of the cell of hall 	<ol style="list-style-type: none"> 1. Ask for sevice
ECE	PG fault	<ol style="list-style-type: none"> 1. Turn the sign line of encoder contrary 2. The broken of encoder sign line 3. The damage of encoder 4. electronic machine and encoder work in a inconformity direction 	<ol style="list-style-type: none"> 1. Check whether the encoder signal is correctly connected. 2. Check whether the encoder wiring is broke. 3. Change the encoder. 4. Change the encoder direction (F3.16) or alter the sequence of the side line in electric motor.

7.2 Warning information

Once a fault is detected, the AD300 series of frequency converter would immediately block PWM output and enter the fault protection state and TRIP on the keyboard would spark and the digital control area display the fault code, when alarming the frequency converter can continue to work, once the alarm disappears the converter would automatically return to the previous display status. Specific warning information is shown in Table 7-2

Table 7-2 warning information

Warning Code	Type	Discription
Uu	Warning of undervoltage	The bus voltage is below the voltage point
OLP2	The warn about overload of encoder	Operating current exceeded the converter overload detection level and maintained more than overload detection time
OH2	Warns caused by the too high temperature of radiator	Temperature in the radiator higher than the OH2 standard
SF3	Setting function code unreasonable	Output terminal DO, Y1, Y2 does not simultaneously select No.10 function

7.3 The general fault diagnosis and solutions

Please try to analysis according to the following way when you meet some accident using the encoder.

serial number	abnormal occurrence	Possible reasons	Method
1	The keyboard can't display when power on	1. Whether there is power supply 2. The keyboard or the connecting cable between keyboard and control board is damaged. 3. The inverter is damaged in the internals.	1. Check the input power supply 2. Change connecting cable between keyboard and control board 3. Ask for service
2	Motor don't rotate when the inverter is running	1.The motor is damaged or block up 2.The conflict of the setting prevented reverse and the works direction 3. The frequency reference is zero. 4.The wire of motor maybe short-cut	1. replace the electric motor or rule out the mechanical failure. 2.set up approval of reverse or change the operation direction. 3.check the given signal of the frequency. 4.check the electric motor wiring.
3	the electric works with a opposite direction	1.The connecting lines of electric motor with a wrong sequence	1. alter the sequence of the side line in electric motor. 2.adjust the function code F0.017
4	Electric motor shakes too heavy	1.mechanical resonance 2.The leg of motor is not stable 3.The balance outputting between the three phase	1. adjust the machine 2. adjust the under-classis. 3.check the load.
5	The noise of motor is too loud	1.Lubrication is not good or bearing wear 2.carrier frequency is too low	1. repair or replace the electric motor. 2.Increase the carrier frequency of the frequency converter.

Chapter 8 Routine Repair and Maintenance

The application environment (such as temperature, humidity, dust and powder, wool, smoke and oscillation), burning and wearing of internal devices and other factors may increase the possibilities of inverter failure. To reduce the failures and prolong the service life the inverter, it needs to conduct routine repair and periodic maintenance.



Note:

1. Only the personnel receiving professional training can dismantle and replace the inverter components.
2. Before inspection and maintenance, please make sure that the power supply to the inverter has been shut down for at least ten minutes or the CHARGER indicator is OFF, or there may be risks of electric shock..
3. Do not leave metal components and parts in the inverter, or it may damage the equipment.

8.1 Routine Maintenance

The inverter shall be used under the allowable conditions as recommended in this manual and its routine maintenance shall be conducted as per the table below.

Item	Inspection	Contents	Inspection
Operating Environment	Temperature	Thermometer	-10 ~ +40°C Derated at 40 to 50°C, and the rated output current shall be decreased by 1% for every temperature rise of 1°C.
	Humidity	Humidimeter	5 ~ 95%, no condensing
	Dust, oil, water and drop	Visual check	There are no dust, oil, water and drop.
	Vibration	Special test instrument	3.5mm, 2~9Hz; 10m/s ² , 9~200Hz; 15m/s ² , 200~500Hz
	Gas	Special test instrument, smell check and visual check	3.5mm, 2~ 9Hz; 10m/s ² ,9~ 200Hz; 15m/s ² ,200~ 500Hz
Inverter	Overheat	Special test instrument	Exhaust normal
	Sound	Listen	There is no abnormal sound.
	Gas	Special test instrument	There are no abnormal smell and smoke.
	Physical appearance	Visual check	The physical appearance is kept intact.
	Heatsink fan ventilation	Visual check	There are no fouling and wool that block the air duct.
	Input current	Amperemeter	In the allowable operating range. Refer to the nameplate.
	Input voltage	Voltmeter	In the allowable operating range. Refer to the nameplate.
	Output current	Amperemeter	In the rated value range. It can be overloaded for a short while.
	Output voltage	Voltmeter	In the rated value range.
Motor	Overheat	Special test instrument and smell.	There are no overheat fault and burning smell.
	Sound	Listen	There is no abnormal sound.
	Vibration	Special test instrument	There is no abnormal oscillation.

8.2 Periodic Maintenance

It needs to perform periodic inspection on the inverter once every three to six months according to the application environment and work conditions.

Item	Inspection	Contents	Inspection
Inverter	Main circuit terminal	Screwdriver/sleeve	The screws are tightened and the cables are kept well.
	PE terminal	Screwdriver/sleeve	The screws are tightened and the cables are kept well.
	Control circuit terminal	Screwdriver	The screws are tightened and the cables are kept well.
	Control circuit terminal	Screwdriver and hands	Connection is firm and reliable.
	Expansion card connector	Screwdriver and hands	Connection is firm and reliable.
	Mounting screws	Screwdriver/sleeve	The screws are tightened.
	Cleaning the dusts and powders	Cleaner	There are no dusts and wools.
	Internal foreign objects	Visual check	There are no foreign objects.
Motor	Insulation test	500VDC megameter	Normal

8.3 Component Replacement

Different types of components have different service lives. The service lives of the components are subject to the environment and application conditions. Better working environment may prolong the service lives of the components. The cooling fan and electrolytic capacitor are vulnerable components and shall be conducted routine inspection as per the table below. If any fault occurs, please conduct immediate replacement.

Vulnerable components	Damage Causes	Solutions	Items for Routine Inspection
Fan	Bearing wear, blade aging	Change	The fan blade has no cracks and rotates normally. The screws are tightened.
Electrolytic capacitor	Ambient temperature is relatively high and electrolyte volatilizes.	Change	There are no electrolyte leakage, color change, crack and shell inflation. The safety valve is normal. Static capacity is equal to or higher than the initial value times 0.85.



Note:

When the inverter is stored for a long period of time, power connection test shall be conducted once within two years and last at least five hours. It can use voltage regulator to gradually increase the value to the rated value when power connection is performed.

8.4 Warranty

The inverter's warranty period is of 18 months (from date of purchase), during which the company would offer

free repair or replacement if the fault or damage occurred under normal use.

During the warranty period, the maintenance will be charged a reasonable cost due to fault caused by the following reasons.

- ① fault caused by not following the operating manual or exceeding the operating standards.
- ② fault caused by without permission to repair or modify the converter.
- ③ fault caused by using the converter for non-normal function, such as the wiring errors.
- ④ fault caused by fire, salt corrosion, gas corrosion, earthquakes, storms, floods, lightning, abnormal voltage, or other force majeure causes damage to the machine.

Appendix A Modbus Communication Protocol

The inverter support Modbus protocol, RTU format, Broadcast address 0, slave address “1-247”. Interface mode: RS485: Asynchronous, half duplex.

1. Protocol Format

Start	The initial space of frame is 3.5 characters or above
Slave address	1~247
Function Code	03: Read parameters from slave 06: Write parameters to slave 08: Loopback Test
Data(N)	2×N data, this is the main content of modbus communication.
.....	
Data(0)	
Error check	CRC check
End	The End space of frame is 3.5 characters or above

2. Function Code and Data

Function Code 03H: Reads parameters and status words of one parameters of the inverter.

Example: Read parameter(register address: 0100H) from the slave 1, the format is as follows:

The Master Request

Slave address	01H
Function code	03H
Register address Hi	01H
Register address Lo	00H
Number of registers Hi	00H
Number of registers Lo	01H
CRC Hi	85H
CRC Lo	F6H

The Slave Response

Slave address	01H
Function code	03H
Byte Count	02H
Data Hi	00H
Data Lo	01H
CRC Hi	79H
CRC Lo	84H

Function Code 06H: Write parameters and status words of one parameters of the inverter.

Example: write parameter(F0.19 register address: 0113H) to the slave 1, the format is as follows:

The Master Request

Slave address	01H
Function code	06H
Register address Hi	01H
Register address Lo	13H
Data Hi	00H
Data Lo	64H
CRC Hi	78H
CRC Lo	18H

The Slave Response

Slave address	01H
Function code	06H
Register address Hi	01H
Register address Lo	13H
Data Hi	00H
Data Lo	64H
CRC Hi	78H
CRC Lo	18H

Function Code 10H: Write parameters and status words of one parameters of the inverter.

Example: write parameter(F0.19 register address: 0113H) to the slave 1, the format is as follows:

The Master Request

Slave address	01H
Function code	10H
Register address Hi	01H
Register address Lo	13H
Number of registers Hi	00H
Number of registers Lo	01H
Byte Count	02H
Data Hi	00H
Data Lo	64H
CRC Hi	B5H
CRC Lo	D8H

The Slave Response

Slave address	01H
Function code	06H
Register address Hi	01H
Register address Lo	13H
Number of registers Hi	00H
Number of registers Lo	01H
CRC Hi	F1H
CRC Lo	F0H

Function Code 08H: The transmitted message is returned unchanged as a response message. This test is used for checking the signal communication between master and slave. The format is as follows:

The Master Request

Slave address	01H
Function code	08H
Register address Hi	00H
Register address Lo	00H
Data Hi	12H
Data Lo	34H
CRC Hi	EDH
CRC Lo	7CH

The Slave Response

Slave address	01H
Function code	08H
Register address Hi	00H
Register address Lo	00H
Data Hi	12H
Data Lo	34H
CRC Hi	EDH
CRC Lo	7CH

If the operation request is rejected, the response will be error code and abnormal function code. Error function code equals to function code +0x80, abnormal code shows the error cause in detail. The format is as follows:

The slave response for the rejected request

Slave address	01H
Function code	83H
Error Code	02H
CRC Hi	C0H
CRC Lo	F1H

Examples for abnormal codes:

Error Code	Definition
01H	Illegal function code: is not 03H,06H,10H,08H
02H	Register address error
03H	Register number error
21H	Data error: beyond data limit
22H	Error when data is written: ·The register is not written when the inverter is running, or write data to the only read-out register address. ·Data is written during EPPROM fault. ·Data is written when data is edited by keypad.
23H	Data is written when the inverter is under voltage.
24H	CRC check error

3. Inverter Register Address Distribution

(1) The corresponding relationship between the function codes of the inverter and the Modbus protocol register address. The bytes at higher orders refer to function code group number + 1, the bytes at lower orders refer to function

code number, express with HEX adecimal. For example, the modbus register address of function code F0.02 is 0102H. The parameters are saved upon power failure when the highest bit of the register adrssess is set. For example, when the regstiger address 8012H is written, the parameter F0.02 is saved to eeprom.

Note: The life of EEPROM is about 100000 times,if change setting frequency frequently, several days or several weeks may damage EEPROM, adopt write RAM, it can avoid to damage EEPROM.

(2) The other parametere register address

Name of Parameters	Register Address	Content	R/W
Reserved	0000H	Reserved	Reserved
Communication Run Command	0001H	0001H: Forward rotation 0002H: Reverse rotation 0003H: Stop 0004H: Coast to stop 0005H: Fault reset	W
Communication Seting	0002H	Range(-10000~10000) Note: Communication Seting is percentage. (-100.00 ~ 100.00%)。 When it 's used to frequeny setting, it's relative to the maximum frequency.When it's used to torque setting, it's relative to the 2*rated torque. When it's used to PID setting or feedback, it's related to the analog input corresponding setup	W/R
Reserved	0003H~001FH	Reserved	Reserved
Inverter Status	0020H	Bit0---1:Run 0: Stop Bit1---1:Reverse rotation 0:Forward rotation Bit2---1:Fault 0:No Fault Bit3---1:Warning 0:No warning Bit4---1:On fault reset 0:no on fault reset	R
Fault Content	0021H	0: NULL 1: Uu1 bus Under voltage fault 2: OC1 over current in acceleration 3: OC2 over current in deceleration 4: OC3 over current in constant speed 5: Ou1 over voltage in acceleration 6: Ou2 over voltage in deceleration 7: Ou3 over voltage in constant speed 8: GF Ground Fault 9: SC Load Short-Circuit 10: OH1 Radiator over heat 11: OL1 Motor overload 12: OL2 Inverter overload 13: EF0 communication fault 14: EF1 external terminal fault 15: SP1 Input phase failure or Unbalance 16: SPO Output phase failure or Unbalance 17: EEP EEPROM Fault 18: CCF Transmission between the inverter and keyboard cannot be established 19: bCE Brake unit fault	R

Name of Parameters	Register Address	Content	R/W
		20: PCE Parameter copy Error 21: IDE Hall current detection fault 22: ECE PG fault	R
Warning Content	0022H	0: No warning 1: uu Bus under voltage warning 2: OLP2Inverter overload warning 3: OH2Inverter overheat warning 4: SF3Output Terminal function selection 10 not reach to 3	R
Runging/Stop Mornitor parameters	0023H	Output frequency	R
	0024H	Frequency reference	R
	0025H	Bus voltage	R
	0026H	Output voltage	R
	0027H	Output current	R
	0028H	Rotate speed of motor	R
	0029H	Output power	R
	002AH	Output torque	R
	002BH	PID reference	R
	002CH	PID feedback	R
	002DH	AI1	R
	002EH	AI2	R
	002FH	High pulse input	R
	0030H	Terminal status	R
	0031H	PLC current steps	R
	0032H	length reference	R
0033H	Actual length	R	
0034H	External count	R	
Runging/Stop Mornitor parameters	0035H	X1 termial status 0: Invalid 1: Valid	R
	0036H	X2 termial status 0: Invalid 1: Valid	R
	0037H	X3 termial status 0: Invalid 1: Valid	R
	0038H	X4 termial status 0: Invalid 1: Valid	R
	0039H	X5 termial status 0: Invalid 1: Valid	R
	003AH	X6 termial status 0: Invalid 1: Valid	R
	003BH	X7 termial status 0: Invalid 1: Valid	R
	003CH	X8 termial status 0: Invalid 1: Valid	R
	003DH	Reserved	R

4. CRC16 Function

```

unsigned int  CRC16 (unsigned char *data, unsigned char length)
{
    int i, crc_result=0xffff;

```

```
while (length--)  
{  
    crc_result^=*data++;  
    for (i=0; i<8; i++)  
    {  
        if (crc_result&0x01)  
            crc_result= (crc_result>>1) ^0xa001;  
        else  
            crc_result=crc_result>>1;  
    }  
}  
  
return (crc_result= ((crc_result&0xff) <<8) | (crc_result>>8));  
}
```