



# Frequency Inverter

(200V-1140V)

SHENZHEN WINNER S&T CO., LTD.







---

## Trademark Definition

1. "W", the initial of WINNER, signifies the current sine waveform. It simply and vividly expresses the trade the company is in. The beautiful and flowing W consists of 2 Vs indicating the inverter's operating principle of inverting current from one sine wave to another. In addition, it signifies the vitality of the company, and arouses the enthusiasm of its staff to build the company's international reputation and enhance product competitiveness, as well as to promote its enterprise ideology of harmony, endeavor, honesty, win-win
2. The perfect combination of the soaraway W and the red ellipse indicate that the company has been persisting on incessant innovation, seeking for greater perfection in quality. It also means the company is doomed to stand out in the inverter industry through all the staff's hardwork.
3. The trademark is concise, modern and integrated, which well represents the company's image, distinctive brand characteristics and unique brand conception.
4. The trademark matches well with the company's conception "Technology saves energy, wisdom creates future".
5. The color mainly adopts red and dark blue. Red signifies fervency, solemnness and splendor. Dark blue represents broadness, profundity and steadiness.

# SHENZHEN WINNER S&T CO., LTD.

**Concile unit of China Electric Equipment Industrial Association, Inverter Branch**

**Shenzhen high and new technology enterprise**

Established in Mar., 2004, Shenzhen WINNER S&T Co., Ltd. is one of China's Top 10 inverter manufacturers. It is the first medium-voltage inverter manufacturer in Shenzhen, and it is also the council unit of China Electric Appliance Industrial Association, Inverter Branch.

By virtue of its powerful R&D department, WINNER developed all its software and hardware, and own independent intellectual property. With a production area up to 8000 square meters and anual production capacity of 100,000 units, WINNER has keeping the fastest developement pace.

WINNER has successively launched 17-series high end inverters with different control modes like, V/F control, Vector control; different operation modes, like 2-quadrant operation, 4-quadrant operation; different main cuicuit topology structure, like bi-level, tri-level, multi-level. Besides, Winne also specilizes in producing high end energy-saving derivatives ans systems.

WINNER is committed to increasing customer value through a sharp focus on product innovation and customer satisfaction. From the technology accumulated over the past 5 years, the unending challenging spirit, and from enthusiasm towards the customer, we say with confidence that WINNER is doomed to stand out in the inverter industry.



## WINNER's Milestone

- Mar. 2004, Shenzhen WINNER was established with its mission to develop and manufacture first class inverters and energy-saving equipments.
- June, 2004, Win-9G series of inverters was launched and obtained wide approbate from customers
- In 2005, Win-9GF and Win-9GV had been successfully developed and launched. Meanwhile, Medium voltage inverter project was started.
- Aug., 2006, WINNER passed UKAS."ISO9001"
- 2006, Win-9EV, Win-9L, Win-9U series inverters was developed successively, and the company fulfills the products' specialization and diversification.
- Dec.2006, WINNER's Hi-voltage products successfully passed the strict test executed by electric drive design institute of Tianjin, and WINNERS became the first company in Shenzhen, which owns self-developed medium & low voltage inverters and other energy-saving products.
- Mar., 2007, Honored with the tile of "Shenzhen high-new technology enterprise"
- June.,2007,awarded with the certificate of "owning independent intellectual property"
- July, 2007, the factory moved to building 3, Antongda industry zone, and the operation area was expanded to be 8000 square meters.
- Aug., 2007, becoming the first council member of inverter branch of china electric appliance industry association.
- Sep. 2007, WIN-VA, WIN-VB, WIN-VC full series of vector control inverters were successfully developed,
- In the latter half of 2007, 17 units of hi-voltage products successively began to serve in coal steam-electric plant, steel plant, chemistry plant, cement plant. And WINNER became the mains supplier of inverter.
- Dec. 2007, WINNER's developing strength and results are approbated by Shenzhen Science and Technology Bureau. And WINNER got rewards from the government.
- May, 2008, WINNER was titled with "one of the top 10 brands of hi-voltage inverter of 2007" by HC360.
- June, 2008, WINNER was elected as one of the top ten satisfactory brands in 2007 by ELECTRIC AGE.
- October,2008, One unit of inverter of 8000kW,10KV produced by WINNER started to service in the field of iron and steel. This inverter is the one with biggest capacity among all Chinese brands at that time.
- 2009, New generation of high performance frequency inverter, Win-V63, was launched with 5 national petents .

## WINNER Conception

### Enterprise Spirits

Harmony, Endeavor, Honesty, Win-win.

### Business Principle

To attract customers by credit, to win customers by quality, to serve customs by products.

### R&D Principle

Seeking increasing perfection and catching up the world's latest technology.

### Quality Principle

To improve quality by advanced management, to satisfy customers by aesthetic ideology.

### Service Principle

To feedback to the customers by high efficiency; To influence the customers by professional competence; To impress the customer by sincerity; To move the customer by satisfaction.

### Market Principle

To strictly execute the regulation of customer notification and registration, and protect the interest of our distributors and agents.

To periodically hold technical training activities for our distributors and agents.

To periodically hold partner talkfest, and establish sound and close cooperating relationship.

### Value Conception

To naturalize the earth, to save energy for motherland, to deepen the welfare for employees, to seek development opportunities for the enterprise.

5



Technology Saves Energy    Wisdom Creates Future

# Product Features

6



Full Range of Low-voltage Frequency Inverter

## WINNER Low-voltage Products List

Name Description	Model Prefix	Voltage	Power
Sensorless vector control inverter	WIN-V63	200V/400V	0.25~400kW
Closed-loop vector control inverter	WIN-VC	200V/400V /690V	1.5~1000kW
V/F control frequency inverter for general application	WIN-9G/P	400V	1.5~1000kW
V/F control frequency inverter for general application	WIN-9GV	1200/2300V	18~630kW
Escalator inverter	WIN-V6E	400V	5.5~37kW
Energy-feedback and four-quadrants inverter	WIN-9E	400V	18~75kW
Oil pumping unit energy-saving system	WIN-PSS-ER/EP	400V	18~75kW
Injection machine energy-saving system	WIN-PSS-IV	400V	7.5~75kW
General purpose energy-saving system	WIN-PSS-G	400V	1.5~1000kW
Pump & Fan energy-saving system	WIN-PSS-P	400V	18~1000kW
Name Description	Model Prefix	Voltage	Current
Energy-feedback braking unit.	WIN-9U-PFB	400V	40A/80A
Resistance energy-consumption braking unit	WIN-9U-RDB	400V/690V/1200V	25A/40A/70A/140A/280A

7

## Basic Features Of WINNER Low-voltage Products:

- ❑ Years-accumulated application know how enables WINNER capable of producing low-voltage inverter whose rated current is up to 1800A;
- ❑ Unique low inductance bus structure ensures nice stability of inverter;
- ❑ The distinctive ventilation, heat and dust-proof design enhances WINNER inverters' high reliability;
- ❑ Friendly user keypad facilitates convenient operation.
- ❑ WIN-PSS-IV series inverter dedicated for injection molding machine applications owns remarkable potential in energy-saving efficiency;
- ❑ WIN-PSS-C series inverter for air compressor applications, and WIN-PSS-P series inverter for pump and fan applications also dominate a large market share among all other Chinese inverter manufacturers due to their high performance and high reliability. They have become the first choices for high power air compressors, pump and fans. While Energy feedback and four-quadrant inverter system has been extensively used in the oil field extractors, submersible pumps, elevators and small mine hoist, etc.

## WIN-V63 Sensorless Vector Control Inverter

Rated Voltage: 200V-240V/ 380V-440V Rated Power: 0.25 ~ 400kW

### Main Features

- Power range: 0.25-2.2kW for single-phase 200V-240V; 0.4-400kW for 3-phase 380V-440V;
- Stationary/rotary motor parameter autotuning function ;
- Inbuilt PLC operation and process PI control;
- Inbuilt braking unit for 45kW or below models as standard. 90kW or above is equipped with external DC choke;
- Multi-step speed operation (up to 16-step speed);
- Wobble operation;
- Continuous operation function upon momentary power failure;
- Perfect fault protection and auto current limiting function;
- Positive/negative logic switch input signal;
- 42 functions for input terminals and 22 functions for output terminals;
- 10 master frequency reference sources and 10 auxiliary frequency reference sources for your choice;
- 2 terminals for high frequency signal input (max.50KHz), 1 terminal for high frequency signal output (max. 50KHz);
- Frequency reference sources and run command sources can be easily switched online, bringing more convenience for debugging and operation;
- Inbuilt RS-485 communication port (MODBUS protocol).



### Scope of Application:

- WIN-V63 Series inverters are general purpose ones. It is suitable for inertia load applications, potential load applications and other applications with high requirement on response time; It is also much applicable for pump and fan applications in power plants, iron & steel plants, mines, chemical plants, HVAC, as well as mechanical drive control applications in the fields of textile, manufacturing, paper-making, wire-drawing, printing, etc.

### Keypad Function



Key	Name	Color	Function
PRG	Program/exit	Gray	Enter or exit programming status
ENTER	Enter/confirm	Gray	Enter lower level menu or confirm data
>>	Shift	Gray	In modifying mode, pressing this key to select the bit to be modified. In other mode, this key is used to check different parameters, such as voltage, current, frequency, etc. by scrolling actions.
∨	Decrement	Gray	Decrease value or parameter
∧	Increment	Gray	Increase value or parameter
RUN	Run key	Green	Press this key to run the inverter in the mode of keypad control
STOP RESET	Stop/reset	Red	Press this key to stop or reset the inverter
JOG	Jog key	Gray	In keypad control mode, press this key to start jog operation.

## Technical Specification

Items	Specification
Input rated voltage & frequency	single phase , 200V ~ 240V , 50Hz/60Hz ; three phase , 380V ~ 440V , 50Hz/60Hz
Allowed fluctuation	voltage fluctuation: within $\pm 10\%$ ; voltage imbalance: $< 3\%$ ; frequency fluctuation: within 5%.
Output voltage	3 phase, 0 ~ 220V; 3 phase , 0 ~ 380V
Output frequency	0 ~ 400.0Hz
Overload capability	150% of rated current: 2 Min; 180% of rated current: 10s
Control mode	Sensorless vector control; V/F control.
Run command reference mode	By panel ; by terminals ; by PC via series port
Speed setting mode	Digital setting by panel ; analog setting ; by series port or other frequency setting mode
Speed setting precision	Digital setting : $\pm 0.01\%$ ( - 10°C ~ + 40°C ) ; analog setting : $\pm 0.05\%$ ( 25°C $\pm$ 10°C )
Speed setting resolution	Digital setting : 0.01Hz ; analog setting : 1/2000 of max. frequency
Speed control precision	Sensorless vector control: $\pm 0.5\%$ ; ( 25°C $\pm$ 10°C )
Speed control range	Sensorless vector control : 1 : 100
Torque control response	Sensorless vector control : $< 200\text{ms}$
Start torque	Sensorless vector control : 180% of rated torque/0.5Hz
Torque control precision	$\pm 5\%$
Reference voltage supply output	1 port , +10V/5mA
Control voltage supply output	24V/200mA ;
Analog input	2 ports , AI1 voltage 0 ~ 10V , AI2 voltage optional/ current 0 ~ 10V / 0 ~ 20mA DC ,
Analog meter output	2 ports , 0 ~ 10V/0 ~ 20mA DC , current/voltage optional
Run command input	2 ports , FWD : forward operation ; REV reverse operation
Programmable digital input	Totally 8 programmable digital signal input terminals (X1~X8). X7 and X8 can receive high speed pulse signal. Note: For 3.7kW and below models, there are totally 5 programmable digital signal input terminals (X1~X5), X4 and X5 can receive high speed pulse signal.
DO frequency signal output	1 port, high-frequency signal output(programmable)
Collector open-loop output	Two ports:Y1,Y2. Y2 can be selected as pulse output(3.7kW or below, only Y1 available)
Programmable relay output	1 port RA/RB/RC, contactor capacity: 250V AC/3A or 30V DC/1A
Serial communication port	RS-485 interface RS485+, RS485-
4-digit LED display	frequency reference, output frequency, output voltage, output current, motor speed, output torque, fault code, etc..
Indication lamp	Parameter unit, RUN/STOP status, special status, charging status.
Requirement on Ambient temperature	-10°C ~ +40°C , with fluctuation $< 0.5^\circ\text{C}/\text{Min}$ ; Deration above 40°C. The output current should be derated by 2% with the increase of per 1 °C. The allowed highest temperature is 50°C
Humidity	Less than 95% RH , No condensation
Vibration	Less than $5.9\text{m}/\text{S}^2$ (0.6g)
Storage temperature	-40°C ~ +70°C
Enclosure	IP20
Cooling mode	Forced air cooling(natural cooling for the inverter with 0.4kW or below)



## WIN-VC Closed-loop Vector Control Inverter

Rated Voltage: 200V-240V/380V-440V/660V-690V Rated Power: 0.75 ~ 1000kW

( ≥355kW 380V~440V and ≥185kW 660V~690V is V/F control )

### Main Features

- Suitable for the large inertia applications, potential load applications and applications with high requirement in accuracy, response time and torque;
- Four control mode for option: V/F control, V/F control with PG, sensorless vector control, vector control with PG;
- Massive advanced functionalities available: energy saving control, speed control, slip compensation, torque compensation, moment control, zero-servo control, motor parameter autotuning, parameter copy, etc;
- High starting torque at low speed: 150% 1Hz (0Hz in the mode of vector control with PG);
- Speed control range hits 1:1000; Speed control accuracy hits 0.02% (under vector control with PG);
- Output frequency accuracy: +/- 0.01%;
- Multi-function input/output terminals, multi-function analog input/output function and serial communication function make operation more convenient;
- Perfect parameter online monitoring function, fault diagnosis function, protection and alarm function guarantee reliability of the inverter;
- RS-485 Communication (MODBUS Protocol), RS-485 communication card is optional.

10

### Keypad Function



Key	Function
LOCAL/REMOTE	keypad control / terminal control switch
MENU	To select the menu items
ESC	Go back to the previous page
RESET	To select the bit of the parameter to be modified; To reset the inverter when a fault occurs.
DATA/ENTER	To define the mode, parameter and settings.
△	To select the parameter code or increase the setting values.
▽	To select the parameter code or decrease the setting values.
JOG	Press this key to enable jog operation in keypad control mode
FWD/REV	To switch the motor's rotating direction in keypad control mode
RUN	Press this key to start the inverter in the keypad control mode, meanwhile, the RUN indicator will turn on
STOP	Press this key to stop the inverter in the keypad control mode; meanwhile, the STOP indicator will turn on. While in the terminal control mode, this key is enabled or disabled by the setting of the parameter O2-02.

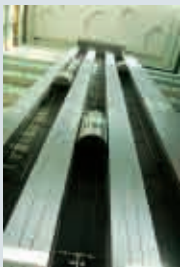

Circuit Diagram

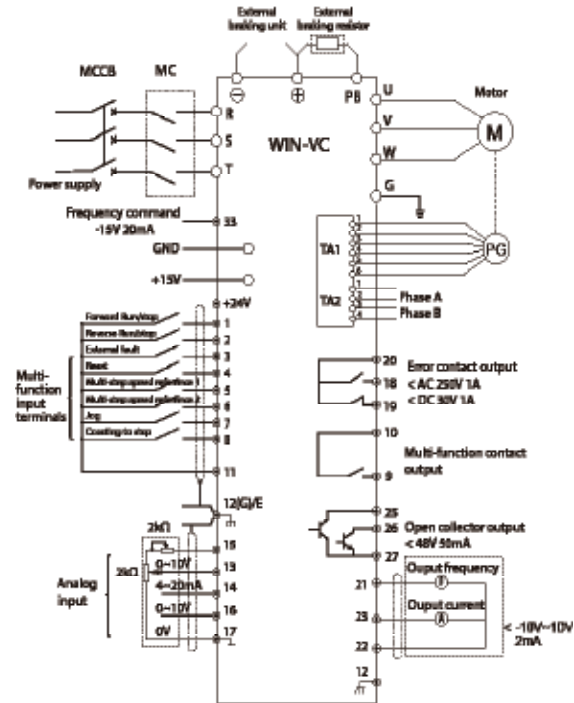

Item	Terminal	Signal function	Function description
Control signal	1	Forward / stop	Inverter runs forward when connected, stops when disconnected
	2	Reverse / stop	Inverter run reversely when connected, stops when disconnected
	3	External fault input	Input external fault when connected, and not when disconnected
	4	Fault reset	To reset fault when connected
	5	Master/ auxiliary speed switch	Anxilliary frequency command when connected
	6	Multi-step speed command 2	Effective while connected
	7	Jog command	Effective while connected
	8	Coast to stop	Effective while connected
	11	switching value input common terminal	
Analog input signal	15	speed command power supply +15V	Speed command setting power supply terminal +15V
	33	speed command power supply -15V	Speed command setting power supply terminal -15V
	13	Master frequency command	0 ~ 10V/100% frequency, -10 ~ +10V/-100% ~ +100% frequency
	14		4 ~ 20mA/100% frequency
	16	Auxilliary frequency command	0 ~ 10V/100% frequency, -10 ~ +10V/-100% ~ +100% frequency
	17	Common terminal	Common terminal of Terminal 13 & 14
12	Shielded earthing terminal	To connect the sheath of the shielding wire	
Digital output signal	9	Operating signal	To connect when operating
	10		
	25	Zero-speed output	To connect when the frequency is the lowest
	26	Speed arrival output	Frequency reference within +/-2Hz is low level.
	27	Common terminal of terminal 25&26	
18 ~ 20	Fault contact output	To fail while terminal 18 and 20 are connected; and terminal 19, 20 are disconnected	
Analog output signal	21	Frequency meter output	0~10V/100% frequency Multi-functon analog value monitoring1
	22	Analog input common terminal	
	23	Current meter output	0~5V/100% current Multi-functon analog value monitoring2
supplementary power supply	+15V	+15V	
	GND	+15V common terminal	Save level as ermental 17
	+24V	+24V	Common ground with terminal 1~8 the current is below 100mA

## WIN-9 (G, P, T, H) -T4 Standard Inverter

Rated Voltage: 380V-440V Rated Power: 1.5 ~ 1000kW

### Main Features

12

- This series inverter is applicable in the fields of oil, chemistry, plastic, paper making, foods, cement, printing and dyeing, metallurgy, water supply, HAVC, etc.;
- SPWM technology enables this series inverter with rated torque output at low speed, powerful load capacity;
- Inbuilt PID function, facilitating online parameter adjustment;
- Perfect protection function and fault diagnosis system greatly enhance the inverter's reliability and stability;
- 11~200kW models adopt the sealed dust-proof enclosure, prolonging the inverter's service life;
- Independent cooling air channel with low wind resistance, ensuring good cooling efficiency;
- Main circuit low induction design and optimized components layout enhance the inverter's load potential;
- Inbuilt Keypad as standard, with extension for option (Max. extension: 50m);
- Renesas 32-bit MCU, making the current waveform more close to the sine waveform. Less harmonics and low noise;
- Two-line LED Keyboard display: two different operating parameters can be displayed at the same time;
- 4 programmable output terminals (2 for programmable relay output, 2 for open-collector output);
- Standard operation mode (RUN/STOP), 2-wire operation mode (FOR or REV/STOP), and 3-wire operation mode for option;
- Manual voltage output expands scope of application;
- Upto 75kW models have inbuilt braking unit for option;
- RS-485 Communication(MODBUS Protocol), RS-485 communication card is optional.



### Keypad Function



Key	Function
PRG	To enter the menu of functions
SET	To store the values while setting the parameters. To modify the monitored contents in the lower LCD
ESC	To exit from the data modification of function items ; To modify the monitored contents in the upper LCD
△	To increase the function code or its content. To increase the function code of fault display...
▽	To decrease the function code or its content. To decrease the function code of fault display...
FOR	To start the inverter by issuing a command of forward rotating in the mode of keypad control.
STOP/ RESET	In the event of operation: to stop the machine according to the preset deceleration time. In the event of fault: to reset (reset is disabled while fault exists).
REV/ JOG	Press this key for reverse rotation in the condition that the machine is under keypad control, and the value of F014 is 1.

13

### Circuit Diagram

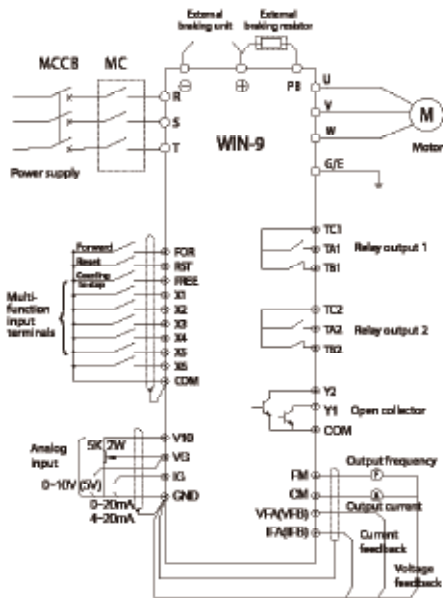

- Note:
- 1.The purpose to install MC is to avoid of restart at fault or restart when power is cut.
  - 2.The resistor' s overheat protection of external braking unit shall be connected to multi-function input terminal. (X1 ~ X6 )is set in constant 10' s terminal.
  - 3.○ the main-circuit terminal,⊙ control circuit terminal.

Category	Terminal code	Name	Function description
Control signal	COM	+24V common terminal	—
	FOR	Forward	Effective while connected to COM
	FREE	Free stop terminal	Effective while connected to COM
	RST	Reset terminal	Effective while connected to COM
	X1~X6	multi-function input terminal	Programmable multi-functional contact input
switch output signal	TA1, TB1, TC1	fault contact output1	to fail while terminal TA and TC are connected; and terminal TB and TC are disconnected.(programmable)
	TA2, TB2, TC2	fault contact output2	
	Y1, Y2	output signal	In the course of operation,open collector Open Collector signal output (programmable)
analog output signal	FM	frequency meter output	0~10V/100% frequency;multi-function analog value monitoring
	CM	Current meter output	0~5V/100% current;multi-function analog value monitoring
	V10	Signal power supply10V	Analog +10V power supply
	VG	Preset analog input voltage	0~10V / 100%, 0~5V/100%
	IG	Preset analog input current	4~20mA / 100%, 0~20mA/100%
	VFA, VFB	voltage feedback input signal	0~10V
	IFA, IFB	Current feedback input signal	4~20mA
	GND	common	—
supplementary power supply	+24V, COM	24Vsupplementary power supply	+24V

## WIN-9GV-T11 Powerful High Performance Inverter

Rated Voltage: 1200V/2300V Rated Power: 75 ~ 630kW

### Main Feature

- The inverting circuit adopts neutral point vicing 3-level PWM structure;
- Simple circuit structure enhances the inverter's reliability. It can realize higher voltage output without serial connection of power components;
- Less harmonics: output voltage waveform is close to sine waveform;
- Small dv/dt, no special requirement on the motor's insulate performance;
- Compact.

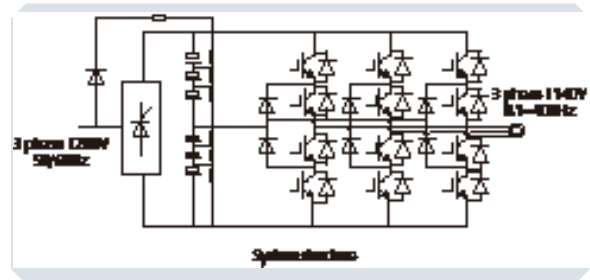

14

### Performance Features

- Suitable for the high-end heavy inertia load applications, potential load applications and applications with high requirement on accuracy and response;
- For control modes for option: V/F control, V/F with PG;
- Energy-saving function makes the motor working in the best condition. Auto operation can be realized with PID regulator;
- Slip compensation greatly stabilizes the motor;
- Inbuilt auto torque compensation function;
- Auto reset function;
- Friendly LCD keypad;
- Online parameters modification and copy;

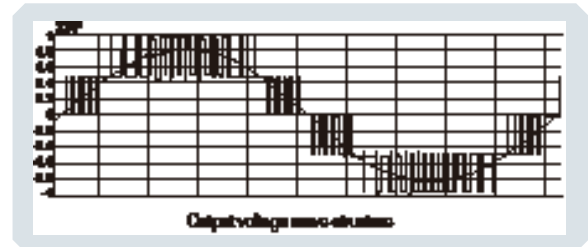

## Keypad And Functions



Key	Function
LOCAL/REMOTE	Control by keyboard/control by control terminal
MENU	Options for 5 modes.
ESC	Go back to the previous page
RESET	To select the displace of values while setting the parameters To reset the fault in the event of failure
DATA/ENTER	To define the mode, parameter and settings.
▲	To select the parameter code or increase the setting values.
▼	To select the parameter code or decrease the setting values.
JOG	Press this key for inching operation while the command is given by keyboard.
FWD/REV	To switch the motor's rotating direction in the condition of keyboard operation.
RUN	Press this key to start the inverter in the conditional of keyboard operation, meanwhile, the light of run will turn on
STOP	Press this key to stop the inverter in the conditional of keyboard operation; meanwhile, the light of stop will turn on. In the condition of terminal control operation, to enable or disable the function of this key by choosing the parameter O2-02

15

## Circuit Diagram

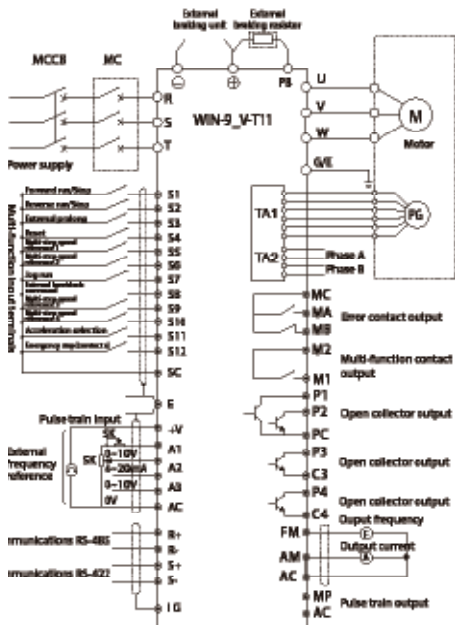

category	terminal code	name	function description
control signal	S1	Forward / stop	to run forward while connected, to stop while disconnected
	S2	Reverse / stop	to run reversely while connected, to stop while disconnected
	S3	Multi-function input option 1	to fail while connected
	S4	Multi-function input option 2	to reset while connected
	S5	Multi-function input option 3	multi-step speed command 1 is effective while connected
	S6	Multi-function input option 4	multi-step speed command 2 is effective while connected
	S7	Multi-function input option 5	jog option while connected
	S8	Multi-function input option 6	To block the external reference frequency while connected
	S9	Multi-function input option 7	External speed command 3 is effective while connected
	S10	Multi-function input option 8	External speed command 4 is effective while connected.
	S11	Multi-function input option 9	Acceleration, deceleration time option 1 while connected
	S12	Multi-function input option 10	Abnormal stop while connected.
	SC	Common terminal of switch input	--
analog input signal	+V / -V	speed command power supply+15V/-15V	speed command setting power supply terminal, +15V/-15V
	A1	main speed frequency command	0~10V/100%; -10~+10V/-100%~+100%
	A2	multi-function analog input	0~10V/100%; -10~+10V/-100%~+100%; 4-20mA/100%
	A3	multi-function analog input	0~10V/100%
	AC	common terminal	0V
photocoupler output	E (G)	shielding wire groundingterminal	to connect the shielding sheath of shielding wire
	P1	Multi-function PHC output	Zero speed
	P2	Multi-function PHC output 2	frequency output
	PC	common terminal	P1,P2common terminal
relay output	P3 / C3	Multi-function PHC output 3	To close when operating preparation is ready
	P4 / C4	Multi-function PHC output 4	frequency checkout 2
	MA	fault point output	to fail while the terminal MA and MC are connected
	MB		
analog output signal	MC	multi-function contact output	The terminal M1 and M2 will be connected in the course of operation.
	M1 / M2		
	FM		
pulse input	AC	analog input common terminal	
	AM	current meter output	0~5V/100% current
RS-485/422	RP	multi-function pulse input	frequency command input
	MP	multi-function pulse monitoring	output frequency
	R+	MEMOBUS communication input	RS-485/422 2-wire drive R+,S+,R-,S-
	R-		
S+			
S-	MEMOBUS communication output		
IG	communication shielding wire	--	

## WIN-V6E Escalator Frequency Inverter

Rated Voltage: 380V-440V    Rated Power: 5.5 ~ 37kW

### Product features

- This inverter can meet all the demands of escalator control without using extra PLC and other control board;
- The inverters are equipped with inbuilt braking unit as standard;
- Phase-sequence detection function allows protection on fault phase or phase loss;
- Unique mains supply/inverter switching solution ensure smoothness. The impact current created by WIN-V6E is only 1-3 times of the motor's rated current, compared averaged 10 times. People on the escalator cannot feel shock during the process;
- Automatic/manual energy-saving function;
- Strong overload capability: 150% - 2 Min;
- MODBUS and CAN bus communication;
- Perfect escalator control logic(maintenance operation, reverse enter protection, star/delta start, roller shutter related function, earthquake related function, fire disaster related function, over speed protection, under-speed protection, security controller control, oiling control, handrail detection, security circuit detection);
- Synchronous motor control/asynchronous motor control;
- Stationary/rotary motor parameters autotuning;
- Carrier frequency - 16K, enabling super-silent operation;
- Inbuilt PG card port;
- Inbuilt 4-digit LED keypad;
- Meet the standards of IEC61800-3 /EN115.

### Scope of Application

- WIN-V6E inverter is dedicated for escalators.



## WIN-9E Energy Feedback 4-Quadrants Frequency Inverter

Rated Voltage : 380V-440V Single-unit power : 18~75kW

### Main Feature

- This Series of products have been extensively used for electrical towage in the field of oil and mining;
- Adopting the inverting technology and phase-locking control of IGBT,it returns the excessive energy on the DC bus from the motor to the power grid so that to achive 4-quadrants operation of the driven motor;
- The regenerative energy is returned to the power gird though filter without pollution. Compared to the nomral energy-consumption braking, the efficiency is 10% higher;
- The inside adopts non-contactor switch, protection level reaches IP50 or above. It is suitable to be used in harsh enviroment with its strong resistance to humidity and corrosion;
- This product has perfect function of protection and diagnoses. Personalized design,more parameters to be displayed and simple operation enable the user to operate more conveniently and safely.

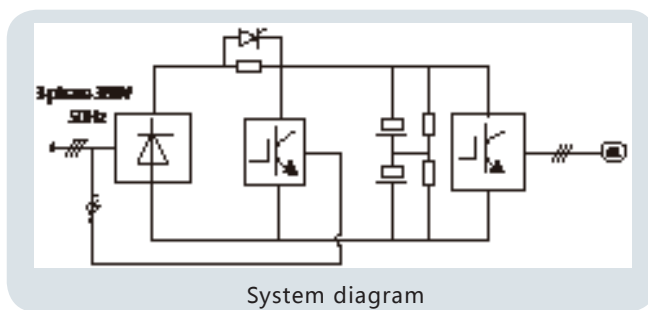

## WIN-PSS-ER/EP Energy-Saving System For Oil pumping unit

Rated Voltage: 380V-440V

Rated Power: 18 ~ 75kW

- WIN-PSS-ER/EP is oil pumping unit energy saving system. WIN-PSS-EP shares the same software with WIN-9E, while WIN-PSS-ER shares the same software with WIN-9G-T4B;
- WIN-PSS-ER Series inverter can realize stepless speed control to the main motor of oil pumping units. Users can adjust freely the oil pumping unit's stroke frequency, up/down travel speed. Compared with traditional mechanically stroke adjustment, WIN-PSS-ER can achieve the oil pumping unit's efficiency and accordingly increase the oil pumping unit's output;
- This series inverter has inbuilt bypass system, allowing the motor to be switched freely between inverter and mains supply.

18

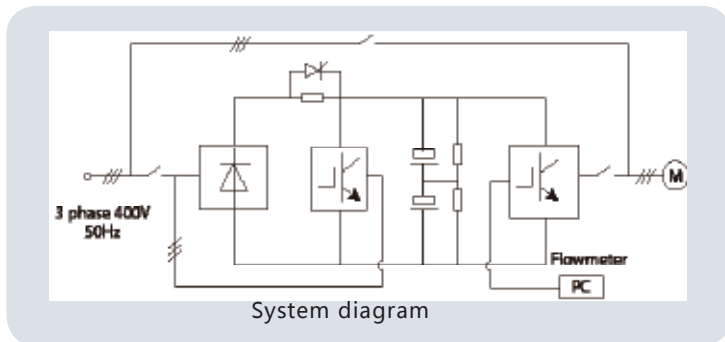

## WIN-PSS-IV Energy-Saving System For Injection Machine

Rated Voltage: 380V-440V Rated Power: 7.5 ~ 75kW

In practical production, over power margin is common and results in energy waste. The production process include mold clamping, mold locking, plastic injecting, pressure maintaining, plastic heating, cooling, mould sinking, etc. Needed power pressure and flow rate of each process varies. Especially for the light load, energy waste is more.

For plastic injecting machine of fixed capacity, the power source, pump motor, operates with constant speed to offer constant flow quantity. The excessive liquid pressure flows back through overflow valve. Simultaneously, long-term feedback flow will cause the violent friction between liquid pressure oil and components, which results in heating of oil and affect components' durance.

This unit drives the oil pump motor according to the signal from the pressure-flow proportional value on the injection machine. It saves a lot of power energy with no compromise of fulfilling all the function of the system what' s more it overcomes all the above shortcomings. It is the imperative and ideal driving solution for the injection machine with dosing pump. Normally, energy-saving rate is above 20 percent.

Advantages after use inverter to drive

- High energy saving rate: Save 30%~65% energy;
- Soft start of motor: Small impact to power network reduces the power transforming equipment capacity in application, reduce noise and improve working environment;
- Improve power factor: Reduce wattless power consumption;
- High reliability: Release vibration and components wearing, reduce oil heat, prolong the lifespan of equipment and mould Single Machine feature;
- Vertical cross section is the same as wall hanging, take small space;
- Function of main power switched circuit, keep production continue when accident;
- Simple operating, flexible and convenient.



19

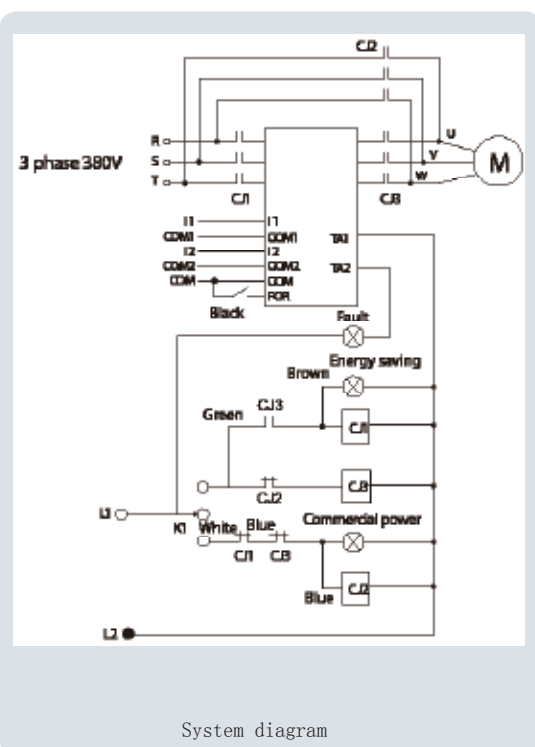

## WIN-PSS-G Energy-saving System

Rated Voltage: 380V-440V    Rated Power: 18 ~ 1000kW

- WIN-PSS-G is designed for the speed-adjustable equipments with energy-saving potential. It is much suitable for applications with varying torque such as conveyor belts and ball grinding mills.
- This series inverter has been widely used in the fields of oil, mines, chemical, remotion, food, etc. We can also produce custerized moldes upon your requirments.
- This series inverter has inbuilt bypass system, allowing the motor to be switched freely between inverter and mains supply.



20

## WIN-PSS-P Energy-saving System for Pump and Fan

Rated Voltage: 380V-440V    Rated Power: 1.5 ~ 1000kW

- WIN-PSS-P is a kind of energy-saving system designed for pump and fan applications. On the basis of changing the motor' s power supply frequency and PID regulating theory, this series inverter has amazing energy saving potential.
- This series inverter has been widely used in the fields of oil, mines, chemical, remotion, food, etc. We can also produce custerized moldes upon your requirments.
- This series inverter has inbuilt bypass system, allowing the motor to be switched freely between inverter and mains supply.



### WIN-9U-PFB Energy Feedback Unit

Rated Voltage: 380V-440V Rated current: 40A, 80A

#### Main Features:

- The feedback unit is actually a three-phase inverting device, which can feed back redundant energy in the DC bus to the grid, efficient and environment-friendly. It is suitable for DC bus system, and attach to a inverter.
- The unit can help reduce production cost on condition that the motor is powered by the DC bus system.
- The unit can help realize 4-quadrant operation through attachment to a universal inverter.

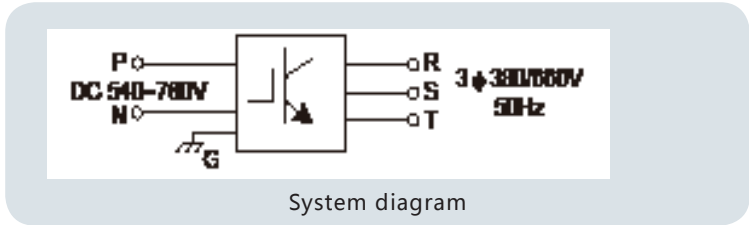

### WIN-9U-RBD Braking Unit With Energy-Consumption Resistor

Rated AC Voltage:400V	Rated current:25A,40A,70A,140A,280A
690V	40A,70A,140A,280A
1200V	40A,70A,140A

#### Main Features:

- This braking unit realizes energy consumption through connecting to an external resistor, so the efficiency is not satisfying.
- This unit is commonly used in the 4-quadrant operation situation for simple structure and low cost.

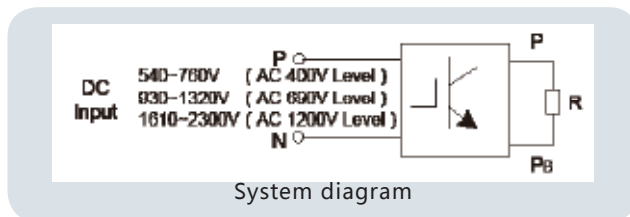

External Dimension & Mounting Dimension:

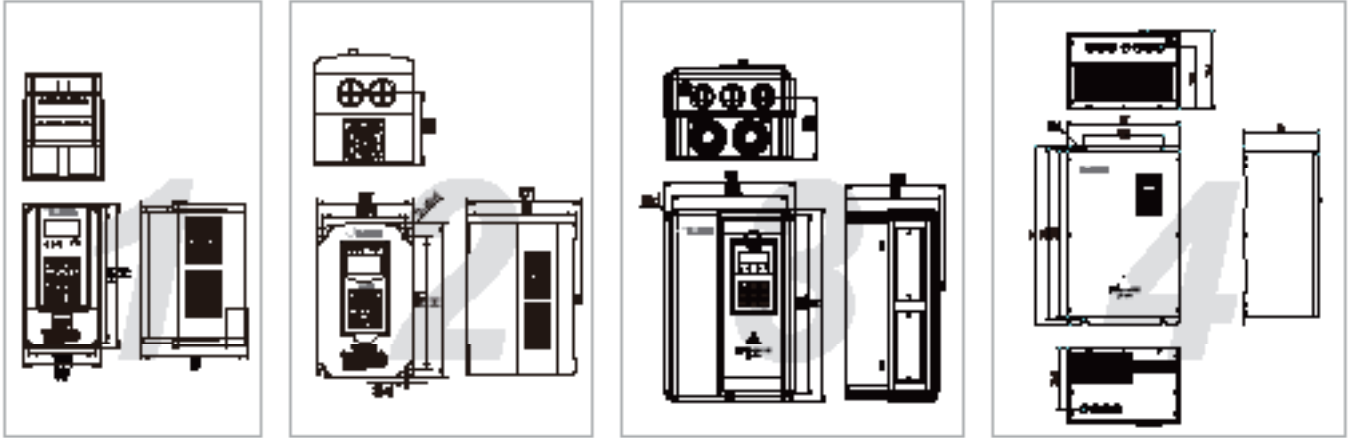

22

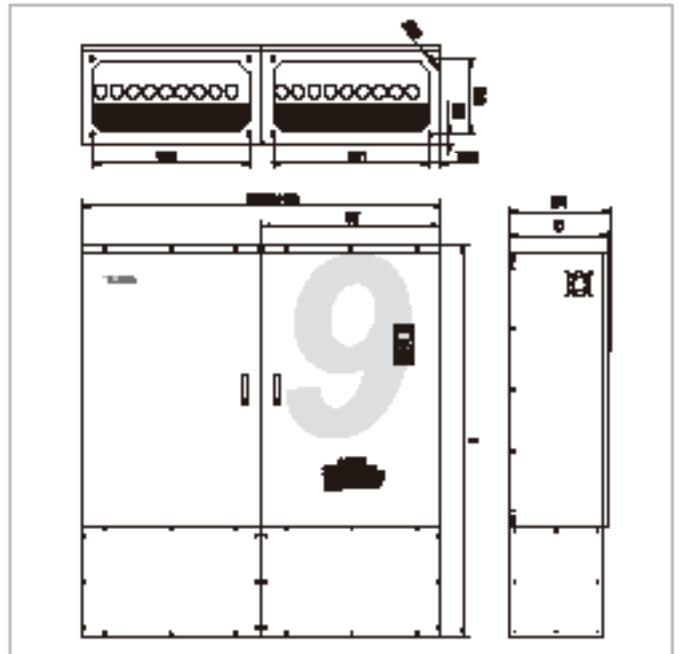
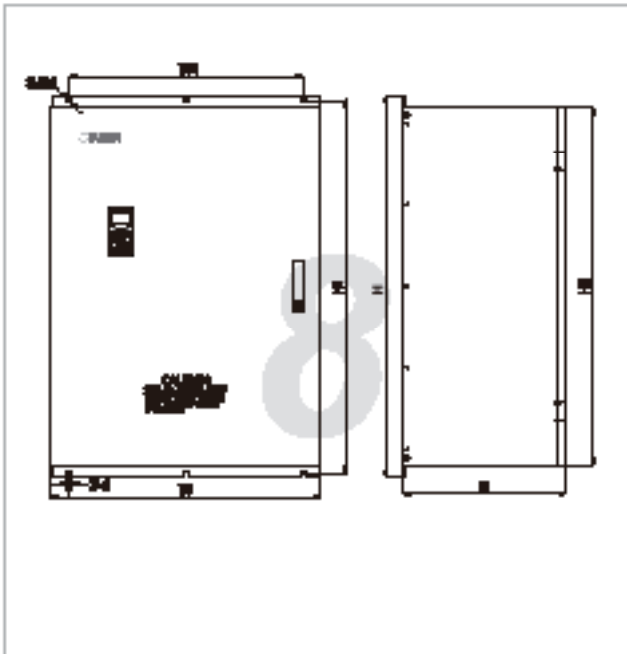
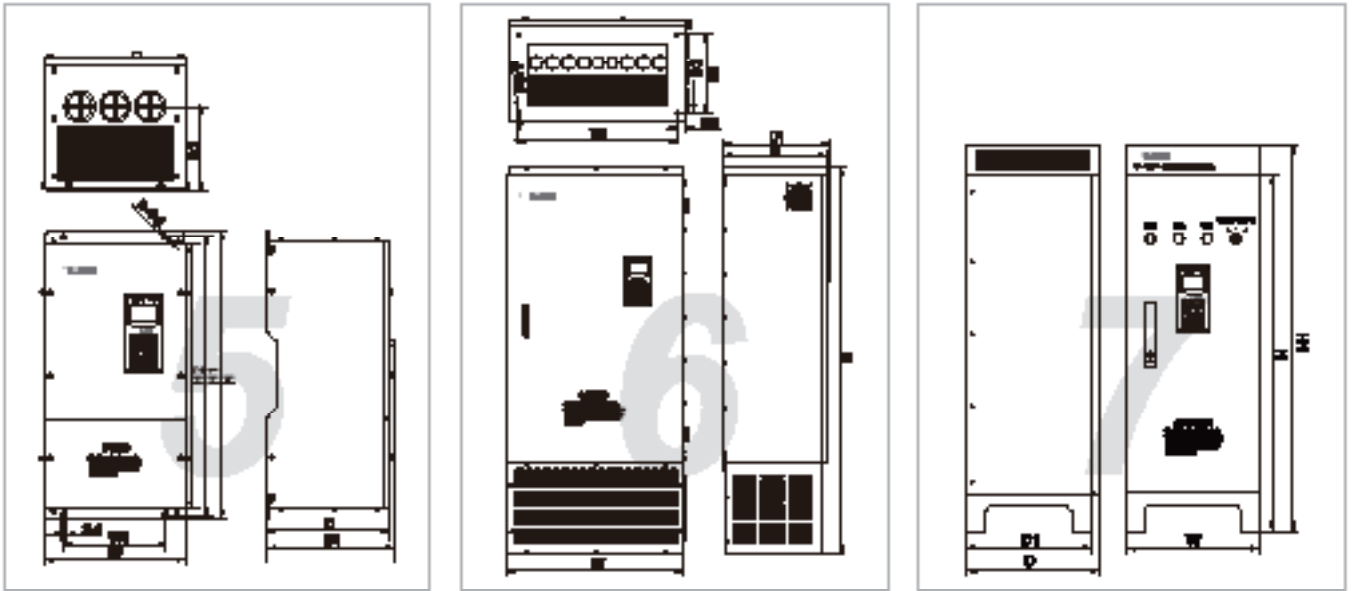

Model No.: WIN-V63/WIN-V6E Voltage: 400V Wall-mounted type												Model No.: WIN-9GV Voltage: 1200V Cabinet type																
Power	W	W1	H	H1	H2	D	D1	D2	D3	d	F	Power	W	H	D	F	-	-	-	-								
0.4~1.5	105	95	185	174	-	139	147.6	81.4	-	5	3	75 ~ 132	750	1400	450	6	-	-	-	-								
2.2~3.7	115	105	220	209	-	154	162.5	81.4	-	5	3	160 ~ 245	750	1600	450	6	-	-	-	-								
5.5~7.5	215	190	320	295	-	155	163	103	-	7	3	280 ~ 400	1000	2000	450	6	-	-	-	-								
11~15	250	225	320	295	-	175	183	123	-	7	3	500 ~ 630	1500	2000	500	6	-	-	-	-								
18~22	310	200	500	485	465	230	240	170	-	7.5	5	Model No.:WIN-9GV Voltage: 1200V Wall-mounted type																
30~45	355	240	600	580	553	250	260.5	184	-	10	5	Power	W	W1	H	H1	H2	D	d	F								
55~75	430	300	680	655	629	290	300.5	233.5	232	12	4	30~55	600	500	970	940	900	400	11	8								
90~110	475	350	754	729	703	290	300.5	233.5	232	12	4	75~132	750	650	1070	1040	1000	450	13	8								
132~160	530	350	880	850	819	330	340.5	256	276	14	4	160~245	750	650	1270	1240	1200	450	13	8								
200~250	680	500	1000	975	940	350	360.5	258.5	270	14	4	280~400	1000	900	1670	1640	1600	450	13	8								
Model No.: WIN-V63 Voltage: 200V Wall-mounted type												Model No.:9U-PFB Voltage:400V Wall-mounted type																
Power	W	W1	H	H1	H2	D	D1	D2	D3	d	F	Power	W	W1	H	H1	D	d	-									
0.2~0.4	96	86	160	149	-	114.5	123.1	56	-	5	3	40A	254	200	456	440	185	7	4	-								
0.7~1.5	105	95	185	174	-	139	147.6	81.4	-	5	3	80A	360	240	600	580	185	7	4	-								
2.2	115	105	220	209	-	154	162.5	81.4	-	5	3	Model No.:9U-RDB Voltage:400/690/1200V Wall-mounted type																
Model No.: WIN-V63 Voltage: 400V Cabinet type												Power	W	W1	H	H1	D	F	-	-								
Power	W	W1	H	H1	H2	D	D1	D2	D3	d	F	400V-40A	142	100	234	220	120	4	-	-								
132~160	530	420	1110	-	-	330	340.5	250	-	18	6	400V-70A	190	140	270	250	225	4	-	-								
200~250	680	600	1230	-	-	350	360.5	270	-	18	6	690V-70A																
Model No.: WIN-V_ / WIN-9_ Voltage: 400V Wall-mounted type												690V-40A	220	140	340	320	225	4	-	-								
Power	W	W1	H	H1	H2	D	D1	D2	D3	d	F	1200V-40A																
VC1.5~7.5	190	170	290	260	—	217	225	105	-	5.5	2	1200V-70A									220	140	400	385	250	4	-	-
1.5~3.7	150	130	231	205	—	167	175	109	-	5.5	2	1200V-140A																
5.5~7.5	190	170	290	260	—	187	195	105	-	5.5	2	400V-140A									250	180	460	440	280	4	-	-
011~015 and 9P-018	245	200	410	390	367	240	245	170	-	7	5	400V-280A																
018~030	278	200	550	530	490	250	260	155	-	10	5	690V-140A																
9P-037	348	200	550	530	490	250	260	185	-	10	5	690V-280A																
037~045 and 9P-055	348	240	700	680	640	335	345	215	-	10	5	Model No.: WIN-PSS Voltage:400V Cabinte type																
055~075	375	300	785	760	717	335	345	240	-	12	5	Power	Model	W	H	D	F	-	-	-								
093~132 and 9P-160	530	420	920	890	852	335	345	250	-	12	5	18~75	ER/EP	800	1600	600	7	-	-	-								
160~200	695	580	1140	1110	1072	335	345	250	-	14	5	7.5~15	IV/P/G	300	700	250	7	-	-	-								
220~400	820	600	1334	1300	1260	450	460	250	-	14	5	18~30		280	808	280	7	-	-	-								
Model No.: WIN-V_ / WIN-9_ Voltage:400V Cabinet type												37~45		350	978	340	7	-	-	-								
Power	W	W1	W2	H	D	D1	D2	D3	d	F	-	55~75		377	1060	340	7	-	-	-								
160~200	695	620	40	1800	450	460	40	345	18	6	-	93~132		1020	1800	450	6	-	-	-								
220~400	820	690	40	1800	450	460	40	345	18	6	-	160~200		1320	1800	450	6	-	-	-								
500	1100	950	75	2200	450	460	40	345	18	6	-	220~400		1640	1800	450	6	-	-	-								
560~800	820	720	40	2000	450	460	40	345	18	9	-	Keypad																
1000	1100	950	75	2200	450	460	40	345	18	9	-	Model	W	W1	H	H1	D	D1	-	-								
Model No.: WIN-VC Voltage: 690V Wall-mounted type												WIN-V63 power ≤3.7	50	39	75	60.5	16	31.7	-	-								
Power	W	W1	H	H1	H2	D	D1	D2	d	F	-	WIN-V63	70	46	115	108	17	32.3	-	-								
037~110	400	300	750	725	690	400	410	250	12	5	-	WIN-9_ WIN-V_	70	66	138	134	20	30	-	-								
132~220	605	480	1200	1160	1117	450	460	240	14	5	-	WIN-9GV	70	57	120	111	16	22	-	-								
245~315	874	720	1180	1140	1097	450	460	265	14	5	-	Model No.: WIN-VC Voltage: 690V Cabinet type																
Model No.: WIN-VC Voltage: 690V Cabinet type												Power	W	W1	W2	H	D	D1	D2	D3	d	F	-					
Power	W	W1	W2	H	D	D1	D2	D3	d	F	-	355~500	1100	950	75	2000	450	460	41.5	350	18	6	-					
355~500	1100	950	75	2000	450	460	41.5	350	18	6	-	560~630	874	750	62.5	1800	450	460	41.5	350	18	9	-					
560~630	874	750	62.5	1800	450	460	41.5	350	18	9	-	710~1000	1100	950	75	2000	450	460	41.5	350	18	9	-					
710~1000	1100	950	75	2000	450	460	41.5	350	18	9	-																	

### Strong R&D team

WINNER houses a 50-people professional R&D team, with the staff of brave fulfillment, continuous innovation and high quality. 35% of them have got master degree or doctor degree. By virtue of their wisdom and diligence, they are always dedicated in cultivating high-tech products, and meanwhile combine the production well with the market demands to introduce newer and better products.



24

### Well-equipped Laboratories

WINNER has made huge investment in building 3 laboratories, developing and debugging laboratory, EMC test laboratory, environment test laboratory. All of WINNER products are developed and tested strictly according to CE standard.



### Strict production and quality control

WINNER quality control system conforms with ISO9001:2000. WINNER products are manufactured according to GB/T12668.2-2002, GB12668.3-2003, GB/T12668.4-2006 and GB3859.1-1993.



## Guarantee

1. Warranty Period: 18 months as per the shipment date
2. Within warranty period, WINNER has two service solutions optional for the customers.
  - Solution 1:
    - In case that the inverter breaks down, the buyer needs to provide the fault details and clear photos of the damaged inverter and its series number to the seller.
    - If the breakdown of the inverter is caused by quality problem, the seller shall provide free of charge corresponding spare parts for the buyer's repair work. The parts shall be shipped along with the next order. In case the buyer needs delivery by express, the buyer and the seller should both bear half of the express freight.
  - Solution 2:
    - The seller provides a price list of wearing parts to the buyer. The buyer buys spare parts standby.
    - In case that the inverter breaks down, the buyer can do repair work in advance and meanwhile provide detailed information on this damaged one. If the inverter is damaged for quality problem, the seller shall deduct the cost of the replaced parts from the next order.
3. When the products is out of warranty period, WINNER shall always offers paid service.
4. WINNER offers technical training on the site of its factory.

25

## □ Honors and certificates



**SHENZHEN WINNER S&T CO., LTD.**

Address: Building 3, Antongda Industrial Park, Liuxian 3rd  
Road, Baoan District, Shenzhen, China

Web: [www.WINNERS.net.cn](http://www.WINNERS.net.cn) E-mail: [sales@WINNERS.net](mailto:sales@WINNERS.net)

