



FRENIC 5000G11S/P11S

High-Performance, Low-Noise Inverter

General-Purpose Industrial Machines

230V Series

0.25HP/FRNF25G11S-2UX
to 125HP/FRN125G11S-2UX

460V Series

0.50HP/FRNF50G11S-4UX
to 600HP/FRN600G11S-4UX

Fans and Pumps

230V Series

7.5HP/FRN007P11S-2UX
to 150HP/FRN150P11S-2UX

460V Series

7.5HP/FRN007P11S-4UX
to 800HP/FRN800P11S-4UX



CAUTION

- Read all operating instructions before installing, connecting (wiring), operating, servicing, or inspecting the inverter.
- Ensure that this instruction manual is made available to the final user of the inverter.
- Store this manual in a safe, convenient location.
- The product is subject to change without prior notice.



Preface

Thank you for purchasing our FRENIC5000G11S or FRENIC5000P11S series inverter. This product is used to drive a 3-phase electric motor at variable speed. As incorrect use of this product may result in personal injury and/or property damage, read all operating instructions before using. As this manual does not cover the use of option cards, etc., refer to relevant manuals for option operations.

Safety Instructions

Read this manual carefully before installing, connecting (wiring), operating, servicing, or inspecting the inverter. Familiarize yourself with all safety features before using the inverter.

In this manual, safety messages are classified as follows:

 WARNING	Improper operation may result in serious personal injury or death.
 CAUTION	Improper operation may result in slight to medium personal injury or property damage.

Situations more serious than those covered by CAUTION will depend on prevailing circumstances. Always follow instructions.

Instructions on use

WARNING

- This inverter is designed to drive a 3-phase induction motor and is not suitable for a single-phase motor or others, **as fire may result.**
- This inverter may not be used (as is) as a component of a life-support system or other medical device directly affecting the personal welfare of the user.
- This inverter is manufactured under strict quality control standards. However, safety equipment must be installed if the failure of this device may result in personal injury and/or property damage.
There is a risk of accident.

Instructions on installation

WARNING

- Mount this inverter on an incombustible material such as metal.
There is a risk of fire.
- Do not place combustible or flammable material near this inverter, **as fire may result.**

CAUTION

- Do not hold or carry this inverter by the surface cover. Inverter may be dropped **causing injury.**
- Ensure that the inverter and heat sink surfaces are kept free of foreign matter (lint, paper dust, small chips of wood or metal, and dust), **as fire or accident may result.**
- Do not install or operate a damaged inverter or an inverter with missing parts, **as injury may result.**

Instructions on wiring

WARNING

- Connect the inverter to power via a line-protection molded-case circuit breaker or Fuse, **as fire may result.**
- Always connect a ground wire, **as electric shock or fire may result.**
- A licensed specialist must perform the wiring works, **as electric shock may result.**
- Turn off the power before starting the wiring work, **as electric shock may result.**
- Wire the inverter after installation is complete, **as electric shock or injury may occur.**

CAUTION

- Confirm that the phases and rated voltage of this product match those of the AC power supply, **as injury may result.**
- Do not connect the AC power supply to the output terminals (U,V,and W), **as injury may result.**
- Do not connect a braking resistor directly to the DC terminals (P(+)and N(-)), **as fire may result.**
- Ensure that the noise generated by the inverter, motor, or wiring does not adversely affect peripheral sensors and equipment, **as accident may result.**

Instructions on operation

WARNING

- Be sure to install the surface cover before turning on the power (closed). Do not remove the cover while power to the inverter is turned on.
Electric shock may occur.
- Do not operate switches with wet hands, **as electric shock may result.**
- When the retry function is selected, the inverter may restart automatically after tripping.
(Design the machine to ensure personal safety in the event of restart)
Accident may result.
- When the torque limiting function is selected, operating conditions may differ from preset conditions (acceleration/deceleration time or speed). In this case, personal safety must be assured.
Accident may result.
- As the STOP key is effective only when a function setting has been established, install an emergency switch independently, and when an operation via the external signal terminal is selected, the STOP key on the keypad panel will be disabled.
Accident may result.
- As operations start suddenly if alarm is reset with a running signal input, confirm that no running signal is input before resetting alarm.
Accident may result.
- Do not touch inverter terminals when energized even if inverter has stopped.
Electric shock may result.

CAUTION

- Do not start or stop the inverter using the main circuit power.
Failure may result.
- Do not touch the heat sink or braking resistor because they become very hot.
Burns may result.
- As the inverter can set high speed operation easily, carefully check the performance of motor or machine before changing speed settings.
Injury may result.
- Do not use the inverter braking function for mechanical holding.
Injury may result.

Instructions on maintenance, inspection, and replacement

WARNING

- Wait a minimum of five minutes (30HP or less) or ten minutes (40HP or more) after power has been turned off (open) before starting inspection. (Also confirm that the charge lamp is off and that DC voltage between terminals P (+) and N (-) do not exceed 25V.)
Electrical shock may result.
- Only authorized personnel should perform maintenance, inspection, and replacement operations. (Take off metal jewelry such as watches and rings. Use insulated tools.)
Electric shock or injury may result.

Instructions on disposal

CAUTION

- Treat as industrial waste when disposing it.
Injury may result.



Other instructions

WARNING

- Never modify the product.
Electric shock or injury may result.

Conformity to Low Voltage Directive in Europe

CAUTION

- The contact capacity of alarm output for any fault (30A, B, C) and relay signal output (Y5A, Y5C) is 0.5A at 48V DC.
- The ground terminal  G should be connected to the ground.
Use a crimp terminal to connect a cable to the main circuit terminal or inverter ground terminal.
- Where RCD (Residual-current protective device) is used for protection in case of direct or indirect contact, only **RCD of type B** is allowed on the supply side of this EE (Electric equipment).
Otherwise another protective measure shall be applied such as separation of the EE from the environment by double or reinforced insulation or isolation of EE and supply system by the transformer.
- Use a single cable to connect the  G inverter ground terminal. (Do not use two or more inverter ground terminals.)
- Use a molded-case circuit breaker (MCCB) and magnetic contactor (MC) that conform to EN or IEC standards.
- Use the inverter under over-voltage category III conditions and maintain Pollution degree 2 or better as specified in IEC664. To maintain Pollution degree 2 or more, install the inverter in the control panel (IP54 or higher level) having structure free from water, oil, carbon, dust, etc.
- For the input-output wiring of the inverter, use cable (diameter and type) as specified in Appendix C in EN60204.
- To ensure safety, install an optional AC reactor, DC reactor, or external braking resistor as follows:
 - 1) Install inside an IP4X cabinet or barrier if electrical parts are exposed.
 - 2) Install inside an IP2X cabinet or barrier if electrical parts are not exposed.
- It is necessary to install the inverter in appropriate method using an appropriate RFI filter to conform to the EMC directive. It is customer's responsibility to check whether the equipment, the inverter is installed in, conforms to EMC directive.

Conformity to Low Voltage Directive in Europe



Table 1-1 Applicable equipment and wire size for main circuit in Europe

Voltage	Application motor [HP]	Inverter type	Fuse/MCCB current rating [A]		Tightening torque [N*m]				Recommended wire size [mm ²]							
			With DCR	Without DCR	L1/R, L2/S, L3/T U, V, W	P1, P(+), DB, N (-)	G	R0, T0	Control	L1/R, L2/S, L3/T (G)		U, V, W	R0, T0	P1, P(+)	P(+), DB, N (-)	Control
										With DCR	Without DCR					
3phase 230V system	1/4	FRNF25G11S-2UX	5	5	1.2					2.5 (2.5)	2.5	-	2.5			
	1/2	FRNF50G11S-2UX	5	5												
	1	FRN001G11S-2UX	5	10												
	2	FRN002G11S-2UX	10	15	1.8					2.5 (2.5)	2.5	-	2.5			
	3	FRN003G11S-2UX	10	15												
	5	FRN005G11S-2UX	20	30												
	7.5	FRN007P11S-2UX	30	40	3.5					6(6)	10(10)	4	2.5	4	2.5	
	7.5	FRN007G11S-2UX														
	10	FRN010P11S-2UX	40	60												
	10	FRN010G11S-2UX			5.8					10 (10)	16 (16)	6	2.5	6	10	
	15	FRN015P11S-2UX	50	100												
	15	FRN015G11S-2UX														
	20	FRN020P11S-2UX	75	125	13.5					25 (16)	50 (25)	16	2.5	16	3.5	
	20	FRN020G11S-2UX														
	25	FRN025P11S-2UX	100	150												
	25	FRN025G11S-2UX			1.2					35 (16)	35	25	0.7	25	5.5	
	30	FRN030P11S-2UX	100	175												
	30	FRN030G11S-2UX														
	40	FRN040P11S-2UX	150	200	27	13.5				50 (25)	25 × 2 (25)	50	2.5	16 × 2	4	
	40	FRN040G11S-2UX														
	50	FRN050P11S-2UX	175	250												
	50	FRN050G11S-2UX			48	27				70(35)	35 × 2 (50)	70	2.5	25 × 2	6	
	60	FRN060P11S-2UX	200	300												
	60	FRN060G11S-2UX														
	75	FRN075P11S-2UX	250	350	27	13.5				95 (50)	50 × 2 (50)	25 × 2	2.5	35 × 2	6	
	75	FRN075G11S-2UX														
	100	FRN100P11S-2UX	350	-												
	100	FRN100G11S-2UX			48	27				35 × 2 (35)	70 × 2 (70)	35 × 2	2.5	50 × 2	10	
100	FRN100P11S-2UX	350	-													
125	FRN125P11S-2UX	400	-													
125	FRN125G11S-2UX			48	27				50 × 2	-	50 × 2	2.5	70 × 2	16		
125	FRN125G11S-2UX															
150	FRN150P11S-2UX	500	-													

Note: The type of wire is 75°C (167°F) 600V Grade heat-resistant polyvinyl chloride insulated wires (PVC).

The above-mentioned wire size are the recommended size under the condition of the ambient temperature 50°C (122°F) or lower.

Conformity to Low Voltage Directive in Europe



Table 1-2 Applicable equipment and wire size for main circuit in Europe

Voltage	Application motor [HP]	Inverter type	Fuse/MCCB current rating [A]		Tightening torque [N*m]			Recommended wire size [mm ²]							
			With DCR	Without DCR	L1/R, L2/S, L3/T U, V, W P1, P (+), DB, N (-)	G	R0, T0	Control	L1/R, L2/S, L3/T (G)		U, V, W	R0, T0	P1, P (+)	P (+), DB, N (-)	Control
									With DCR	Without DCR					
3phase 460V system	1/2	FRNF50G11S-4UX	5	5	1.2			-	0.7	2.5 (2.5)	2.5	-	2.5	2.5	2.5
	1	FRN001G11S-4UX	5	5	1.2			-							
	2	FRN002G11S-4UX	5	10	1.8			-							
	3	FRN003G11S-4UX	10	15	1.8			-							
	5	FRN005G11S-4UX	10	15	3.5			-							
	7.5	FRN007P11S-4UX	15	20	3.5			-							
	7.5	FRN007G11S-4UX	15	20	3.5			-							
	10	FRN010P11S-4UX	20	30	3.5			-							
	10	FRN010G11S-4UX	20	30	3.5			-							
	15	FRN015P11S-4UX	30	40	5.8			-							
	15	FRN015G11S-4UX	30	40	5.8			-							
	20	FRN020P11S-4UX	40	50	5.8			-							
	20	FRN020G11S-4UX	40	50	5.8			-							
	25	FRN025P11S-4UX	40	60	5.8			-							
	25	FRN025G11S-4UX	40	60	5.8			-							
	30	FRN030P11S-4UX	50	75	5.8			-							
	30	FRN030G11S-4UX	50	75	5.8			-							
	40	FRN040P11S-4UX	75	100	13.5			-							
	40	FRN040G11S-4UX	75	100	13.5			-							
	50	FRN050P11S-4UX	100	125	13.5			-							
	50	FRN050G11S-4UX	100	125	13.5			-							
	60	FRN060P11S-4UX	100	150	13.5			-							
	60	FRN060G11S-4UX	100	150	13.5			-							
	75	FRN075P11S-4UX	125	175	13.5			-							
	75	FRN075G11S-4UX	125	175	13.5			-							
	100	FRN100P11S-4UX	175	-	13.5			-							
	100	FRN100G11S-4UX	175	-	13.5			-							
	125	FRN125P11S-4UX	200	-	27			13.5							
	125	FRN125G11S-4UX	200	-	27			13.5							
	150	FRN150P11S-4UX	225	-	27			-							
	150	FRN150G11S-4UX	225	-	27			-							
	200	FRN200P11S-4UX	300	-	27			-							
	200	FRN200G11S-4UX	300	-	27			-							
	250	FRN250P11S-4UX	350	-	27			-							
	250	FRN250G11S-4UX	350	-	27			-							
	300	FRN300P11S-4UX	400	-	27			-							
	300	FRN300G11S-4UX	400	-	27			-							
	350	FRN350P11S-4UX	500	-	27			-							
	350	FRN350G11S-4UX	500	-	27			-							
	400	FRN400P11S-4UX	600	-	27			-							
400	FRN400G11S-4UX	600	-	27			-								
450	FRN450P11S-4UX	700	-	27			-								
450	FRN450G11S-4UX	700	-	27			-								
500	FRN500P11S-4UX	800	-	27			-								
500	FRN500G11S-4UX	800	-	27			-								
600	FRN600P11S-4UX	1,000	-	27			-								
600	FRN600G11S-4UX	1,000	-	27			-								
700	FRN700P11S-4UX	1,000	-	27			-								
800	FRN800P11S-4UX	1,200	-	27			-								

Note: The type of wire is 75°C (167°F) 600V Grade heat-resistant polyvinyl chloride insulated wires (PVC).

The above-mentioned wire size are the recommended size under the condition of the ambient temperature 50°C (122°F) or lower.

Compliance with UL/cUL standards [Applicable to products with UL/cUL mark]



Tightening torque and wire range

Voltage	Inverter type	Required torque [lb-inch](N·m)			Wire range [AWG] (mm ²)									
	G11S/P11S	Main terminal	Auxiliary control-power	Control	L1/R,L2/S,L3/T U,V,W	Auxiliary control-power	Control							
3-phase 230V	FRNF25G11S-2UX	10.6(1.2)	—	6.2(0.7)	16 (1.3)	—	24 (0.2)							
	FRNF50G11S-2UX													
	FRN001G11S-2UX													
	FRN002G11S-2UX	15.9(1.8)			10.6(1.2)			6.2(0.7)	14 (2.1)					
	FRN003G11S-2UX								10 (5.3)					
	FRN005G11S-2UX								8 (8.4)					
	FRN007G11S-2UX	31.0(3.5)			10.6(1.2)			6.2(0.7)	6 (13.3)					
	FRN007,010P11S-2UX								4 (21.2)					
	FRN010G11S-2UX								3 (26.7)					
	FRN015P11S-2UX	51.3(5.8)			10.6(1.2)			6.2(0.7)	2 (33.6)					
	FRN015G11S-2UX								1 (42.4)					
	FRN020P11S-2UX								2X2 (33.6X2)					
	FRN020G11S-2UX	119(13.5)			10.6(1.2)			6.2(0.7)	1X2(42.4X2)					
	FRN025P11S-2UX								2/0X2(67.4X2)					
	FRN025G11S-2UX								3/0X2(85X2)					
	FRN030P11S-2UX	239(27)			10.6(1.2)			6.2(0.7)	4/0X2(107.2X2)					
	FRN030G11S-2UX								250X2(127X2)					
	FRN040G11S/P11S-2UX								350X2(177X2)					
	FRN050P11S-2UX	425(48)			10.6(1.2)			6.2(0.7)	16 (1.3)	16(1.3)	24 (0.2)			
	FRN050G11S-2UX													
FRN060G11S/P11S-2UX														
FRN075G11S/P11S-2UX														
FRN100P11S-2UX														
FRN100G11S-2UX														
FRN125G11S/P11S-2UX														
FRN150P11S-2UX														
3-phase 460V	FRNF50G11S-4UX	10.6(1.2)	—	6.2(0.7)	16 (1.3)	—	24 (0.2)							
	FRN001G11S-4UX													
	FRN002G11S-4UX													
	FRN003G11S-4UX	15.9(1.8)			10.6(1.2)			6.2(0.7)	14 (2.1)					
	FRN005G11S-4UX											12 (3.3)		
	FRN007G11S-4UX												10 (5.3)	
	FRN007,010P11S-4UX	31.0(3.5)							10.6(1.2)					6.2(0.7)
	FRN010G11S-4UX											6 (13.3)		
	FRN015P11S-4UX												4 (21.2)	
	FRN015G11S-4UX	2 (33.6)												
	FRN020P11S-4UX								119(13.5)			10.6(1.2)		6.2(0.7)
	FRN020G11S-4UX												3X2 (26.7X2)	
	FRN025P11S-4UX	2X2 (33.6X2)												
	FRN025G11S-4UX								239(27)	10.6(1.2)	6.2(0.7)	2X2 (33.6X2)		
	FRN030P11S-4UX												4/0(107.2)	
	FRN030G11S-4UX	1X2(42.4X2)												
	FRN040G11S/P11S-4UX								425(48)	10.6(1.2)	6.2(0.7)	2/0X2(67.4X2)		
	FRN050G11S/P11S-4UX												3/0X2(85X2)	
	FRN060G11S/P11S-4UX	4/0X2(107.2X2)												
	FRN075G11S/P11S-4UX								300X2(152X2)					
FRN100P11S-4UX	350X2(177X2)													
FRN100G11S-4UX		500X2(253X2)												
FRN125G11S/P11S-4UX			425(48)	10.6(1.2)		6.2(0.7)	300X3(152X3)							
FRN150G11S/P11S-4UX	400X3(203X3)													
FRN200P11S-4UX		500X3(253X3)												
FRN200G11S-4UX			600X3(304X3)											
FRN250G11S/P11S-4UX														
FRN300P11S-4UX														
FRN300G11S-4UX														
FRN350G11S/P11S-4UX														
FRN400G11S/P11S-4UX														
FRN450P11S-4UX														
FRN450G11S-4UX														
FRN500G11S/P11S-4UX														
FRN600G11S/P11S-4UX														
FRN700P11S-4UX														
FRN800P11S-4UX														

Use the following power supply to the inverter

Inverter Model	Maximum input voltage	Input source current
FRNF25G11S-2UX ~ FRN125G11S-2UX FRN007P11S-2UX ~ FRN150P11S-2UX	AC240V	Not more than 100,000A
FRNF50G11S-4UX ~ FRN600G11S-4UX FRN007P11S-4UX ~ FRN800P11S-4UX	AC480V	

Compliance with UL/cUL standards [Applicable to products with UL/cUL mark]

CAUTION

- [CAUTION] Hazard of electrical shock. Disconnect incoming power before working on this control.
- [CAUTION] Dangerous voltage exists until charge lights is off.
- [WARNING]
- More than one live parts inside the inverter.
- Type1 "INDOOR USE ONLY"
The inverter is approved as a part used inside a panel. Install it inside a panel.
- Suitable for use on a circuit capable of delivering not more than 100,000rms symmetrical amperes.
- Use 60/75C copper wire only.
- A Class2 circuit wired with class1 wire.
- Field wiring connection must be made by a UL Listed and CSA Certified closed-loop terminal connector sized for the wire gauge involved. Connector must be fixed using the crimp tool specified by the connector manufacturer.
- Connect the power supply to main power supply terminals via the Molded-case circuit breaker (MCCB) or a ground fault circuit interrupter (GFCI) to apply the UL Listing Mark.
(See Instruction Manual basic connection diagram Fig.2-3-1).
- In case of using auxiliary control-power input (R0, T0), connect it referring to Basic connection diagram Fig.2-3-1.
- Solid state motor overload protection is provided in each model.

General instructions

Although figures in this manual may show the inverter with covers and safety screens removed for explanation purposes, do not operate the device until all such covers and screens have been replaced.

Contents

1. Before Using This Product	1-1	5. Function Select	5-1
1-1 Receiving Inspections	1-1	5-1 Function select list	5-1
1-2 Appearance	1-1	5-2 Function Explanation	5-7
1-3 Handling the Product	1-2	6. Protective Operation	6-1
1-4 Carrying	1-3	6-1 List of Protective Operations	6-1
1-5 Storage	1-3	6-2 Alarm Reset	6-2
2. Installation and Connection	2-1	7. Trouble shooting	7-1
2-1 Operating Environment	2-1	7-1 Protective function activation	7-1
2-2 Installation Method	2-1	7-2 Abnormal motor rotation	7-5
2-3 Connection	2-3	8. Maintenance and Inspection	8-1
2-3-1 Basic connection	2-3	8-1 Daily Inspection	8-1
2-3-2 Connecting the main circuit and ground terminals	2-8	8-2 Periodical Inspection	8-1
2-3-3 Connecting the control terminals	2-13	8-3 Measurement of Main Circuit Electrical Quantity	8-4
2-3-4 Terminal arrangement	2-16	8-4 Insulation Test	8-5
2-3-5 Applicable equipment and wire size for main circuit	2-18	8-5 Parts Replacement	8-5
3. Operation	3-1	8-6 Inquiries about Products and Product Guarantee	8-5
3-1 Inspection and Preparation before Operation	3-1	9. Specifications	9-1
3-2 Operation Method	3-1	9-1 Standard Specifications	9-1
3-3 Trial Run	3-1	9-2 Common Specifications	9-3
4. Keypad Panel	4-1	9-3 Outline Dimensions	9-4
4-1 Appearance of Keypad Panel	4-1	9-4 RS-485 Modbus RTU Serial Communications	9-8
4-2 Keypad Panel Operation System (LCD screen, Level Structure)	4-2	9-4-1 Transmission Specification	9-8
4-2-1 Normal operation	4-2	9-4-2 Connection	9-8
4-2-2 Alarm occurrence	4-2	9-4-3 Serial Interface Configuration	9-8
4-3 Operating Keypad Panel	4-4	9-4-4 Modbus RTU Functions	9-8
4-3-1 Operation Mode	4-4	9-4-5 Inverter Function Code Access	9-9
4-3-2 Setting digital frequency	4-4	9-4-6 Command and Monitor Data Registers	9-9
4-3-3 Switching the LED monitor	4-5	9-4-7 Data Format Specification	9-11
4-3-4 Menu screen	4-5	9-4-8 Communication Errors	9-15
4-3-5 Setting function data	4-5	10. Options	10-1
4-3-6 Checking function data	4-7	10-1 Built-in Options	10-1
4-3-7 Monitoring operating status	4-7	10-2 Separately Installed Options	10-2
4-3-8 I/O check	4-8	11. Electromagnetic compatibility (EMC)	11-1
4-3-9 Maintenance information	4-9	11-1 General	11-1
4-3-10 Load rate measurement	4-10	11-2 Recommended Installation Instructions	11-2
4-3-11 Alarm information	4-11	11-3 The harmonics restriction in Europe Union (EU)	11-5
4-3-12 Alarm history and factors	4-12		
4-3-13 Data copy	4-13		
4-3-14 Alarm mode	4-15		



1. Before Using This Product

1-1 Receiving Inspections

Unpack and check the product as explained below.

If you have any questions about the product, contact the nearest Fuji sales office or your local distributor where you purchased the unit.

- ① Check the ratings nameplate to confirm that the delivered product is the ordered one.

		
TYPE	FRN030G11S-4UX	
SOURCE	3PH 380-480V 50/60Hz 50A	
OUTPUT	3PH 30HP 380-460V 0.1-400Hz 45A 150% 1min	
SER.No.	75A123A0001Z	SCCR 100kA 720
Fuji Electric FA		Made in Japan

Ratings nameplate

TYPE : Inverter type

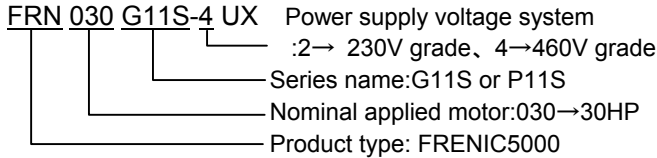

SOURCE : Power rating

OUTPUT : Output rating

MASS : Mass (not indicated for products with 30HP or less)

SER.No. : Serial number

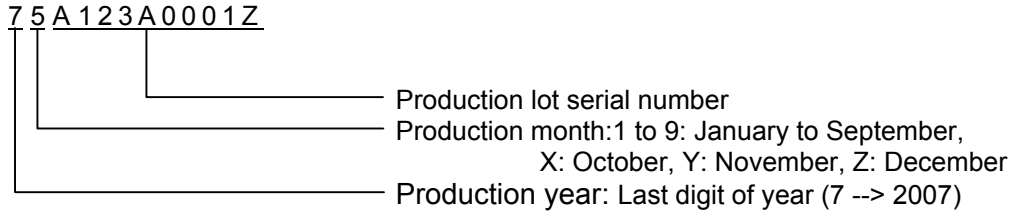

- ② Check for damaged and/or missing parts upon delivery.
- ③ In addition to the inverter unit and this manual, the package contains rubber bushing (for products with 30HP or less) and a terminating resistor (1/2 W, 120Ω). The terminating resistors for products with 30HP or less is packed in a sack. The terminating resistors for products with 40HP or more is connected to the control terminal of the inverter unit. This terminating resistor is required for RS-485 communication. The terminating resistor need not be removed regardless of RS-485 communication status.

1-2 Appearance

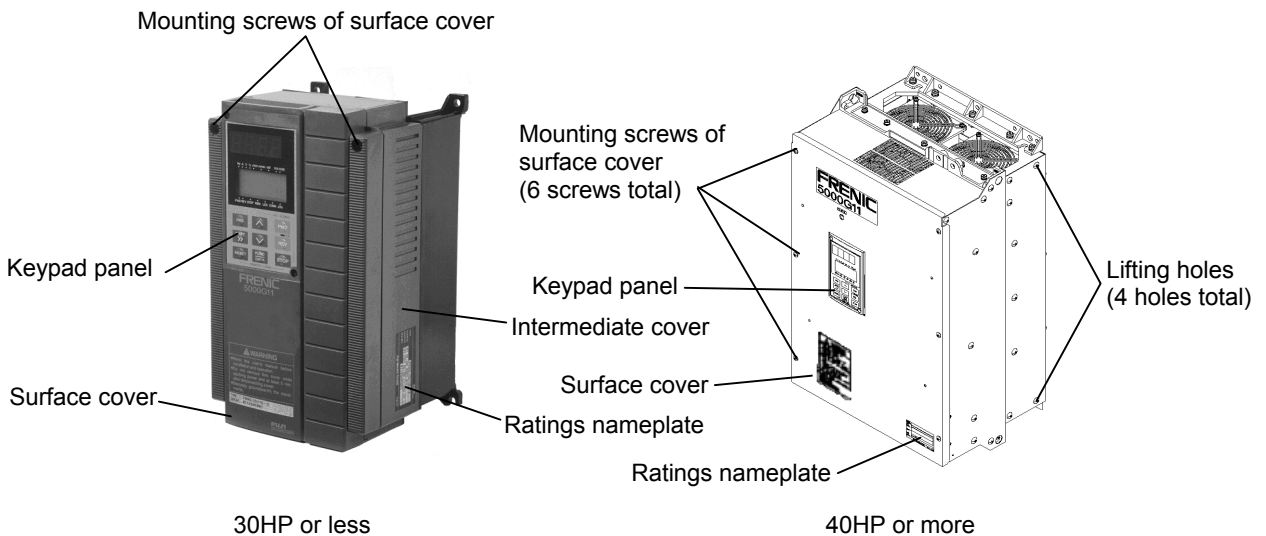

1-3 Handling the Product

(1) Removing the surface cover

For the inverter of 30HP or less, loosen the mounting screws of the surface cover, then remove the cover by pulling the top (see Figure 1.3.1).

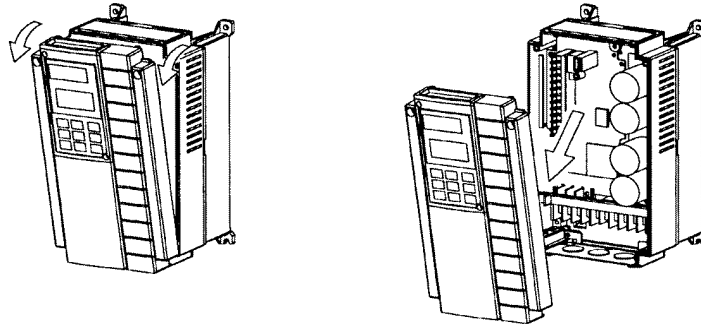

Fig. 1-3-1 Removing the surface cover (for inverter of 30HP or less)

For the inverter of 40HP or more, remove the six mounting screws of the surface cover, then remove the surface cover.

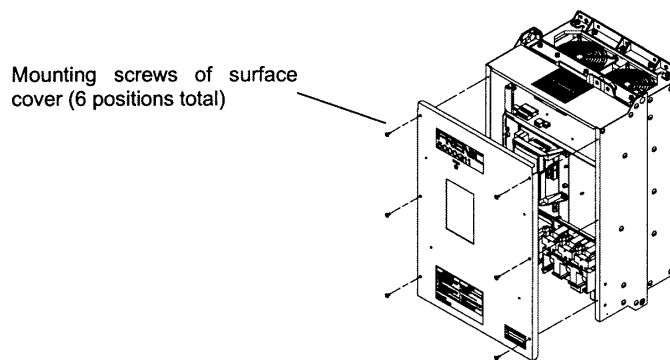

Fig. 1-3-2 Removing the surface cover (for inverter of 40HP or more)

(2) Removing the keypad panel

After removing the surface cover as explained in (1), loosen the mounting screws of the keypad panel and remove as shown in Figure 1.3.3.

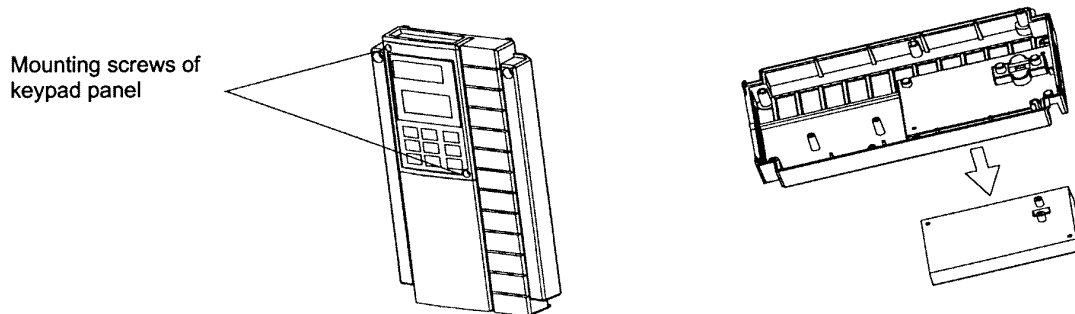

Fig. 1-3-3 Removing the keypad panel

Loosen the mounting screws of the keypad panel and remove using the finger holds on the keypad panel case.

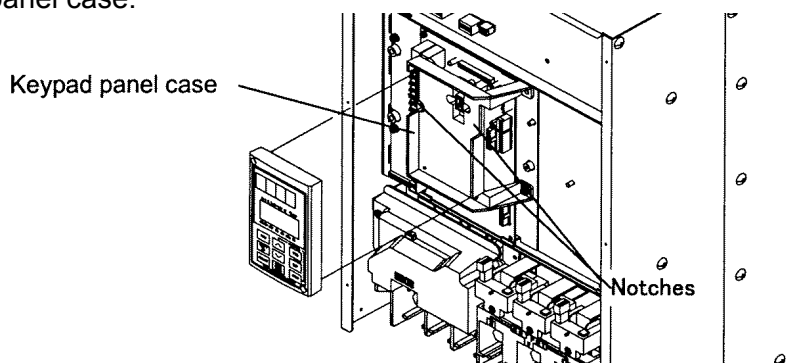

Fig. 1-3-4 Removing the keypad panel (for inverter of 40HP or more)

1-4 Carrying

Carry the product by the main unit.

Do not carry the product while holding the cover or parts other than the main unit.

Use a crane or hoist to carry a product equipped with hanging holes.

1-5 Storage

Temporary storage

Temporary storage of this product must meet those conditions listed in Table 1-5-1.

Table 1-5-1 Storage environment

Item	Specifications
Ambient temperature	-10°C(14°F) to +50°C(122°F)
Storage temperature	-25°C(-13°F) to +65°C(149°F)
Relative humidity	5 to 95% ^{Note2}
Atmosphere	Pollution degree 2
Air pressure	Operation/storage: 86 to 106 kPa Transport : 70 to 106 kPa

Note1: The storage temperature applies only to short periods such as transport.

Note2: As a large change in temperature within this humidity range may result in condensation or freezing, do not store where such temperature changes may occur.

- ① Do not place this product directly on a floor.
- ② To store the product in an extreme environment, pack in vinyl sheet, etc.
- ③ If the product is stored in a high-humidity environment, insert a drying agent (e.g., silica gel) and pack the product in vinyl sheet.

Long-term storage

If the product is to be stored for an extended period after purchase, the method of storage depends primarily on storage location.

The general long-term storage method is as follows:

- ① The above conditions for temporary storage must be satisfied.
When the storage period exceeds three months, the upper limit of ambient temperature must be reduced to 30°C(86°F) to prevent the deterioration of the electrolytic capacitors.
- ② Pack the product thoroughly to eliminate exposure to moisture and include a drying agent to ensure a relative humidity of about 70% or less.
- ③ If the product is mounted on a unit or control panel and is left unused and exposed to the elements like moisture or dust (particularly on a construction site), remove the product and store in a suitable environment.
- ④ Electrolytic capacitors not provided with power for an extended period will deteriorate. Do not store electrolytic capacitors for one year or longer without providing power.

2. Installation and Connection

2-1 Operating Environment

Install this product in a location that meets those conditions listed in Table 2-1-1

Table 2-1-1 Operating environment

Item	Specifications
Location	Indoor
Ambient temperature	-10°C(14°F) to +50°C(122°F)(For products of 30HP or less, the ventilating covers must be removed if ambient temperature exceeds +40°C(104°F))
Relative humidity	5 to 95% (No condensation)
Atmosphere	Pollution degree 2
Air pressure	86 to 106 kPa
Vibration	3mm:from 2 to less than 9 Hz, 1m/s ² :from 9 to less than 20 Hz, 1m/s ² :from 20 to less than 55 Hz, 1m/s ² :from 55 to less than 200 Hz

Table 2-1-2 Output current reduction rate based on altitude

Altitude	Output current reduction rate
3300ft (1000m) or lower	1.00
3300-4950ft (1000 to 1500m)	0.97
4950-6600ft (1500 to 2000m)	0.95
6600-8250ft (2000 to 2500m)	0.91
8250-9900ft (2500 to 3000m)	0.88

2-2 Installation Method

- Securely fasten the product in an upright position on a solid structure such that FRENIC5000G11S is facing the front. Do not turn the product upside down or install in a horizontal position.
- As heat is generated during inverter operation, the spaces shown in Fig. 2-2-1 are required to ensure sufficient cooling. As heat radiates upward, do not install the product beneath a device sensitive to heat.
- As the heat sink may reach a temperature of 90°C(194°F) during inverter operation, ensure that the material surrounding the product can withstand this temperature.

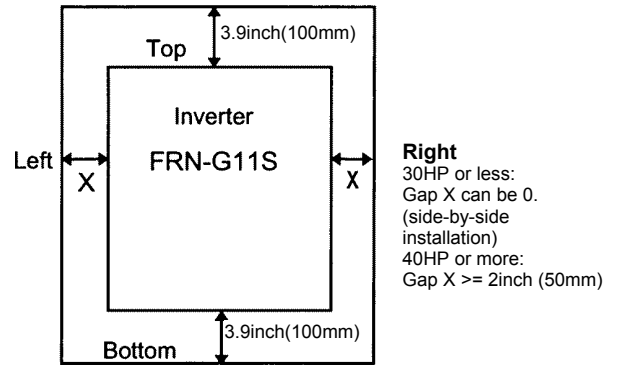

Fig.2-2-1

	WARNING Install this product on nonflammable material such as metal.
--	---

- When installing this product in a control panel, consider ventilation to prevent ambient temperature of the inverter from exceeding the specified value. Do not install the product in an area from which heat cannot be sufficiently released.
- If two or more inverters must be installed in the same device or control panel, arrange the units horizontally to minimize the effect of heat. If two or more inverters must be installed vertically, place an insulated plate between the inverters to minimize the effect of heat.
- When shipped from the factory, inverters are internal cooling type inside panel. An inverter of 30HP or less can be converted to an external cooling type simply by adding an optional mounting adapter. An inverter of 40HP or more can be converted simply by moving mounting adapter.

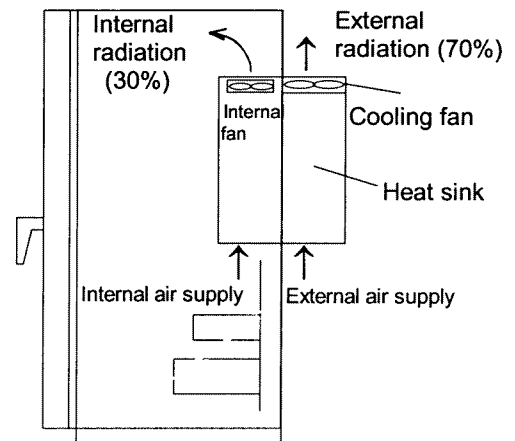

Fig.2-2-2

In an external cooling system, a heat sink radiating about 70% of total inverter heat (total loss) can be placed outside the device or control panel. Ensure that heat sink surfaces are kept free of foreign matter (lint, Fig. 2-2-2 External cooling system moist dust particles etc.).

	WARNING <ul style="list-style-type: none"> · In case of external cooling system, cover the inverter rear side in order not to touch the main capacitor and braking resistor. Electric shock may result. · Ensure that the inverter and heat sink surfaces are kept free of foreign matter such as lint, paper dust, small chips of wood or metal, and dust. Fire or accident may result.
--	---

An inverter of 40HP or more can be converted to an external cooling type simply by moving upper and lower mounting brackets as shown in Fig. 2-2-3. Remove the M6 bracket screws, move the brackets, then secure the brackets using the M5 case mounting screws. (The bracket screws are no longer required after changing the bracket mounting position.)

Quantity of mounting screw

Voltage series	Inverter type	Bracket screws	Case mounting screws
230V	FRN040G11S-2UX to FRN100G11S-2UX FRN040P11S-2UX to FRN125P11S-2UX	5	5
	FRN125G11S-2UX FRN125P11S-2UX	6	6
460V	FRN040G11S-4UX to FRN250G11S-4UX FRN040P11S-4UX to FRN300P11S-4UX	5	5
	FRN300G11S-4UX to FRN350G11S-4UX FRN350P11S-4UX to FRN400P11S-4UX	6	6

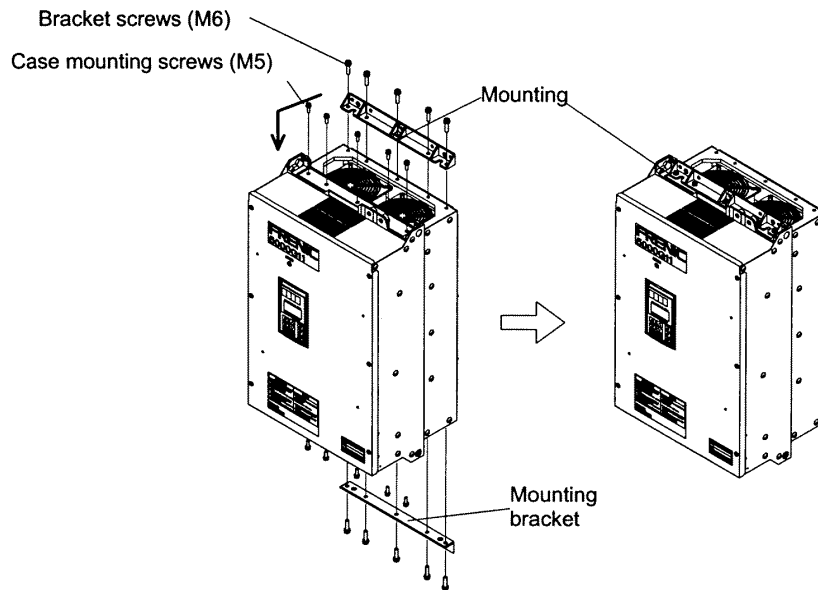

Fig. 2-2-3

⑦ For inverters of 30HP or less, remove the ventilating covers if ambient temperature exceeds +40°C(104°F)

(1) Removing the ventilating covers

One ventilating cover is mounted on top of the inverter and two or three are mounted at the bottom. Remove the surface cover, then remove ventilating covers by popping out the cover inserts as shown in Fig.2-2-4.

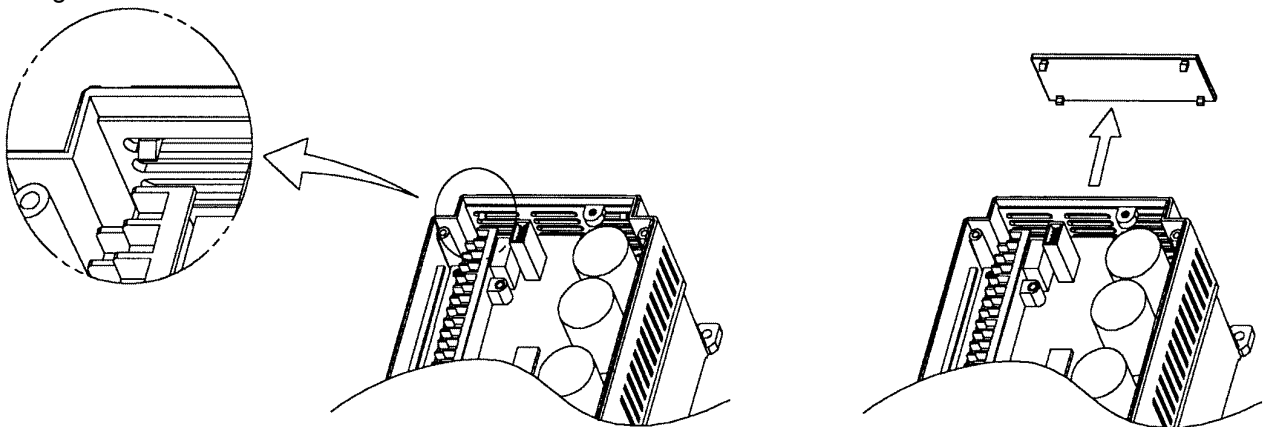



Fig. 2-2-4 Removing the ventilating cover

2-3 Connection

Remove the surface cover before connecting the terminal blocks as follows.

2-3-1 Basic connection

- ① Always connect power to the L1/R, L2/S, and L3/T main circuit power terminals of the inverter.
Connecting power to another terminal will damage the inverter. Check that the power voltage is within the maximum allowable voltage marked on the nameplate, etc.
- ② Always ground the ground terminal to prevent disasters such as fire or electric shock and to minimize noise.
- ③ Use a reliable crimp terminal for connection between a terminal and a cable.
- ④ After terminating the connection(wiring), confirm the following:
 - a. Confirm that the connection is correct.
 - b. Confirm that all necessary connections have been made.
 - c. Confirm that there is no short-circuit or ground fault between terminals and cables.
- ⑤ Connection modification after power-on
The smoothing capacitor in the direct current portion of the main circuit cannot be discharged immediately after the power is turned off. To ensure safety, use a multimeter to check that the voltage of the direct current (DC) is lowered to the safety range (25V DC or less) after the charge lamp goes off. Also, confirm that the voltage is zero before short-circuiting. The residual voltage (electric charge) may causesparks.

 WARNING	<ul style="list-style-type: none">• Always connect a ground wire. <p>Electric shock or fire may result.</p> <ul style="list-style-type: none">• Ensure that a licensed specialist performs all wiring works.• Confirm that the power is turned off (open) before commencing wiring operations. <p>Electrical shock may result.</p>
--	---

Basic Connection Diagram (Sink Logic)

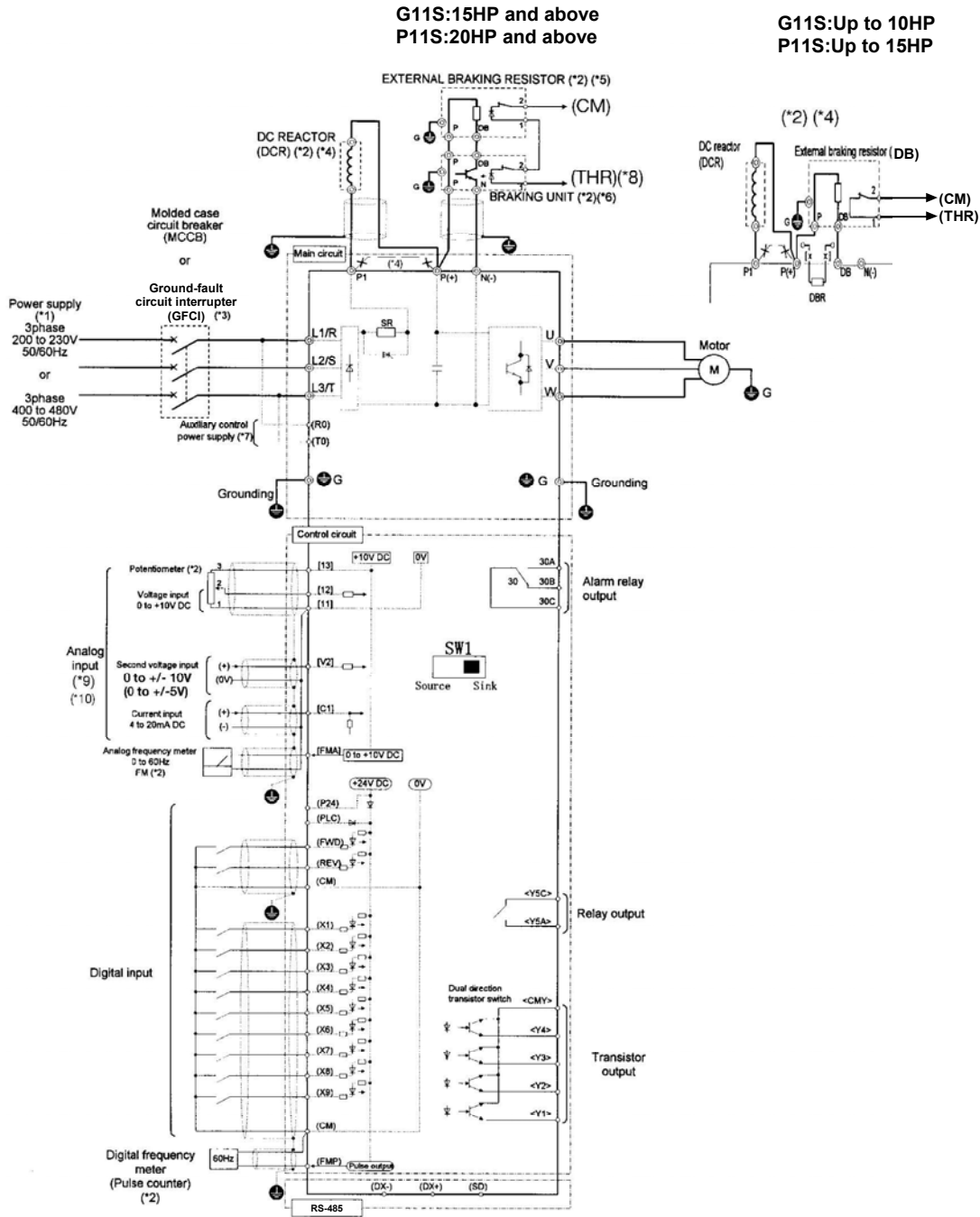

Fig.2-3-1

Note: The control circuit common terminals [11], (CM) and <CMY> are isolated

- (*1) Use a drive with rated voltage matching the power supply voltage.
- (*2) Use as required.
- (*3) Use this peripheral device when necessary.
- (*4) Remove the jumper wire (*4) between P1 and P(+) before connecting a DC REACTOR.
- (*5) Be sure to use the braking unit (option)(*6) when connecting the external braking resistor (option)(*5)
- (*6) Connect the braking unit to P(+) and N(-). The auxiliary terminals [1] and [2] have polarity. Connect them as shown in the figure above.
- (*7) The drive can be operated without connecting the auxiliary control power supply.
- (*8) Terminal (X1) to (X9) can be set to 9 (THR) - Braking unit thermal trip input.
- (*9) If using V2 or C1, as a reference signal, they must be used exclusively.
- (*10) It is possible to input voltage signals (0 to +10 VDC or 0 to +5 VDC) to terminals [12] [11] instead of the potentiometer.

Basic Connection Diagram to PLC (Sink Logic)

G11S:15HP and above
P11S:20HP and above

G11S:Up to 10HP
P11S:Up to 15HP

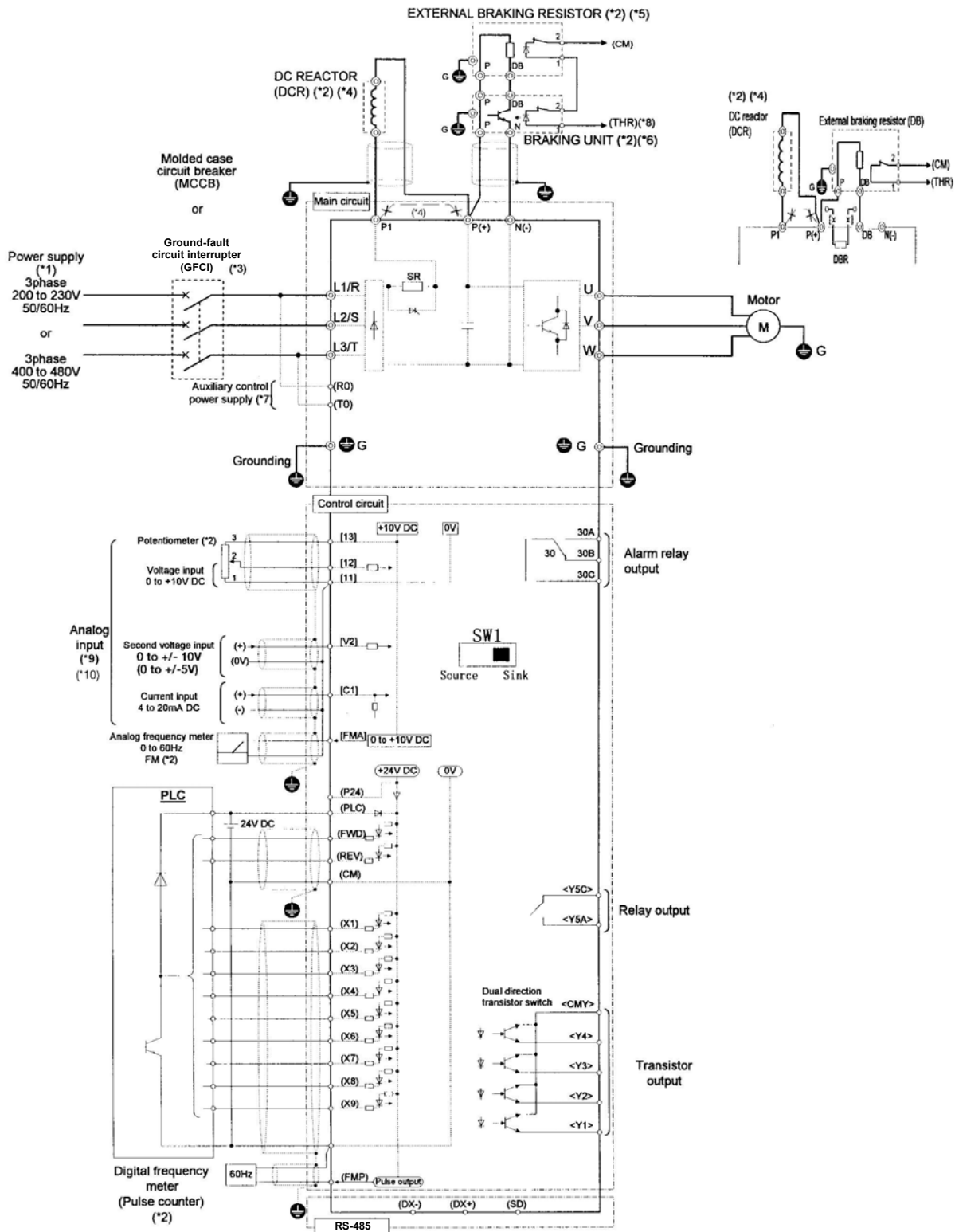

Fig.2-3-2

Basic Connection Diagram (Source Logic, Typically used in Europe)

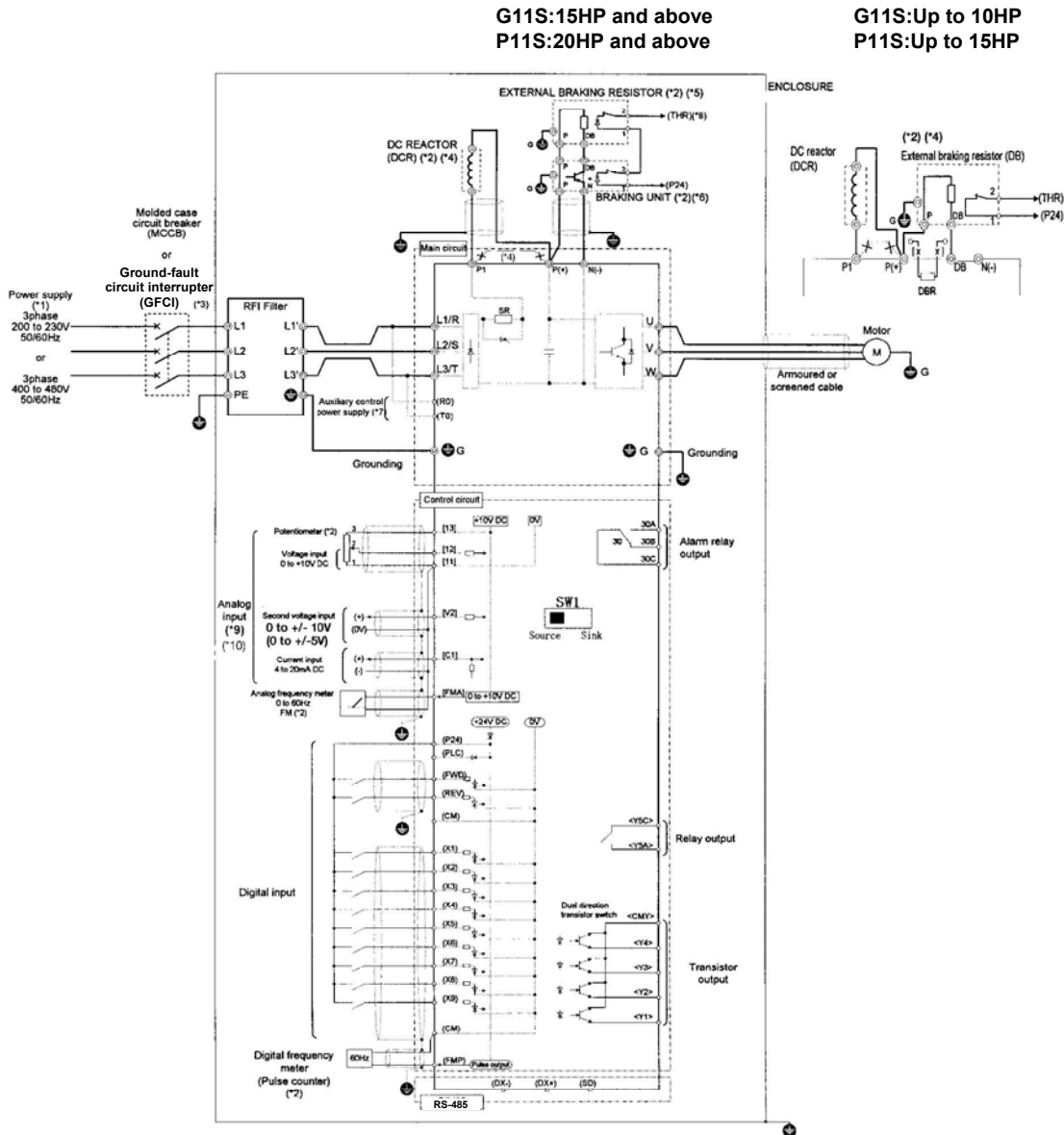

Fig.2-3-3

Note: The control circuit common terminals [11], (CM) and <CMY> are isolated

- (*1) Use a drive with rated voltage matching the power supply voltage.
- (*2) Use as required.
- (*3) Use this peripheral device when necessary.
- (*4) Remove the jumper wire (*4) between P1 and P(+) before connecting a DC REACTOR.
- (*5) Be sure to use the braking unit (option)(*6) when connecting the external braking resistor (option)(*5)
- (*6) Connect the braking unit to P(+) and N(-). The auxiliary terminals [1] and [2] have polarity. Connect them as shown in the figure above.
- (*7) The drive can be operated without connecting the auxiliary control power supply.
- (*8) Terminal (X1) to (X9) can be set to 9 (THR) - Braking unit thermal trip input.
- (*9) If using V2 or C1, as a reference signal, they must be used exclusively.
- (*10) It is possible to input voltage signals (0 to +10 VDC or 0 to +5 VDC) to terminals [12] [11] instead of the potentiometer

Basic Connection Diagram to PLC (Source logic, Typically used in Europe)

G11S:15HP and above
P11S:20HP and above

G11S:Up to 10HP
P11S:Up to 15HP

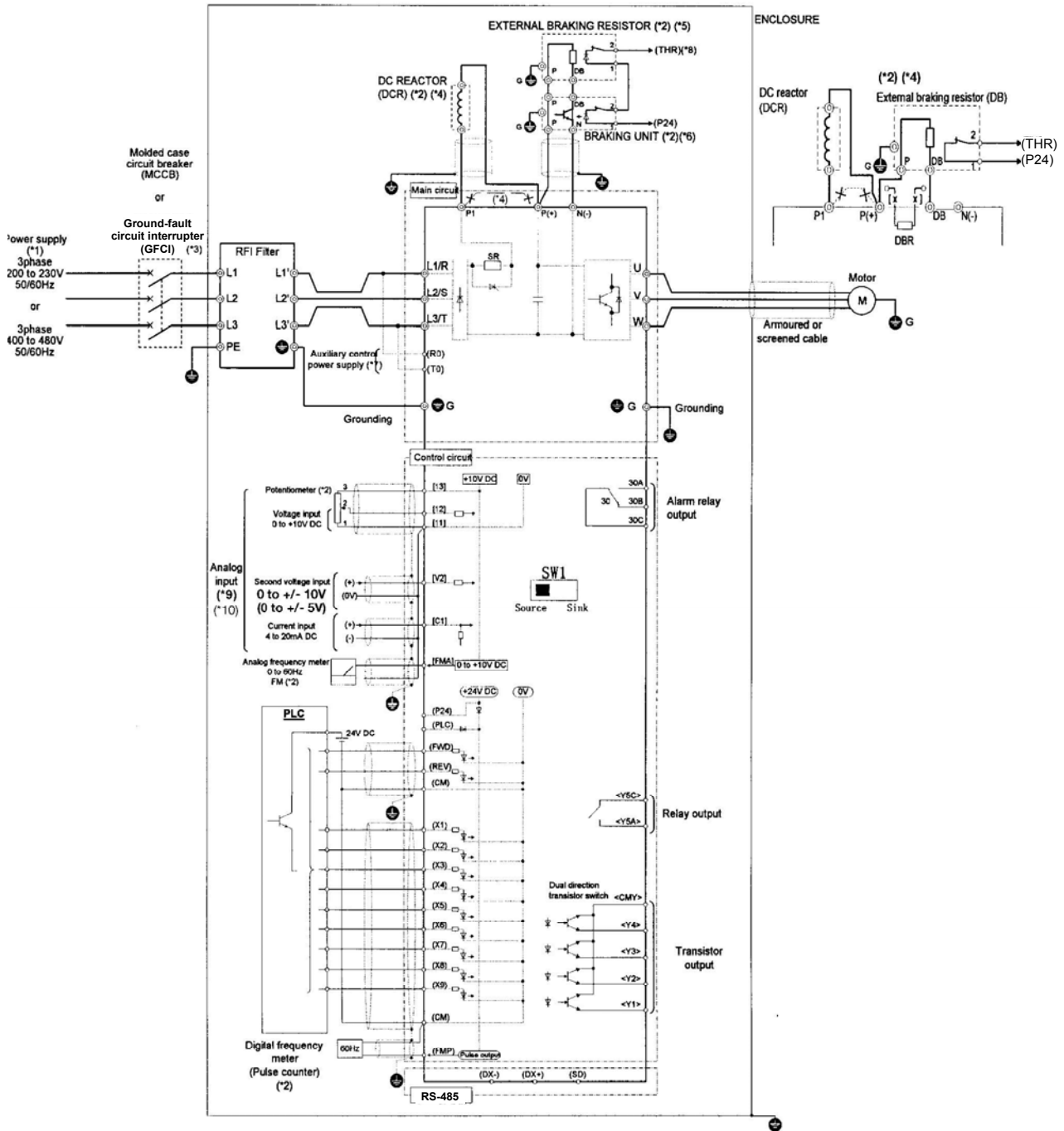



Fig.2-3-4

2-3-2 Connecting the main circuit and ground terminals

Table 2-3-1 Functions of main circuit terminals and ground terminals

Symbol	Terminal name	Description
L1/R, L2/S, L3/T	Main circuit power terminal	Connects a 3-phase power supply.
U, V, W	Inverter output terminal	Connects a 3-phase motor.
R0, T0	Auxiliary control-power input terminal	Connects a backup AC power supply to the control circuit. (Not supported for inverter of 1HP or less)
P1, P (+)	DC reactor connecting terminal	Connects the optional power-factor correcting DC reactor.
P (+), DB	External braking resistor connecting terminal	Connects the optional external braking resistor. (For inverter of 10HP or less)
P (+), N (-)	DC link circuit terminal	Supplies DC link circuit voltage to the external braking unit (option) or power regeneration unit (option).
 G	Inverter ground terminal	Grounds the inverter chassis (case) to the earth.

(1) Main circuit power terminals (L1/R, L2/S, L3/T)

- ① Connect these terminals to the power supply via a molded-case circuit breaker or a ground-fault circuit interrupter for circuit (wiring) protection. Phase-sequence matching is unnecessary.
- ② To ensure safety, a magnetic contactor should be connected to disconnect the inverter from the power supply when the inverter protective function activates.
- ③ Use control circuit terminal FWD/REV or the RUN/STOP key on the keypad panel to start or stop the inverter. The main circuit power should be used to start or stop the inverter only if absolutely necessary and then should not be used more than once every hour.
- ④ If you need to connect these terminals to a single-phase power supply, please contact the factory.

(2) Inverter output terminals (U, V, W)

- ① Connect these terminals to a 3-phase motor in the correct phase sequence. If the direction of motor rotation is incorrect, exchange any two of the U, V, and W phases.
- ② Do not connect a power factor correction capacitor or surge absorber to the inverter output.
- ③ If the cable from the inverter to the motor is very long, a high-frequency current may be generated by stray capacitance between the cables and result in an overcurrent trip of the inverter, an increase in leakage current, or a reduction in current indication precision.

When a motor is driven by a PWM-type drive, the motor terminals may be subject to surge voltage generated by drive element switching. If the motor cable (with 460V series motors, in particular) is particularly long, surge voltage will deteriorate motor insulation. To prevent this, use the following guidelines:

Inverters 7.5 HP and larger			
Motor Insulation Level	1000V	1300V	1600V
460 VAC Input Voltage	66 ft (20 m)	328 ft (100 m)	1312 ft (400 m) *
230 VAC Input Voltage	1312 ft (400 m) *	1312 ft (400 m) *	1312 ft (400 m) *

Inverters 5 HP and smaller			
Motor Insulation Level	1000V	1300V	1600V
460 VAC Input Voltage	66 ft (20 m)	165 ft (50 m) *	165 ft (50 m) *
230 VAC Input Voltage	328 ft (100 m) *	328 ft (100 m) *	328 ft (100 m) *

* For this case the cable length is determined by secondary effects and not voltage spiking.

Note: When a motor protective thermal O/L relay is inserted between the inverter and the motor, the thermal O/L relay may malfunction (particularly in the 460V series), even when the cable length is 165 feet (50m) or less. To correct, insert a filter or reduce the carrier frequency. (Use function code "F26 Motor sound".)

(3) Auxiliary control-power input terminals (R0 and T0)

The inverter operates even if power is not provided to these terminals.

If a protective circuit operates and the magnetic contactor on the inverter power side is opened (off), the inverter control circuit power, the alarm output (30A, B, and C), and the keypad panel display goes off. To prevent this, the same AC power as the main circuit AC power must be supplied (as auxiliary control power) to the auxiliary control-power input terminals (R0 and T0).

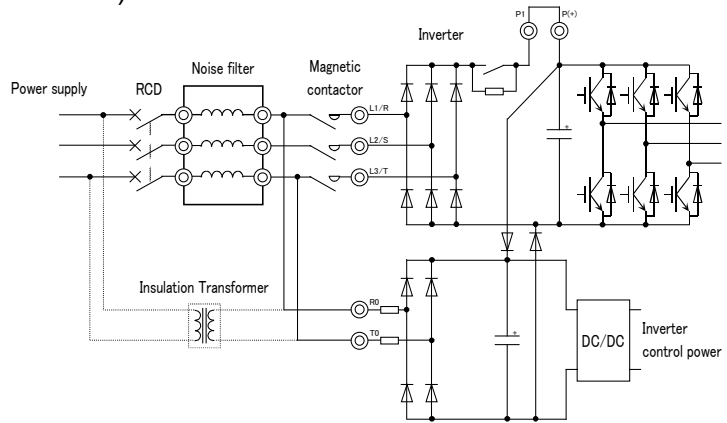

Fig. 2-3-5 Connecting the auxiliary control-power input terminals

- ① To ensure effective noise reduction when using a radio noise filter, the output power from the filter must go to the auxiliary control-power input terminals.

If these terminals are connected to the input side of the filter, the noise reduction effect deteriorates.

- ② When the RCD (Residual-current Protective Device) is installed (G11S:30HP or less), the terminal R0 and T0 should be connected to the OUTPUT side of the RCD. If they are connected to the input side of the RCD, RCD will be malfunction because the power supply of the inverter is three phase and the terminal R0 and T0 is single phase.

When the terminal R0 and T0 are connected to the INPUT side of the RCD, the insulation transformer is required to install as shown on the Fig. 2-3-5.

(4) DC reactor connecting terminals (P1 and P (+))

- ① Before connecting a power-factor correcting DC reactor (optional) to these terminals, remove the factory-installed jumper.
- ② If a DC reactor is not used, do not remove the jumper.

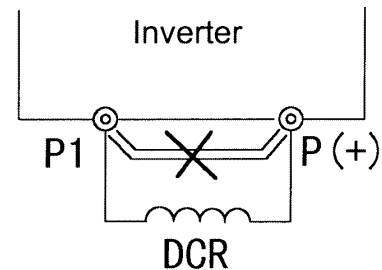

Fig. 2-3-6

Note: For inverter of 100HP or more, the DC reactor is provided as a separate standard component and should always be connected to the terminals.

(5) External braking-resistor connecting terminals (P (+) and DB) (G11S:10HP or less)

For the G11S of 10HP or less, a built-in braking resistor is connected to terminals P (+) and DB.

If this braking resistor does not provide sufficient thermal capacity (e.g., in highly repetitive operation or heavy inertia load operation), an external braking resistor (option) must be mounted to improve braking performance.

- ① Remove the built-in braking resistor from terminals P(+) and DB. Insulate the resistor-removed terminals with adhesive insulation tape, etc.
- ② Connect terminals P(+) and DB of the external braking resistor to terminals P(+) and DB of the inverter.
- ③ The wiring (cables twisted or otherwise) should not exceed 16ft (5m).

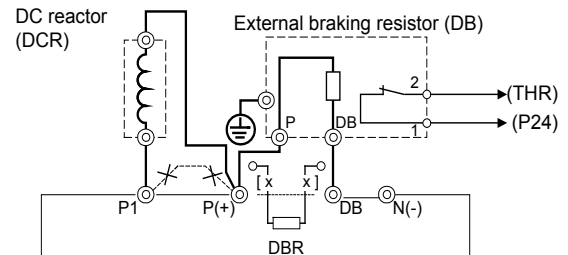

Fig. 2-3-7 Connection (G11S:10HP or less)

(6) DC link circuit terminals (P (+) and N (-))

The G11S inverter of 15HP or more does not contain a drive circuit for the braking resistor. To improve braking performance, an external braking unit (option) and an external braking resistor (option) must be installed.

- ① Connect terminals P(+) and N(-) of the braking unit to terminals P(+) and N(-) of the inverter. The wiring (cables twisted or otherwise) should not exceed 16ft(5m).
- ② Connect terminals P(+) and DB of the braking resistor to terminals P(+) and DB of the braking unit. The wiring (cables twisted or otherwise) should not exceed 33ft (10m). When terminals P (+) and N (-) of the inverter are not used, leave terminals open. If P (+) is connected to N (-) or the braking resistor is connected directly, the resistor will break.

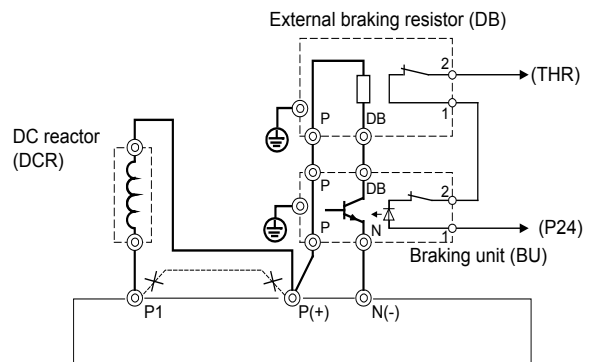

Fig. 2-3-8 Connection (G11S:15HP or more)

- ③ Auxiliary contacts 1 and 2 of the braking unit have polarity. To connect the power regeneration unit, refer to the "Power Regeneration Unit Instruction Manual".

(7) Inverter ground terminal

To ensure safety and noise reduction, always ground the inverter ground terminal. Also, metal frames of electrical equipment must be grounded as specified in the Electric Facility Technical Standard.

The connection procedure is as follows:

- ① Ground metal frames to a ground terminal (Ground resistance:10 Ω or less).
- ② Use a suitable cable (short and thick) to connect the inverter system to the ground terminal.

(8) Auxiliary power switching connector (CN UX) (for inverter of 40HP or more)

When an inverter of 40HP or more requires a main circuit power voltage as listed in Table 2-3-2, disconnect auxiliary power switching connector CN UX from U1 and connect to U2. For the switching method, see Fig. 2-3-11.

Table 2-3-2 Main circuit power voltage requiring auxiliary power switching connector switching

Frequency [Hz]	Power voltage range [VAC]
50	380-398
60	380-430

 CAUTION	<ul style="list-style-type: none">• Check that the number of phases and rated voltage of this product match those of the AC power supply.• Do not connect the AC power supply to the output terminals (U, V, W). Injury may result.• Do not connect a braking resistor directly to the DC terminals (P[+] and N[-]). Fire may result.
--	---

(9) Fan power switching connector (CN RXTX) (for inverter of 40HP or more)

G11S without options supports DC power input via DC common connection by connecting the power regeneration converter (RHC series) as shown in Fig. 2-3-10.

For details, refer to technical documentation.

The inverter of 40HP or more contains an AC-powered component (e.g., AC cooling fan).

To use the inverter using DC power input, switch the fan power switching connector (CN RTXT) inside the inverter to the R0-T0 side and provide AC power to the R0 and T0 terminals. (See Fig. 2-3-9.)

For the switching method, see Fig. 2-3-11.

Note:

In the standard state, the fan power switching connector (CN RXTX) is connected to the L1/R-L3/T side.

When DC power input is not used, do not switch this connector.

The same AC voltage as the main circuit power voltage must be supplied to the auxiliary control-power input terminals (R0 and T0). If not supplied, the fan does not rotate and the inverter will overheat (OH1).

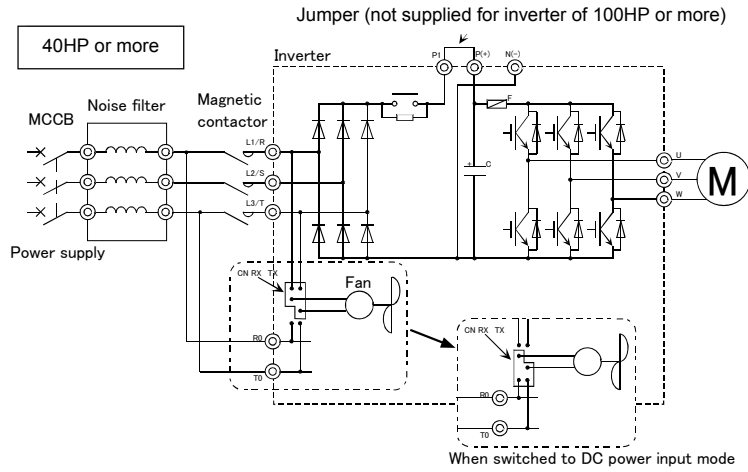

Fig. 2-3-9 Fan power switching

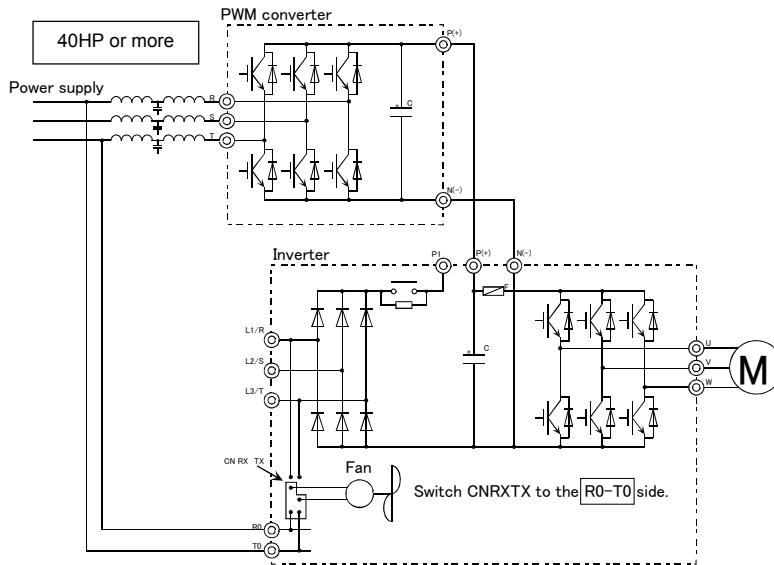

Fig. 2-3-10A Example of connection by combination with power regeneration converter(40HP or more)

Note:

To connect the power regeneration converter to an inverter of 30HP or less, do not connect the power supply directly to the auxiliary control-power input terminals (R0 and T0) of the inverter. However, if such a connection is required, insulate these input terminals from the main power of the power regeneration converter with an insulation transformer. The connection example of a power regeneration unit is provided in the "Power Regeneration Unit Instruction Manual".

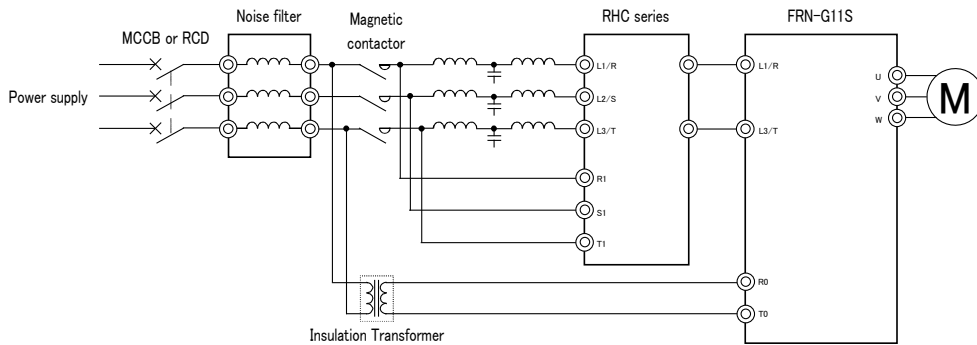
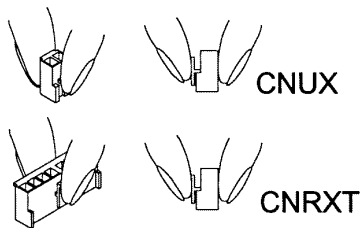
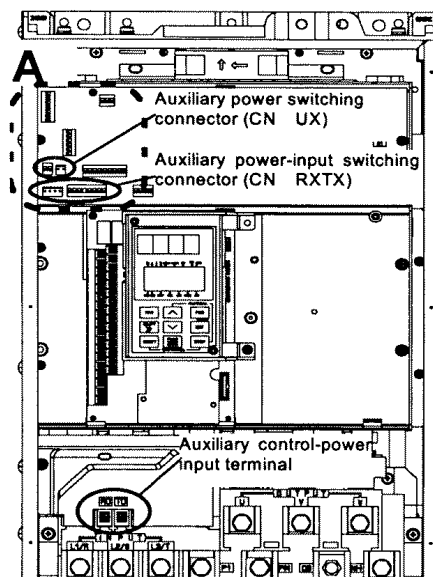

Fig. 2-3-10B Example of connection by combination with power regeneration converter (30HP or less)

The switching connectors are mounted on the power PCB above the control PCB as shown on the right.



Note:
To remove a connector, unlock the connector (using the locking mechanism) and pull. To mount a connector, push the connector until it click locks.



FRN040G11S-4UX to FRN150G11S-4UX

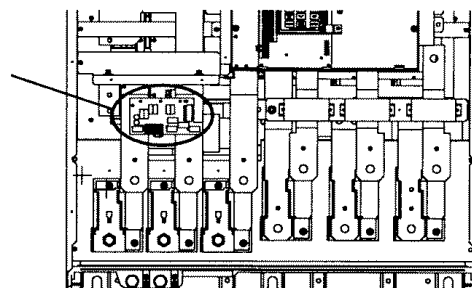

FRN200G11S-4UX to FRN350G11S-4UX

Auxiliary control-power input terminal

<Enlarged view of part A>

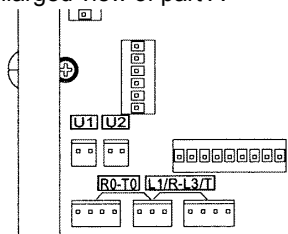

When shipped from the factory, CN UX is connected to the **U1** side and CN RXTX is connected to the **L1/R-L3/T** side.

<Oblique view of part A>

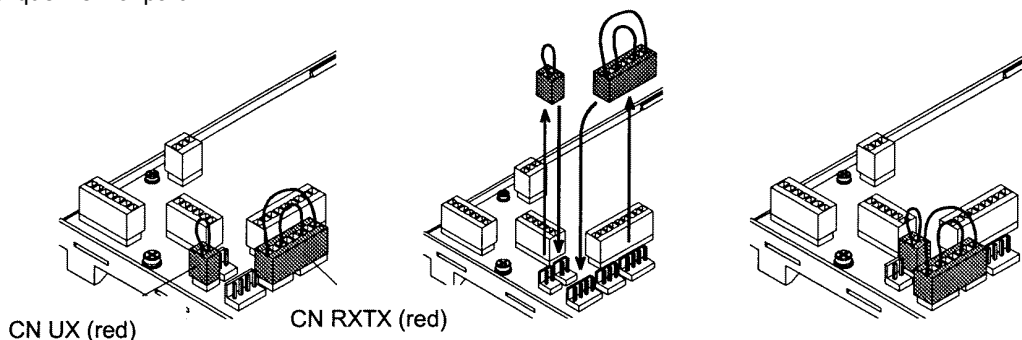

Factory shipment status Connector removal After connector switching.

CN UX : **U1**
CN RXTX : **L1/R-L3/T**

In this figure the power voltage is 380 to 398V AC, 50Hz (or 380 to 430V AC, 60Hz) and the inverter is used in DC power input mode.

Fig. 2-3-11 Power switching connectors (only for 40HP or more)

2-3-3 Connecting the control terminals

Table 2-3-3 lists the functions of the control circuit terminals. A control circuit terminal should be connected according to the setting of its functions.

Table 2-3-3

Classification	Terminal symbol	Terminal name	Function																				
Analog input	13	Potentiometer power supply	Used for +10V DC power supply for frequency setting POT (variable resistor of 1 to 5kΩ)																				
	12	Voltage input	① Frequency is set according to the analog input voltage supplied from an external circuit. - 0 to +10V DC/0 to 100% - Reversible operation using positive and negative signals:0 to +/-10V DC/0 to 100% - Reverse operation: +10 to 0V DC/0 to 100% ② The feedback signal for PID control is input. ③ The analog input value from the external circuit is used for torque control. (P11S does not support this function.) * Input resistance: 22kΩ																				
	V2	Voltage input	Frequency is set according to the analog input voltage supplied from an external circuit - 0 to +10V DC/0 to 100% - Reverse operation:+10 to 0V DC/0 to 100% * It can be used only one terminal "V2" or "C1" alternatively * Input resistance:22kΩ																				
	C1	Current input	① Frequency is set according to the analog input current supplied from an external circuit. - 4 to 20mA DC/0 to 100% - Reverse operation:20 to 4mA DC/0 to 100% ② The feedback signal for PID control is input. ③ PTC thermistor input * It can be used only one terminal "V2" or "C1" alternatively. * Input resistance:250Ω																				
	11	Analog input common	Common terminal for analog input signals																				
Digital input	FWD	Forward operation/stop command	Used for forward operation (when FWD-CM is on) or deceleration and stop (when FWD-CM is off)																				
	REV	Reverse operation/stop command	Used for reverse operation (when REV-CM is on) or deceleration and stop (when REV-CM is off)																				
	X1	Digital input 1	The coast-to-stop command, external alarm, alarm reset, multistep frequency selection, and other functions (from an external circuit) can be assigned to terminals X1 to X9. For details, see "Setting the Terminal Functions E01 to E09" in Section 5.2, "Details of Each Function." <Specifications of digital input circuit> *																				
	X2	Digital input 2																					
	X3	Digital input 3																					
	X4	Digital input 4																					
	X5	Digital input 5																					
	X6	Digital input 6																					
	X7	Digital input 7																					
	X8	Digital input 8																					
	X9	Digital input 9																					
		<table border="1"> <thead> <tr> <th>Item</th> <th>min.</th> <th>typ.</th> <th>max.</th> </tr> </thead> <tbody> <tr> <td rowspan="2">Operating voltage</td> <td>ON level</td> <td>2V</td> <td>-</td> <td>2V</td> </tr> <tr> <td>OFF level</td> <td>22V</td> <td>24V</td> <td>27V</td> </tr> <tr> <td>Operating current at ON level</td> <td>-</td> <td>3.2mA</td> <td>4.5mA</td> </tr> <tr> <td>Allowable leakage current at OFF level</td> <td>-</td> <td>-</td> <td>0.5mA</td> </tr> </tbody> </table>	Item	min.	typ.	max.	Operating voltage	ON level	2V	-	2V	OFF level	22V	24V	27V	Operating current at ON level	-	3.2mA	4.5mA	Allowable leakage current at OFF level	-	-	0.5mA
Item	min.	typ.	max.																				
Operating voltage	ON level	2V	-	2V																			
	OFF level	22V	24V	27V																			
Operating current at ON level	-	3.2mA	4.5mA																				
Allowable leakage current at OFF level	-	-	0.5mA																				
CM	Common terminal	Common terminal for Digital input and FMP terminals																					
P24	Control Unit power Supply	+24VDC power supply for control input. Maximum output current 100mA																					
PLC	PLC signal power	Used to connect power supply for PLC output signals (rated voltage 24(22 to 27) V DC) at source logic operation.																					
Analog output	FMA (11: Common terminal)	Analog monitor	Outputs monitor signal using analog DC voltage 0 to +10V DC. The meaning of this signal is one of the following: -Output frequency (before slip compensation) -Power consumption -Output frequency (after slip compensation) -PID feedback value -Output current -PG feedback value -Output voltage -DC link circuit voltage -Output torque -Universal AO -Load factor *Connectable impedance:5kΩ minimum																				

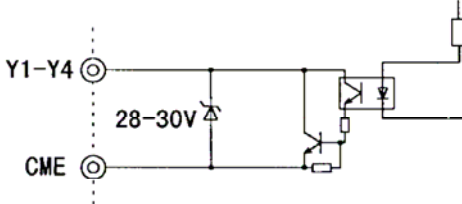
Pulse output	FMP (CM: Common terminal)	Frequency monitor (pulse waveform output)	Outputs a monitor signal using the pulse waveform. This signal has the same function as the FMA signal.																					
Transistor output	Y1	Transistor output1	<p>A running signal, frequency equivalence signal, overload early warning signal, and other signals from the inverter are output (as transistor output) to arbitrary ports. For details, see "Setting the Terminal Functions E20 to E23" in Section 5.2, "Details of Each Function."</p> <p><Specifications of transistor output circuit></p> <p>*</p> <table border="1"> <thead> <tr> <th>Item</th> <th>min.</th> <th>typ.</th> <th>max.</th> </tr> </thead> <tbody> <tr> <td rowspan="2">Operating voltage</td> <td>ON level</td> <td>-</td> <td>2V</td> <td>3V</td> </tr> <tr> <td>OFF level</td> <td>-</td> <td>24V</td> <td>27V</td> </tr> <tr> <td>Maximum load current at ON level</td> <td>-</td> <td>-</td> <td>50mA</td> </tr> <tr> <td>Leakage current at OFF level</td> <td>-</td> <td>-</td> <td>0.1mA</td> </tr> </tbody> </table> 	Item	min.	typ.	max.	Operating voltage	ON level	-	2V	3V	OFF level	-	24V	27V	Maximum load current at ON level	-	-	50mA	Leakage current at OFF level	-	-	0.1mA
	Item	min.		typ.	max.																			
	Operating voltage	ON level		-	2V	3V																		
		OFF level		-	24V	27V																		
	Maximum load current at ON level	-		-	50mA																			
Leakage current at OFF level	-	-	0.1mA																					
Y2	Transistor output2																							
Y3	Transistor output3																							
Y4	Transistor output4																							
CME	Transistor output common	Common terminal for transistor output signals. This terminal is insulated from terminals [CM] and [11].																						
Relay output	30A,30B,30C	Alarm output for any fault	If the inverter is stopped by an alarm (protective function), the alarm signal is output from the relay contact output terminal (1SPDT). Contact rating: 48V DC, 0.5A. An excitation mode (excitation at alarm occurrence or at normal operation) can be selected.																					
	Y5A,Y5C	Multipurpose-signal relay output	These signals can be output similar to the Y1 to Y4 signals above. The contact rating for any fault is the same as that of the alarm output above. An excitation mode (excitation at alarm occurrence or at normal operation) can be selected.																					
Communication	DX+, DX-	RS-485 communication input-output	Input-output signal terminals for RS-485 communication. UP to 31 inverters can be connected using the daisy chain method.																					
	SD	Communication-cable shield connection terminal	Terminal for connecting the shield of a cable. The terminal is electrically floating.																					

(1) Analog input terminals (13,12,V2,C1,and 11)

- ① These terminals receive weak analog signals that may be affected by external noise. The cables must be as short as possible (66ft (20m) or less), must be shielded, and must be grounded in principle. If the cables are affected by external induction noise, the shielding effect may be improved by connecting the shield to terminal [11].
- ② If contacts must be connected to these circuits, twin (bifurcated type) contacts for handling weak signals must be used. A contact must not be connected to terminal [11].
- ③ If an external analog signal output device is connected to these terminals, it may malfunction as a result of inverter noise. To prevent malfunction, connect a ferrite core or capacitor to the external analog signal output device.

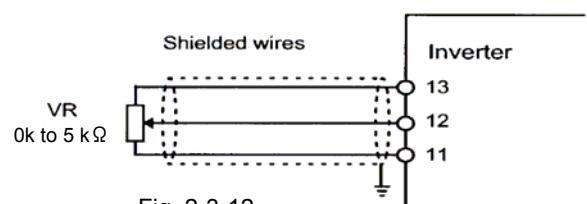

Fig. 2-3-12

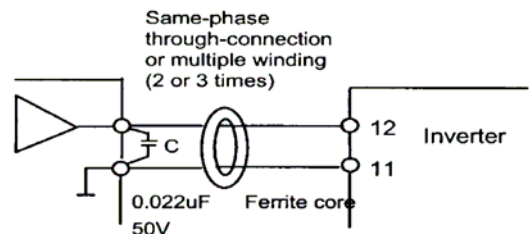

Fig. 2-3-13 Example of noise prevention

(2) Digital input terminals (FWD, REV, X1 to X9 and CM)

- ① Digital input terminals (e.g., FWD, REV, X1 to X9) are generally turned on or off by connecting or disconnecting the line to or from the CM terminal. If Digital input terminals are turned on or off by switching the open collector output of PLC using an external power supply, a resulting bypass circuit may cause the inverter to malfunction. To prevent a malfunction, connect the PLC terminal as shown in Fig. 2-3-14.
- ② When using a contact input, a relay having highly reliable contact must be used.
Example: Fuji Electric Control Relay:HH54PW

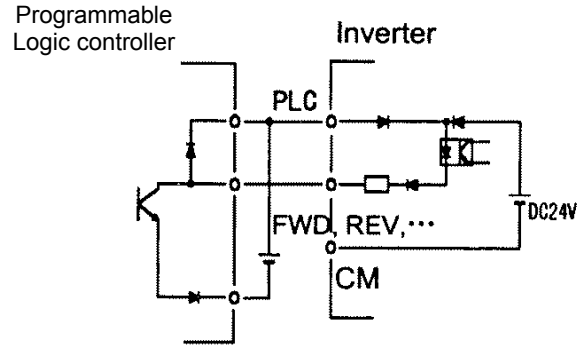



Fig. 2-3-14
Connection for External power supply

(3) Transistor output terminals (Y1 to Y4, CME)

- ① To connect a control relay, connect a surge absorbing diode to both ends of its exciting coil.

(4) Others

- ① To prevent a malfunction as a result of noise, control terminal cables must be placed as far as possible from the main circuit cables.
- ② The control cables inside the inverter must be secured to prevent direct contact with live section (e.g., main-circuit terminal block) of the main circuit.

 WARNING	Control lines generally do not have enhanced insulation. If the insulation of a control line is damaged, the control signals may be exposed to high voltage in the main circuit. The Low Voltage Directive in Europe also restricts the exposure to high voltage. Electric shock may result
 CAUTION	The inverter, motor, and cables generate noise. Check that the ambient sensors and devices do not malfunction. Accident may result.

(5) Wiring of control circuit (inverter of 40HP or more)

- ① Pull out the control circuit wiring along the left panel as shown in Fig. 2-3-15.
- ② Secure the cable to cable binding hole A (on the left wall of the main circuit terminal block) using a cable-tie (e.g., insulock). The cable-tie must not exceed 0.14inch (3.5mm) in width and 0.06inch (1.5mm) in thickness.
- ③ When the optional PC board is mounted, the signal lines must be secured to cable binding hole B.

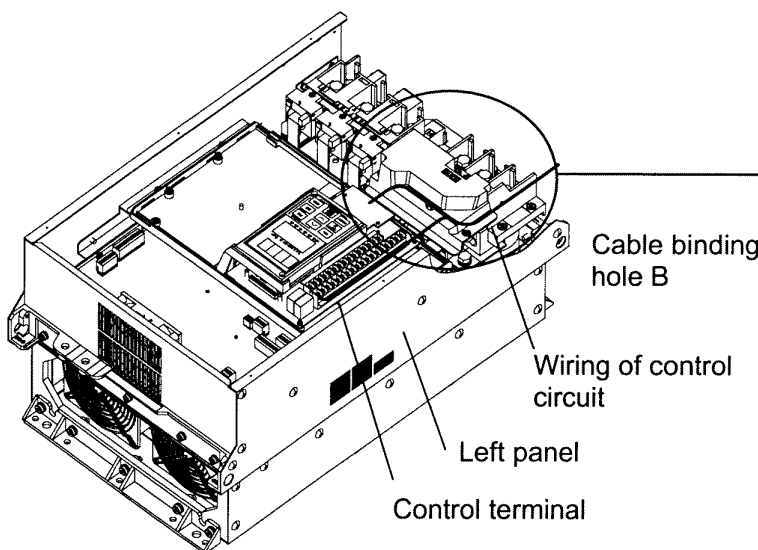

Fig. 2-3-15 The wiring route of the control circuit

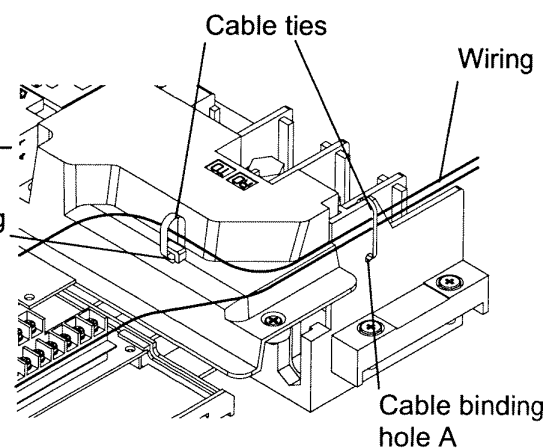

Fig. 2-3-16 The securing positions of the control-circuit line of inverter (40HP or more)

2-3-4 Terminal arrangement

(1) Main circuit terminals

<p>FRNF25 to 001G11S-2UX FRNF50 to 001G11S-4UX</p> <p style="text-align: right;">Screw size M3.5</p> <div style="display: flex; justify-content: space-around; border: 1px solid black; padding: 2px;"> L1/RL2/SL3/TDBP1P(+)N(-)UVW </div> <div style="display: flex; justify-content: space-around; margin-top: 10px;"> <div style="border: 1px solid black; padding: 2px;">G</div> <div style="border: 1px solid black; padding: 2px;">G</div> </div> <p style="text-align: right;">Screw size M3.5</p>	<p>FRN100G11S-2UX /FRN125P11S-2UX</p> <p style="text-align: right;">Screw size M4</p> <div style="display: flex; justify-content: space-around; border: 1px solid black; padding: 2px;"> R0T0 </div> <div style="display: flex; justify-content: space-around; border: 1px solid black; padding: 2px; margin-top: 10px;"> L1/RL2/SL3/TP1P(+)N(-)UVW </div> <div style="display: flex; justify-content: space-around; margin-top: 10px;"> <div style="border: 1px solid black; padding: 2px;">G</div> <div style="border: 1px solid black; padding: 2px;">G</div> </div> <p style="text-align: right;">Screw size G: M10 other terminals : M12</p>
<p>FRN002 to 005G11S-2UX FRN002 to 005G11S-4UX</p> <p style="text-align: right;">Screw size M3.5</p> <div style="display: flex; justify-content: space-around; border: 1px solid black; padding: 2px;"> R0T0 </div> <div style="display: flex; justify-content: space-around; border: 1px solid black; padding: 2px; margin-top: 10px;"> L1/RL2/SL3/TDBP1P(+)N(-)UVW </div> <div style="display: flex; justify-content: space-around; margin-top: 10px;"> <div style="border: 1px solid black; padding: 2px;">G</div> <div style="border: 1px solid black; padding: 2px;">G</div> </div> <p style="text-align: right;">Screw size M4</p>	<p>FRN125G11S-2UX /FRN150P11S-2UX FRN200 to 350G11S-4UX /FRN250 to 450P11S-4UX</p> <p style="text-align: right;">Screw size M4</p> <div style="display: flex; justify-content: space-around; border: 1px solid black; padding: 2px;"> R0T0 </div> <div style="display: flex; justify-content: space-around; border: 1px solid black; padding: 2px; margin-top: 10px;"> L1/RL2/SL3/TUVW </div> <div style="display: flex; justify-content: space-around; margin-top: 10px;"> <div style="border: 1px solid black; padding: 2px;">G</div> <div style="border: 1px solid black; padding: 2px;">G</div> </div> <p style="text-align: right;">Screw size G : M10 other terminals : M12</p>
<p>FRN007 to 010G11S-2UX /FRN007 to 015P11S-2UX FRN007 to 010G11S-4UX /FRN007 to 015P11S-4UX</p> <p style="text-align: right;">Screw size M3.5</p> <div style="display: flex; justify-content: space-around; border: 1px solid black; padding: 2px;"> R0T0 </div> <div style="display: flex; justify-content: space-around; border: 1px solid black; padding: 2px; margin-top: 10px;"> L1/RL2/SL3/TDBP1P(+)N(-)UVW </div> <div style="display: flex; justify-content: space-around; margin-top: 10px;"> <div style="border: 1px solid black; padding: 2px;">G</div> <div style="border: 1px solid black; padding: 2px;">G</div> </div> <p style="text-align: right;">Screw size M5</p>	<p>FRN400, 450 G11S-4UX/FRN500, 600 P11S-4UX</p> <p style="text-align: right;">Screw size M4</p> <div style="display: flex; justify-content: space-around; border: 1px solid black; padding: 2px;"> R0T0 </div> <div style="display: flex; justify-content: space-around; border: 1px solid black; padding: 2px; margin-top: 10px;"> L1/RL2/SL3/TP1UVW </div> <div style="display: flex; justify-content: space-around; margin-top: 10px;"> <div style="border: 1px solid black; padding: 2px;">G</div> <div style="border: 1px solid black; padding: 2px;">G</div> </div> <div style="display: flex; justify-content: space-around; margin-top: 10px;"> <div style="border: 1px solid black; padding: 2px;">P(+)</div> <div style="border: 1px solid black; padding: 2px;">P(+)</div> </div> <div style="display: flex; justify-content: space-around; margin-top: 5px;"> <div style="border: 1px solid black; padding: 2px;">N(-)</div> <div style="border: 1px solid black; padding: 2px;">N(-)</div> </div> <p style="text-align: right;">Screw size G = M10 Other terminals = M12</p>
<p>FRN015 to 030G11S-2UX /FRN020 to 030P11S-2UX FRN015 to 030G11S-4UX /FRN020 to 030P11S-4UX</p> <p style="text-align: right;">Screw size M3.5</p> <div style="display: flex; justify-content: space-around; border: 1px solid black; padding: 2px;"> R0T0 </div> <div style="display: flex; justify-content: space-around; border: 1px solid black; padding: 2px; margin-top: 10px;"> L1/RL2/SL3/TDBP1P(+)N(-)UVW </div> <div style="display: flex; justify-content: space-around; margin-top: 10px;"> <div style="border: 1px solid black; padding: 2px;">G</div> <div style="border: 1px solid black; padding: 2px;">G</div> </div> <p style="text-align: right;">Screw size M6</p>	<p>FRN500, 600 G11S-4UX/FRN700, 800 P11S-4UX</p> <p style="text-align: right;">Screw size M4</p> <div style="display: flex; justify-content: space-around; border: 1px solid black; padding: 2px;"> R0T0 </div> <div style="display: flex; justify-content: space-around; border: 1px solid black; padding: 2px; margin-top: 10px;"> L1/RL2/SL3/TP1P(+)N(-)UVW </div> <div style="display: flex; justify-content: space-around; margin-top: 10px;"> <div style="border: 1px solid black; padding: 2px;">G</div> <div style="border: 1px solid black; padding: 2px;">G</div> </div> <p style="text-align: right;">Screw size R0, T0 = M4 G = M10 Other terminals = M12</p>
<p>FRN040G11S-2UX /FRN040 to 050P11S-2UX FRN040 to 075G11S-4UX /FRN040 to 100P11S-4UX</p> <p style="text-align: right;">Screw size M4</p> <div style="display: flex; justify-content: space-around; border: 1px solid black; padding: 2px;"> R0T0 </div> <div style="display: flex; justify-content: space-around; border: 1px solid black; padding: 2px; margin-top: 10px;"> L1/RL2/SL3/TP1P(+)N(-)UVW </div> <div style="display: flex; justify-content: space-around; margin-top: 10px;"> <div style="border: 1px solid black; padding: 2px;">G</div> <div style="border: 1px solid black; padding: 2px;">G</div> </div> <p style="text-align: right;">Screw size M8</p>	<p>FRN040G11S-2UX /FRN040 to 050P11S-2UX FRN040 to 075G11S-4UX /FRN040 to 100P11S-4UX</p> <p style="text-align: right;">Screw size M4</p> <div style="display: flex; justify-content: space-around; border: 1px solid black; padding: 2px;"> R0T0 </div> <div style="display: flex; justify-content: space-around; border: 1px solid black; padding: 2px; margin-top: 10px;"> L1/RL2/SL3/TP1P(+)N(-)UVW </div> <div style="display: flex; justify-content: space-around; margin-top: 10px;"> <div style="border: 1px solid black; padding: 2px;">G</div> <div style="border: 1px solid black; padding: 2px;">G</div> </div> <p style="text-align: right;">Screw size G : M8 other terminals : M10</p>
<p>FRN050 to 075G11S-2UX /FRN060 to 100P11S-2UX FRN100 to 150G11S-4UX /FRN125 to 200P11S-4UX</p> <p style="text-align: right;">Screw size M4</p> <div style="display: flex; justify-content: space-around; border: 1px solid black; padding: 2px;"> R0T0 </div> <div style="display: flex; justify-content: space-around; border: 1px solid black; padding: 2px; margin-top: 10px;"> L1/RL2/SL3/TP1P(+)N(-)UVW </div> <div style="display: flex; justify-content: space-around; margin-top: 10px;"> <div style="border: 1px solid black; padding: 2px;">G</div> <div style="border: 1px solid black; padding: 2px;">G</div> </div> <p style="text-align: right;">Screw size G : M8 other terminals : M10</p>	<p>FRN050 to 075G11S-2UX /FRN060 to 100P11S-2UX FRN100 to 150G11S-4UX /FRN125 to 200P11S-4UX</p> <p style="text-align: right;">Screw size M4</p> <div style="display: flex; justify-content: space-around; border: 1px solid black; padding: 2px;"> R0T0 </div> <div style="display: flex; justify-content: space-around; border: 1px solid black; padding: 2px; margin-top: 10px;"> L1/RL2/SL3/TP1P(+)N(-)UVW </div> <div style="display: flex; justify-content: space-around; margin-top: 10px;"> <div style="border: 1px solid black; padding: 2px;">G</div> <div style="border: 1px solid black; padding: 2px;">G</div> </div> <p style="text-align: right;">Screw size G : M8 other terminals : M10</p>

(2) Control circuit terminals

30C	30A
30B	Y5A
Y5C	CMY
Y4	Y3
Y2	Y1
11	C1
12	FMA
13	FMP
V2	PLC
CM	X1
CM	X2
FWD	X3
REV	X4
P24	X5
P24	X6
DX -	X7
DX +	X8
SD	X9

2-3-5 Applicable equipment and wire size for main circuit

Voltage	Inverter type	MCCB or RCD/GFCI Rated current(A)		Required torque [lb-inch](N·m)			Wire range [AWG] (mm ²)		
		W/ DCR	W/o DCR	Main terminal	Auxiliary control-power	Control	L1/R,L2/S,L3/T U,V,W	Auxiliary control-power	Control
3-phase 230V	FRNF25G11S-2UX	5	5	10.6(1.2)	-		16 (1.3)	-	
	FRNF50G11S-2UX	5	5						
	FRN001G11S-2UX	5	10						
	FRN002G11S-2UX	10	15	15.9(1.8)					
	FRN003G11S-2UX	10	20						
	FRN005G11S-2UX	20	30						
	FRN007G11S-2UX	30	50	31.0(3.5)					
	FRN007,010P11S-2UX	30,40	50,75						
	FRN010G11S-2UX	40	75						
	FRN015P11S-2UX	50	100	51.3(5.8)	10.6(1.2)	6.2(0.7)		16(1.3)	24 (0.2)
	FRN015G11S-2UX	50	100						
	FRN020P11S-2UX	75	125						
	FRN020G11S-2UX	75	125	119(13.5)					
	FRN025P11S-2UX	100	150						
	FRN025G11S-2UX	100	150						
	FRN030P11S-2UX	100	175	239(27)					
	FRN030G11S-2UX	100	175						
	FRN040G11S/P11S-2UX	150	200						
	FRN050P11S-2UX	175	250	425(48)					
	FRN050G11S-2UX	175	250						
FRN060G11S/P11S-2UX	200	300							
FRN075G11S/P11S-2UX	250	350	119(13.5)						
FRN100P11S-2UX	350	-							
FRN100G11S-2UX	350	-							
FRN125G11S/P11S-2UX	400	-	239(27)						
FRN150P11S-2UX	500	-							
FRN150G11S-2UX	500	-							
3-phase 460V	FRNF50G11S-4UX	5	5	10.6(1.2)	-		16 (1.3)	-	
	FRN001G11S-4UX	5	5						
	FRN002G11S-4UX	5	10						
	FRN003G11S-4UX	5	15	15.9(1.8)					
	FRN005G11S-4UX	10	20						
	FRN007G11S-4UX	15	30						
	FRN007, 010P11S-4UX	15,20	30,40	31.0(3.5)					
	FRN010G11S-4UX	20	40						
	FRN015P11S-4UX	30	50						
	FRN015G11S-4UX	30	50	51.3(5.8)	10.6(1.2)	6.2(0.7)		16(1.3)	24 (0.2)
	FRN020P11S-4UX	40	60						
	FRN020G11S-4UX	40	60						
	FRN025P11S-4UX	40	75	119(13.5)					
	FRN025G11S-4UX	40	75						
	FRN030P11S-4UX	50	100						
	FRN030G11S-4UX	50	100	239(27)					
	FRN040G11S/P11S-4UX	75	125						
	FRN050G11S/P11S-4UX	100	125						
	FRN060G11S/P11S-4UX	100	150	425(48)					
	FRN075G11S/P11S-4UX	125	200						
	FRN100P11S-4UX	175	-						
	FRN100G11S-4UX	175	-	119(13.5)					
	FRN125G11S/P11S-4UX	200	-						
	FRN150G11S/P11S-4UX	250	-						
	FRN200P11S-4UX	300	-	239(27)					
	FRN200G11S-4UX	300	-						
	FRN250G11S/P11S-4UX	350	-						
	FRN300P11S-4UX	500	-	425(48)					
FRN300G11S-4UX	500	-							
FRN350G11S/P11S-4UX	500	-							
FRN400G11S/P11S-4UX	600	-	119(13.5)						
FRN450P11S-4UX	700	-							
FRN450G11S-4UX	700	-							
FRN500G11S/P11S-4UX	800	-	239(27)						
FRN600G11S/P11S-4UX	1,000	-							
FRN700P11S-4UX	1,000	-							
FRN800P11S-4UX	1,200	-	425(48)						
FRN800G11S-4UX	1,200	-							
FRN800P11S-4UX	1,200	-							

Note: The type of wire is 70°C(149°F) 600V Grade heat-resistant polyvinyl chloride insulated wires (PVC).

The above-mentioned wire size are the recommended size under the condition of the ambient temperature 50°C(122°F) or lower.

CAUTION on Magnetic contactor selection (without DCR)

[without DCR]

The magnetic contactor should be selected from "Magnetic contactor models" shown in table 2-3-4 to prevent the welding the magnetic contactor when using the auxiliary power input (R0, T0) and the time between the magnetic contactor of the main circuit (L1/R, L2/S, L3/T) is OFF and re-turning on is "T off main circuit re-turning on time" or the less shown in table 2-3-4.

[with DCR or other conditions]

When the inverter which is NOT described in the table 2-3-4 or using with DCR (power-factor correcting DC reactor), the magnetic contactor is selected from "2-3-5 Applicable equipment and wire size for main circuit" in chapter 2.

Table 2-3-4 Re-turning on time and recommended magnetic contactor models

Voltage	G11S	P11S	*1 T off Re-turning on time [s] (the time from power OFF to re-turning on)	*2 Magnetic contactor models (without DCR)
3-Phase 230V series	FRN002G11S-2UX	-	54	SC-N1
	FRN003G11S-2UX		76	
	FRN005G11S-2UX		108	SC-N2
	FRN007G11S-2UX	FRN007P11S-2UX	77	SC-N2S
	FRN010G11S-2UX	FRN010P11S-2UX	112	
	FRN015G11S-2UX	FRN015P11S-2UX	77	SC-N3
3-Phase 460V series	FRN002G11S-4UX	-	27	SC-5-1
	FRN003G11S-4UX		38	SC-N1
	FRN005G11S-4UX		54	
	FRN007G11S-4UX	FRN007P11S-4UX	43	SC-N2
	FRN010G11S-4UX	FRN010P11S-4UX	57	
	FRN015G11S-4UX	FRN015P11S-4UX	77	SC-N2S
	FRN020G11S-4UX	FRN020P11S-4UX	112	
	FRN025G11S-4UX	FRN025P11S-4UX	134	
	FRN030G11S-4UX	FRN030P11S-4UX	154	SC-N3

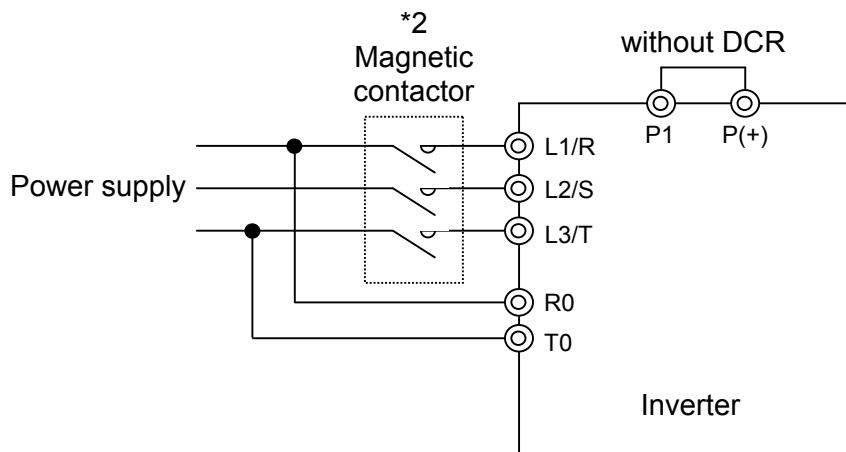

Auxiliary power input

supplied

Magnetic contactor

ON

OFF

ON

*1 T off

3. Operation

3-1 Inspection and Preparation before Operation

Check the following before operation:

- ① Check that the connection is correct.
In particular, check that the power supply is not connected to any of the U, V, and W output terminals and that the ground terminal is securely grounded.
- ② Check for short-circuits and ground faults between the terminals and live sections.
- ③ Check for loose terminals, connectors, or screws.
- ④ Check that the motor is separated from mechanical equipment.
- ⑤ Turn off switches before turning power to ensure that the inverter will not start or operate abnormally at power-on.
- ⑥ Check the following after power-on:
 - a. Check that no alarm message is displayed on the keypad panel (see Figure 3-1-2).
 - b. Check that the fan inside the inverter is rotating. (For inverters with 2HP or more)

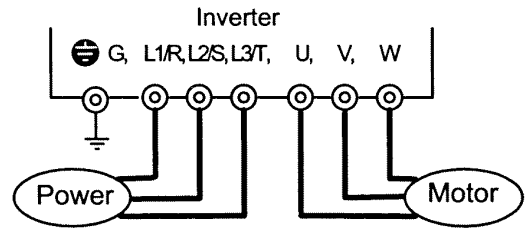



Fig. 3-1-1 Inverter connection

 WARNING	Be sure to put on the surface cover before turning on the power (close). Never remove the cover while the power is applied to the inverter. To ensure safety, do not operate switches with wet hands. Electric shock may result
--	---

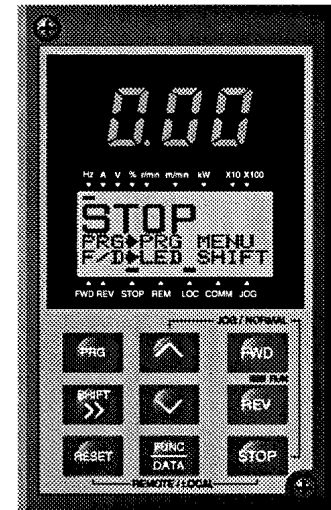

Fig. 3-1-2 Display on keypad panel at power-on

3-2 Operation Method

There are various methods of operation. Select a method of operation according to operating purpose and specifications by referring to Section 4-2, "Operating the Keypad Panel," and Chapter 5, "Explanation of Functions." Table 3-2-1 lists general operation methods

3-3 Trial Run

Upon confirming that inspection results are normal (see Section 3-1), proceed with a trial run. The initial operation mode (set at factory) is using the keypad panel.



- ① Turn power on and confirm that frequency display 0.00Hz is blinking on the LED monitor.
- ② Set the frequency to about 5Hz using  key.
- ③ To start the run, press **FWD** key (for forward rotation) or **REV** key (for reverse rotation). To stop, press **STOP** key.
- ④ Check the following items :
 - a. Is the rotating direction correct?
 - b. Is the rotation smooth? (no buzzing or abnormal vibration)
 - c. Is acceleration and deceleration smooth?

Table 3-2-1 General operation methods

Operation command	Frequency setting	Operation command
Operation using keypad panel	Keys on keypad panel  	FWD REV STOP
Operation using external signal terminals	Freq. Setting POT (VR), analog voltage, analog current	Contact input (switch) Terminals FWD-CM and REV-CM

If no abnormality is detected, increase the frequency and check the above items again. If the results of the trial run are normal, start a formal run.

- Notes:**
- If an error is detected in the inverter or motor, immediately stop the operation and attempt to determine the cause of error referring to Chapter 7, "Troubleshooting."
 - As voltage is still applied to the main circuit terminals (L1/R, L2/S, L3/T) and auxiliary control-power terminals (R0, T0) even when the output from the inverter is terminated, do not touch the terminals. The smoothing capacitor in the inverter is being charged after the power is turned off and it is not discharged immediately. Before touching an electric circuit, confirm that the charge lamp is off or a multimeter is indicating a low voltage at the terminals.

4. Keypad Panel

The keypad panel has various functions for specifying operations such as keypad operation (frequency setting, run/stop command), confirming and changing function data, confirming status, and copying. Review the use of each function before commencing running.

The keypad panel can also be removed or inserted during running. However, if the keypad panel is removed during a keypad panel operation (e.g., run/stop, frequency setting), the inverter stops and outputs an alarm.

4-1 Appearance of Keypad Panel



LED monitor:

Four-digit 7-segment display

Used to display various items of monitored data such as setting frequency, output frequency and alarm code.

Auxiliary information indication for LED monitor:

Selected units or multiple of the monitored data (on the LED monitor) are displayed on the top line of the LCD monitor. The ■ symbol indicates selected units or multiple number. The symbol ▲ indicates there is an upper screen not currently displayed.

LCD monitor:

Used to display such various items of information as operation status and function data. An operation guide message, which can be scrolled, is displayed at the bottom of the LCD monitor.

This LCD monitor has a backlight feature which turns on when the control power is applied or any keypad key is pressed, and stays on approximately 5 minutes after the last key stroke.

Indication on LCD monitor:

Displays one of the following operation status:

FWD: Forward operation REV: Reverse operation
STOP: Stop

Displays the selected operation mode:

REM: Terminal block LOC: Keypad panel
COMM: Communication terminal
JOG: Jogging mode

The symbol ▼ indicates there is a lower screen not currently displayed.

RUN LED :

Indicates that an operation command was input by pressing the **FWD** or **REV** key.

Control keys (valid during keypad panel operation):

Used for inverter run and stop

- FWD** : Forward operation command
- REV** : Reverse operation command
- STOP** : Stop command

Operation keys:

Used for screen switching, data change, frequency setting, etc.

Table 4-1-1 Functions of operation keys

Operation key	Main function
PRG	Used to switch the current screen to the menu screen or switch to the initial screen in the operation/trip mode.
FUNC DATA	Used to switch the LED monitor or to determine the entered frequency, function code, or data.
▲ , ▼	Used to change data, move the cursor up or down, or scroll the screen
SHIFT >>	Used to move the cursor horizontally at data change. When this key is pressed with the up or down key, the cursor moves to the next function block.
RESET	Used to cancel current input data and switch the displayed screen. If an alarm occurs, this key is used to reset the trip status (valid only when the alarm mode initial screen is displayed).
STOP + ▲	Used to switch normal operation mode to jogging operation mode or vice versa. The selected mode is displayed on the LCD monitor.
STOP + RESET	Switches operation mode (from keypad panel operation mode to terminal block operation mode or reverse). When these keys are operated, function F01 data is also switched from 0 to 1 or from 1 to 0. The selected mode is displayed on the LCD indicator.

4-2 Keypad Panel Operation System (LCD screen, Level Structure)

4-2-1 Normal operation

The keypad panel operation system (screen transition, level structure) is structured as follows:

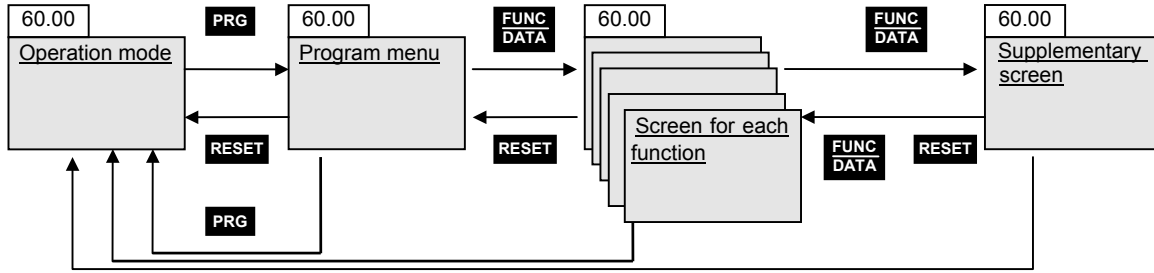

4-2-2 Alarm occurrence

If an alarm is activated, operation is changed from normal keypad panel operation to an alarm mode operation. The alarm mode screen appears and alarm information is displayed.

The program menu, function screens, and supplementary screens remain unchanged as during normal operation, though the switching method from program menu to alarm mode is limited to **PRG**.

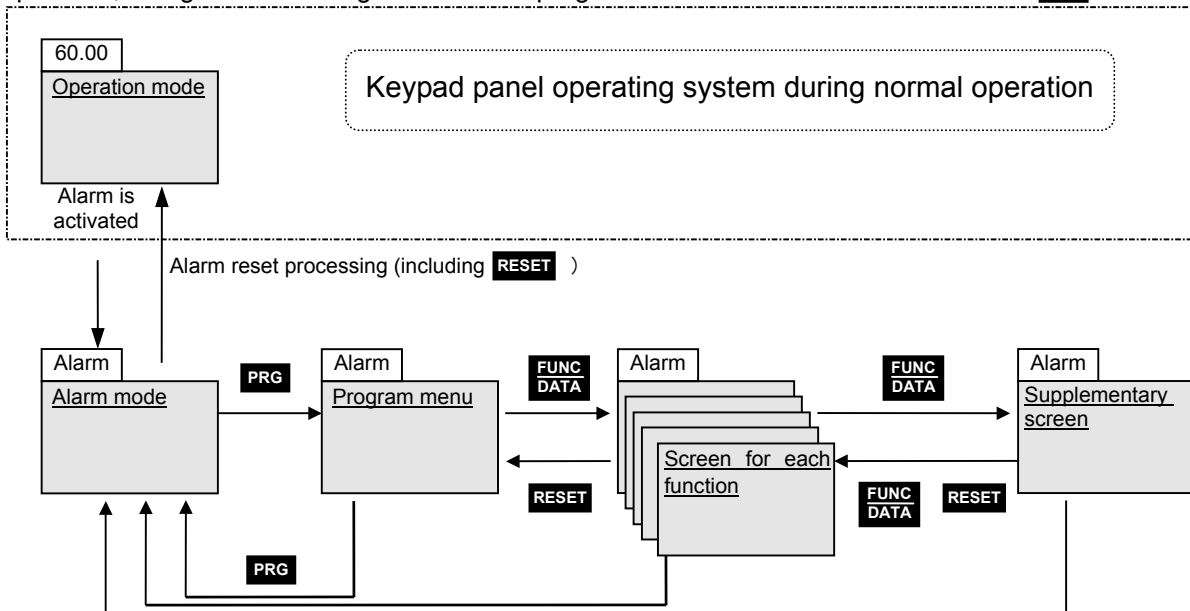

Table 4-2-1 Overview of contents displayed for each level

No.	Level name	Content																														
1	Operating mode	This screen is for normal operation. Frequency setting by keypad panel and the LED monitor switching are possible only when this screen is displayed.																														
2	Program menu	<p>Each function of the keypad panel is displayed in menu form and can be selected. Selecting the desired function from the list and pressing FUNC DATA displays the screen of the selected function. The following functions are available as keypad panel functions (menus).</p> <table border="1"> <thead> <tr> <th>No.</th> <th>Menu name</th> <th>Outline</th> </tr> </thead> <tbody> <tr> <td>1</td> <td>DATA SET</td> <td>The code and name of the function are displayed. Selecting a function displays a data setting screen for checking, or modifying data.</td> </tr> <tr> <td>2</td> <td>DATA CHECK</td> <td>The code and name of the function are displayed. Select a function to display a screen for checking data. Modifying data is possible as described above by going to the data setting screen.</td> </tr> <tr> <td>3</td> <td>OPR MNTR</td> <td>Can check various data on the operating status.</td> </tr> <tr> <td>4</td> <td>I/O CHECK</td> <td>Can check the status of analog and digital input/output for the inverter and options as an I/O checker.</td> </tr> <tr> <td>5</td> <td>MAINTENANC</td> <td>Can check inverter status, life expectancy, communication error status, and ROM version information as maintenance information.</td> </tr> <tr> <td>6</td> <td>LOAD FCTR</td> <td>Can measure maximum and average current and average breaking force in load rate measurement.</td> </tr> <tr> <td>7</td> <td>ALM INF</td> <td>Can check the operating status and input/output status at the latest alarm occurrence.</td> </tr> <tr> <td>8</td> <td>ALM CAUSE</td> <td>Can check the latest alarm or simultaneously occurred alarms and alarm history. Selecting the alarm and pressing FUNC DATA, displays the contents of alarm as troubleshooting.</td> </tr> <tr> <td>9</td> <td>DATA COPY</td> <td>Places the function of one inverter in memory for copying to another inverter.</td> </tr> </tbody> </table>	No.	Menu name	Outline	1	DATA SET	The code and name of the function are displayed. Selecting a function displays a data setting screen for checking, or modifying data.	2	DATA CHECK	The code and name of the function are displayed. Select a function to display a screen for checking data. Modifying data is possible as described above by going to the data setting screen.	3	OPR MNTR	Can check various data on the operating status.	4	I/O CHECK	Can check the status of analog and digital input/output for the inverter and options as an I/O checker.	5	MAINTENANC	Can check inverter status, life expectancy, communication error status, and ROM version information as maintenance information.	6	LOAD FCTR	Can measure maximum and average current and average breaking force in load rate measurement.	7	ALM INF	Can check the operating status and input/output status at the latest alarm occurrence.	8	ALM CAUSE	Can check the latest alarm or simultaneously occurred alarms and alarm history. Selecting the alarm and pressing FUNC DATA , displays the contents of alarm as troubleshooting.	9	DATA COPY	Places the function of one inverter in memory for copying to another inverter.
No.	Menu name	Outline																														
1	DATA SET	The code and name of the function are displayed. Selecting a function displays a data setting screen for checking, or modifying data.																														
2	DATA CHECK	The code and name of the function are displayed. Select a function to display a screen for checking data. Modifying data is possible as described above by going to the data setting screen.																														
3	OPR MNTR	Can check various data on the operating status.																														
4	I/O CHECK	Can check the status of analog and digital input/output for the inverter and options as an I/O checker.																														
5	MAINTENANC	Can check inverter status, life expectancy, communication error status, and ROM version information as maintenance information.																														
6	LOAD FCTR	Can measure maximum and average current and average breaking force in load rate measurement.																														
7	ALM INF	Can check the operating status and input/output status at the latest alarm occurrence.																														
8	ALM CAUSE	Can check the latest alarm or simultaneously occurred alarms and alarm history. Selecting the alarm and pressing FUNC DATA , displays the contents of alarm as troubleshooting.																														
9	DATA COPY	Places the function of one inverter in memory for copying to another inverter.																														
3	Screen for each function	The function screen selected on the program menu appears, hence completing the function.																														
4	Supplementary screen	Functions not completed (e.g., modifying function data, displaying alarm factors) on individual function screens are displayed on the supplementary screen.																														

4-3 Operating Keypad Panel

4-3-1 Operation Mode

The screen for normal inverter operation includes a screen for displaying inverter operating status and an operation guide and a screen for graphically displaying the operating status in the form of a bar graph. Switching between both screens is possible using the E45 function.

1) Operation guide (E45=0)

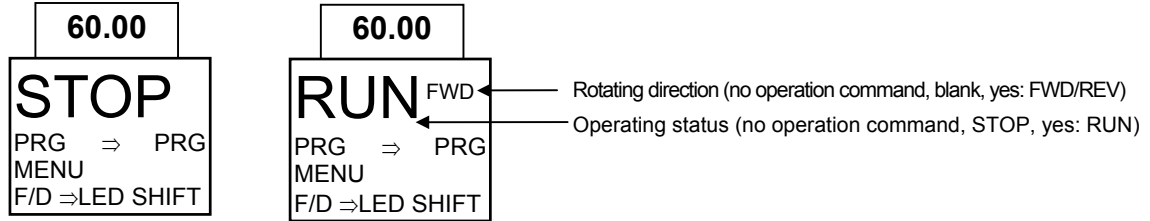

2) Bar graph (E45=1)

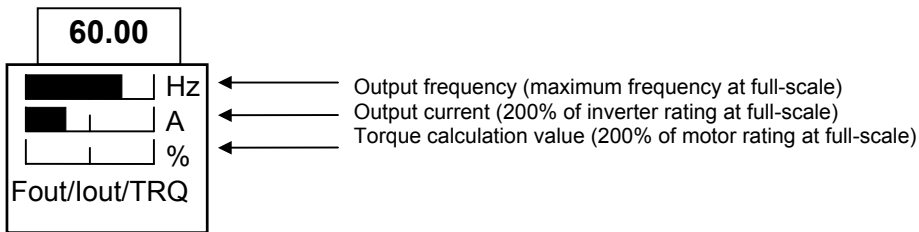

4-3-2 Setting digital frequency

On the operation mode screen, press **▲** or **▼** to display the set frequency on the LED. Data is initially incremented and decremented in the smallest possible unit. Holding down **▲** or **▼** increases or decreases the speed of increment or decrement. The digit to change data can be selected using **SHIFT >>** and then data can be set directly. To save the frequency settings, press **FUNC DATA**. Press **RESET** and **PRG** to return to the operation mode.

If keypad panel settings are not selected, the present frequency setting mode appears on the LCD. When selecting the PID function, PID command can be set with a process value. (Refer to technical documentation for details).

1) Digital (keypad panel) settings (F01=0 or C30=0)

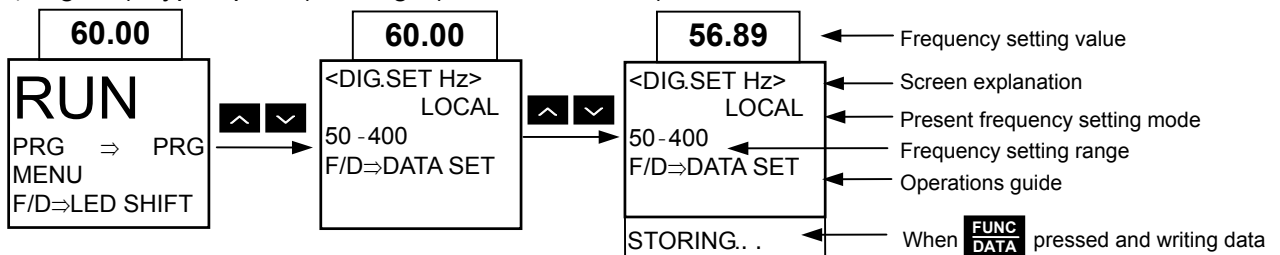

2) Other than digital setting

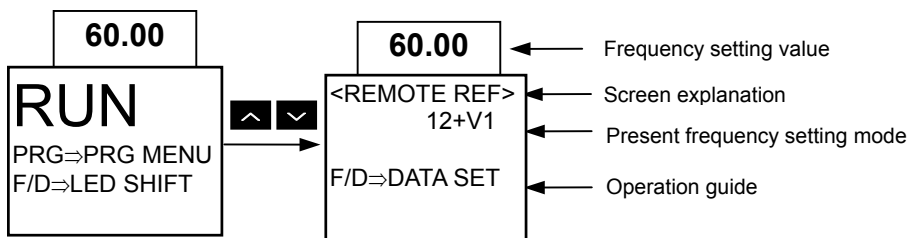

4-3-3 Switching the LED monitor

On the normal operation, press **FUNC DATA** to switch to LED monitor display.

When power is turned on, the monitor contents set by the function (E43) are displayed on the LED.

E43	When stopping		When running (E44 = 0,1)	Unit	Remarks
	(E44 = 0)	(E44 = 1)			
0	Setting frequency	Output frequency 1 (before slip compensation)	Setting frequency	Hz	
1	Setting frequency	Output frequency 2 (after slip compensation)			
2	Setting frequency				
3	Output current	Output current		A	
4	Output voltage (specified value)	Output voltage (specified value)		V	
5	Synchronous speed setting value	Synchronous speed		r/min.	For 4 digits or more, the last digits are cut, with x10, x100 marked on the indicator.
6	Line speed setting value	Line speed		m/min.	
7	Load rotation speed setting value	Load rotation speed		r/min.	
8	Torque calculation value	Torque calculation value		%	± indication
9	Power consumption	Power consumption		kW	
10	PID setting value	PID setting value		–	Displayed only when PID is effective in PID operation selection.
11	PID remote setting value	PID remote setting value		–	
12	PID feedback value	PID feedback value		–	

4-3-4 Menu screen

The “Program menu” screen is shown below. Only four items can be displayed simultaneously. Move the cursor with **▲** or **▼** to select an item, then press **FUNC DATA** to display the next screen.

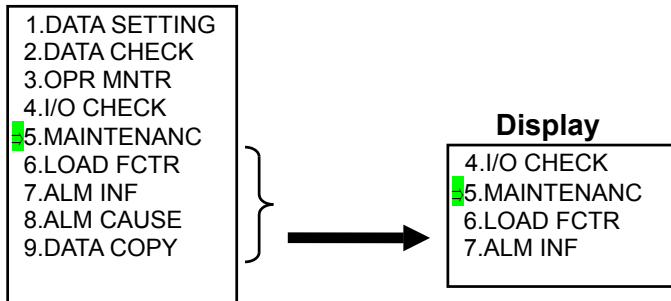

4-3-5 Setting function data

On the “program menu” screen, select “**1. Data Setting**” then the “Function Select” screen appears with function codes and names on it. Select the desired function.

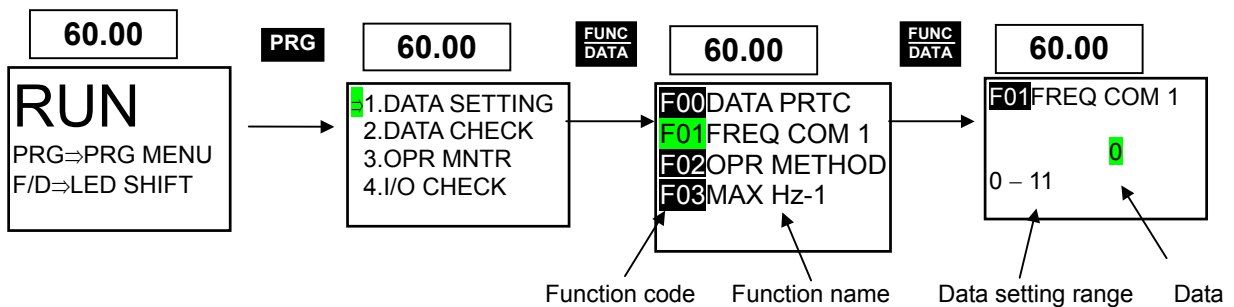

The function code consists of alphanumeric characters. Unique alphabetical letters are assigned for each function group.

Table 4-3-1

Function code	Function	Remarks
F00 - F42	Fundamental Functions	
E01 - E47	Extension Terminal Functions	
C01 - C33	Control Functions of Frequency	
P01 - P09	Motor Parameters	
H03 - H39	High Performance Functions	
A01 - A18	Alternative Motor Parameters	
U01 - U61	User Functions	
o01 - o55	Optional Functions	Can be selected only with an option connected

To scroll "Function Select" screen rapidly, use **>>** + **▲** or **>>** + **▼** to move the screen in a unit grouped by alphabet.

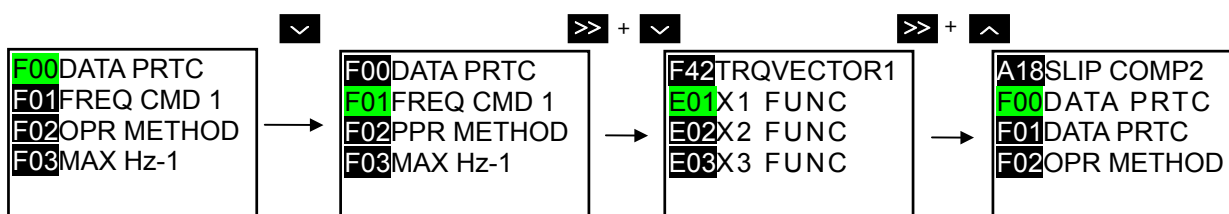

Select the desired function and press **FUNC DATA** to switch to the "data setting" screen.

On the "data setting" screen, the data values on the LCD can be increased or decreased in the smallest possible unit by pressing **▲** or **▼**. Holding down **▲** or **▼** expands the rate of change, thereby enabling values to be modified more rapidly. Otherwise, select the digit to be modified using **>>**, then set data directly. When data is modified, the value before modification will be displayed at the same time for reference purpose. To save the data, press **FUNC DATA**. Pressing **RESET** cancels the changes made and returns to the "Function Select" screen. The modified data will be effective in inverter operation after the data is saved by **FUNC DATA**. The inverter operation does not change only if data is modified. When data setting is disabled in the case of "Data protected" or "Data setting invalid during inverter running," make necessary changes. Data cannot be modified for the following reasons :

Table 4-3-2

Display	Reason for no modification	Release method
LINK ACTIVE	Currently writing from RS-485/link option to Function is being made.	Send a cancel command of function writing from RS-485. Stops a "Write" operation from the link.
NO SIGNAL(WE)	The edit enabling command function is selected using a general-purpose input terminal.	Among functions E01 to E09, turn the terminal of data 19 (edit enabling command selection) ON.
DATA PRTCTD	Data protection is selected for function F00.	Change function F00 to 0.
INV RUNNING	An attempt is made to change a function that cannot be changed during inverter operation.	Stop inverter operation.
FWD/REV ON	An attempt is made to change a function that cannot be changed with the FWD/REV command on.	Turn FWD/REV command off.

4-3-6 Checking function data

On the "Program menu" screen, select **"2. DATA CHECK"**. The "Function Select" screen then appears with function codes and names.

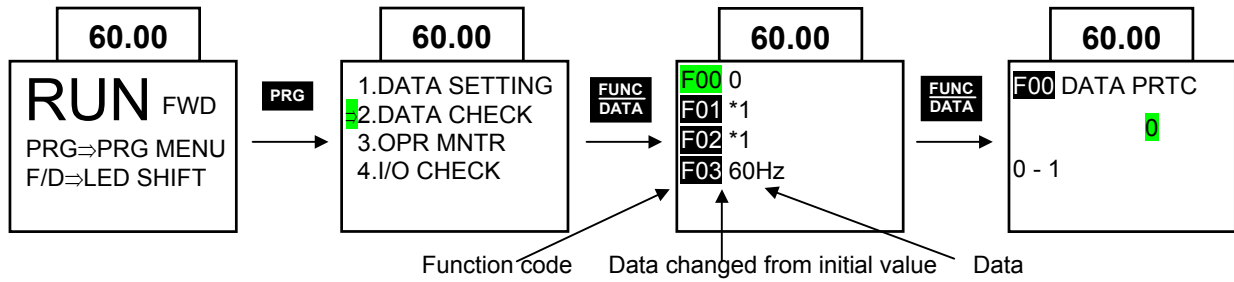

Select the desired function and press **FUNC DATA** to check the function data. By pressing **FUNC DATA**, the screen switches to the "Data setting" screen, to modify data.

4-3-7 Monitoring operating status

On the "Program menu" screen, select **"3. OPR MNTR"** to display the present operating status of inverter. Use **▲** and **▼** to switch between the four operation monitor screens.

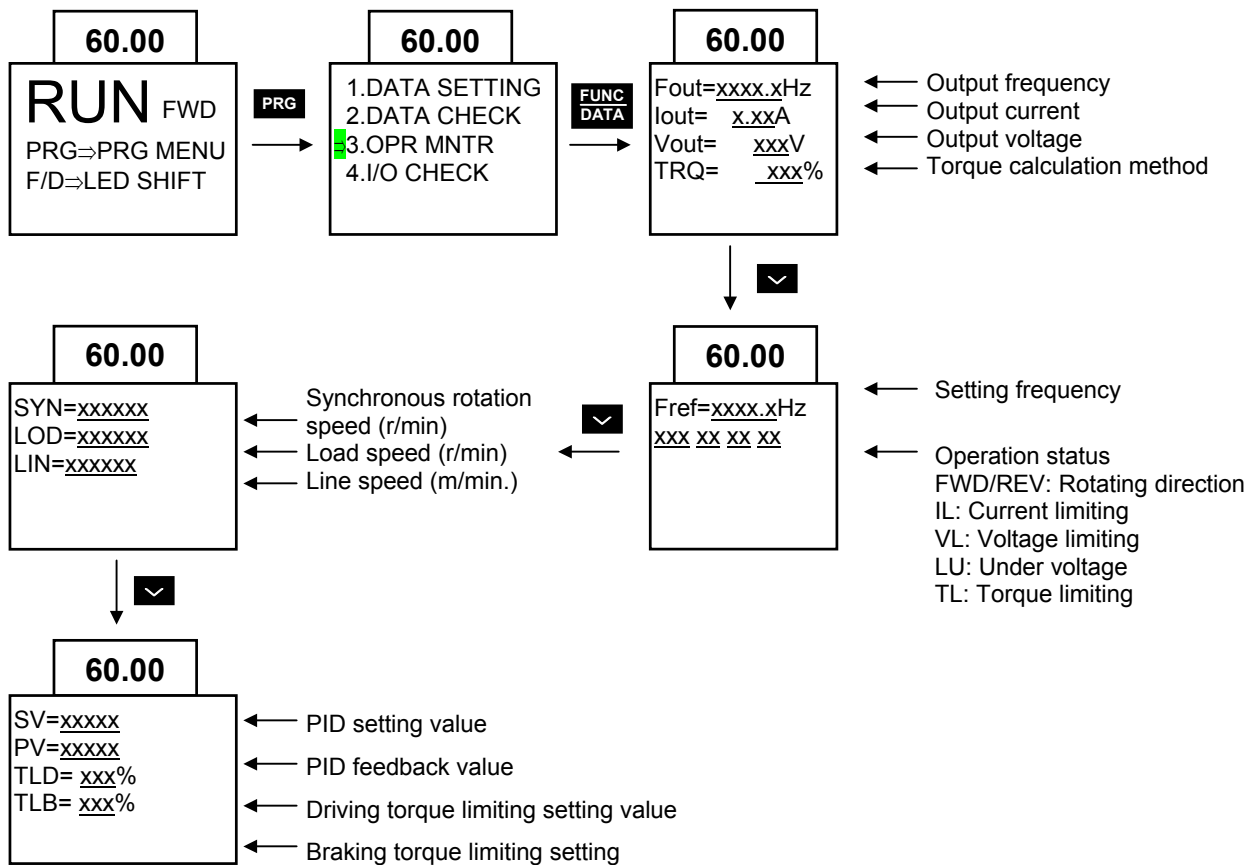

4-3-8 I/O check

On the "Program menu" screen, select "4. I/O Check" to display analog and digital input/output signal status for the inverter and options. Use **▲** and **▼** to switch between the eight screens of data.

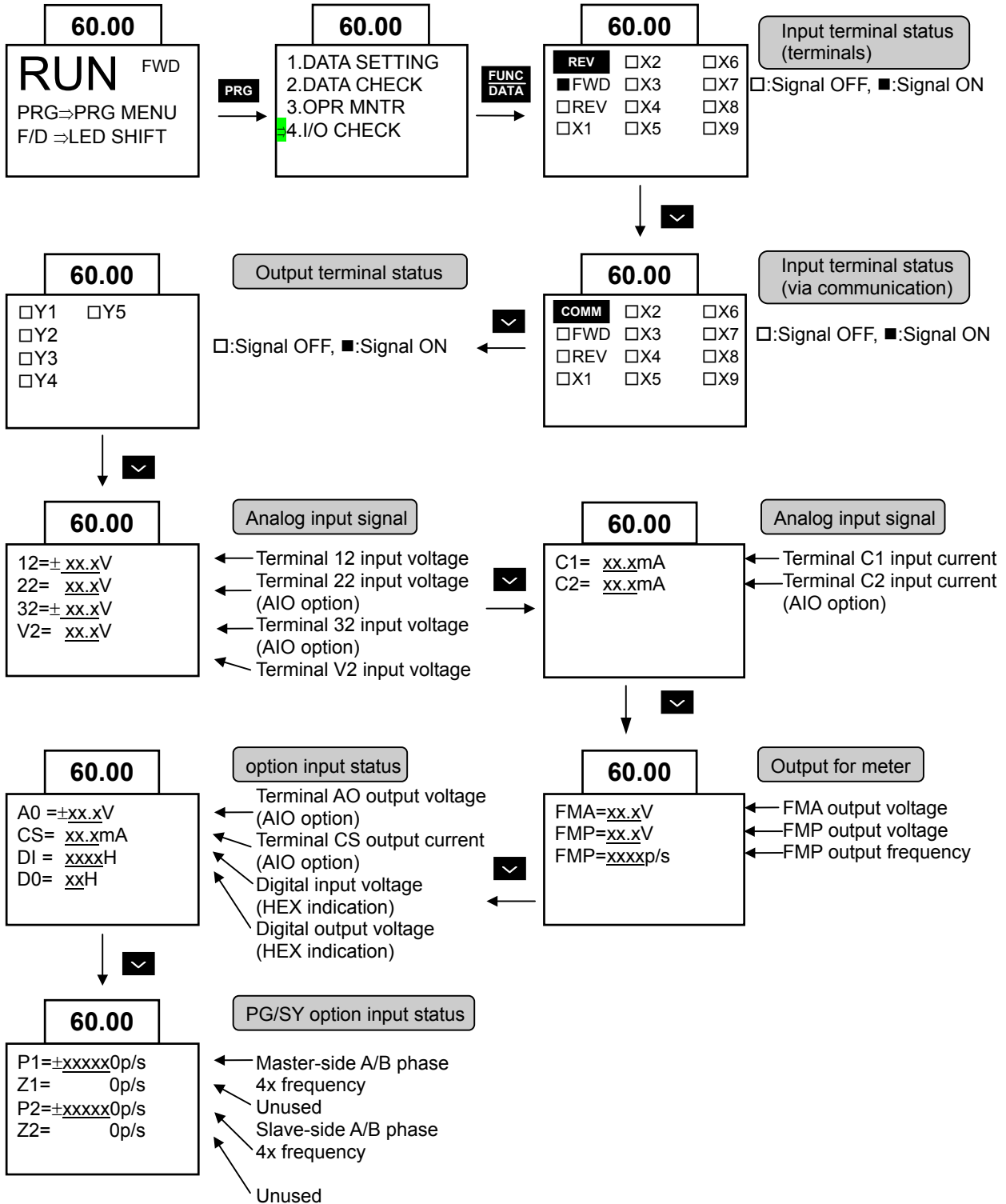

4-3-9 Maintenance information

On the "Program menu" screen, select "5. Maintenance" to display information necessary for maintenance and inspection. Use **▲** and **▼** to switch between the five screens of data.

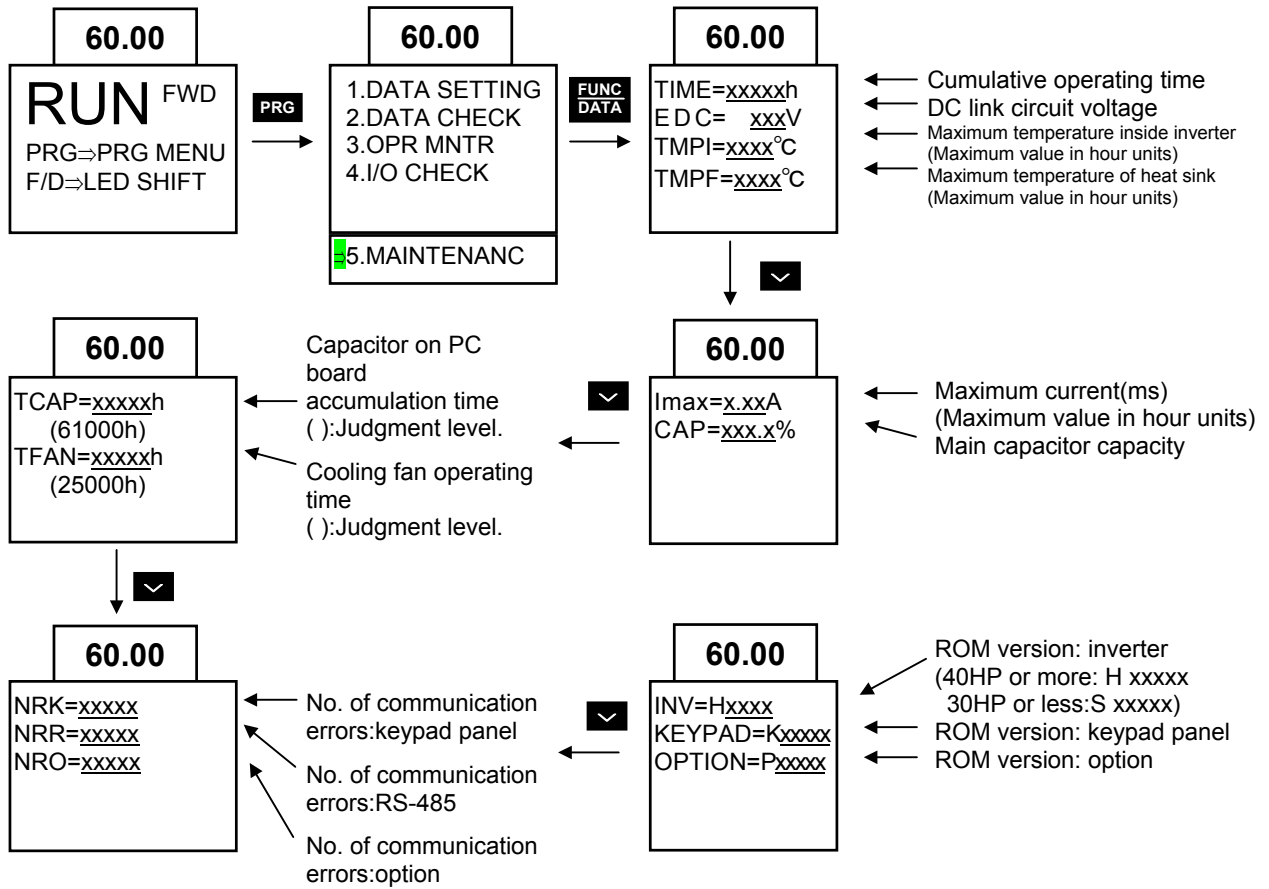

4-3-10 Load rate measurement

On the "Program menu" screen, select "6. Load Rate Measurement". On the "Load rate measurement" screen, the maximum current, average current, and average breaking power during the set measuring time are measured and displayed.

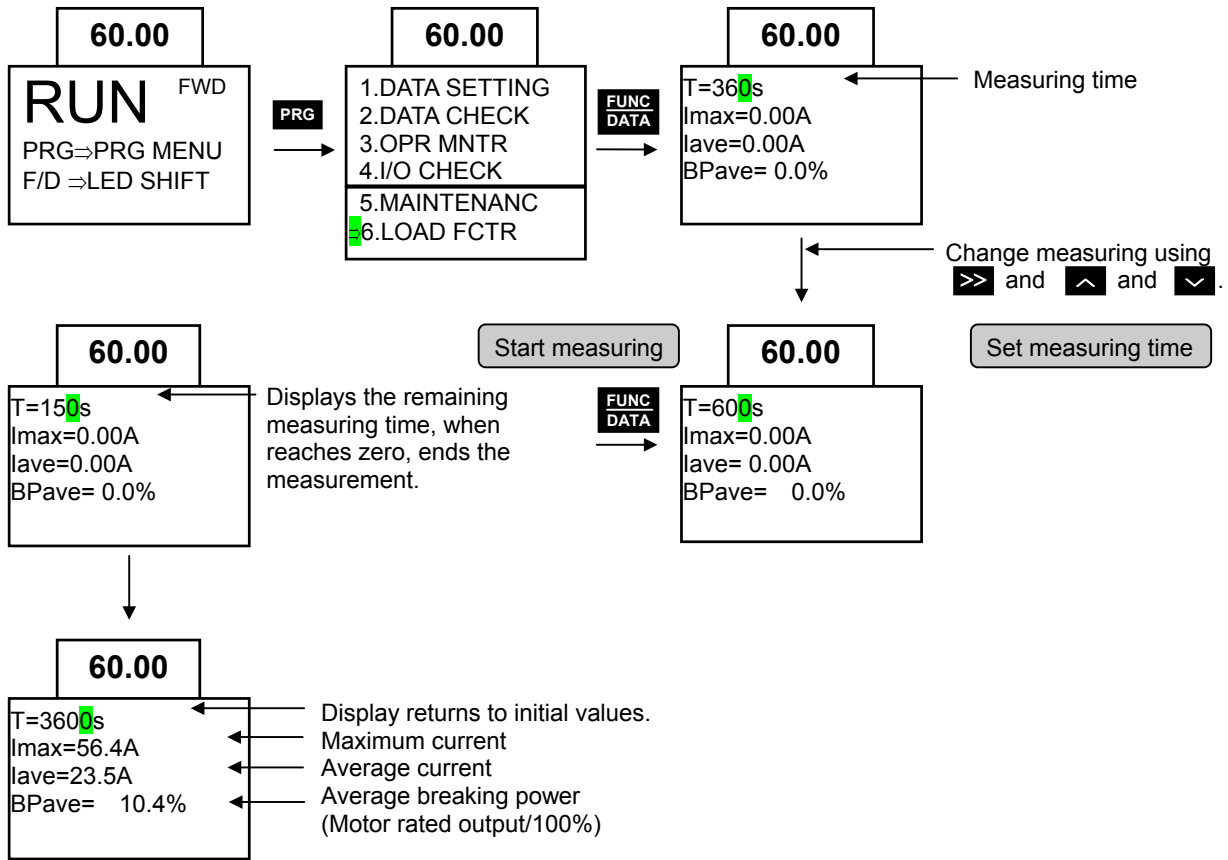

4-3-11 Alarm information

On the "Program menu" screen, select "7. Alarm Information". Various operating data when the latest alarm occurred is displayed. Use and to switch between the nine screens of alarm information data.

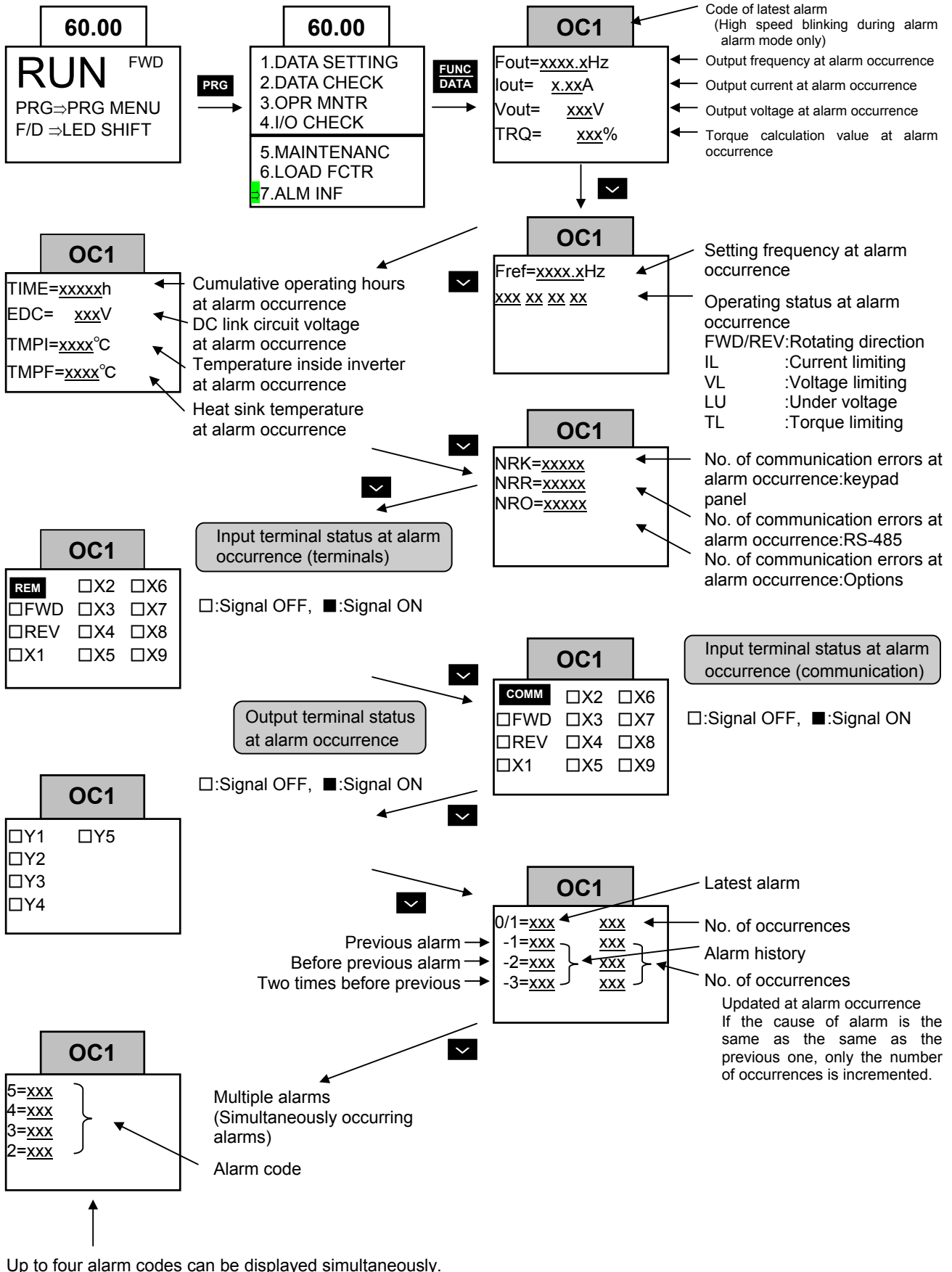

Up to four alarm codes can be displayed simultaneously.

4-3-12 Alarm history and factors

On the "Program menu" screen, select "8.Alarm Factors" to display the alarm history.

Press **FUNC DATA** to display troubleshooting information for the alarm selected.

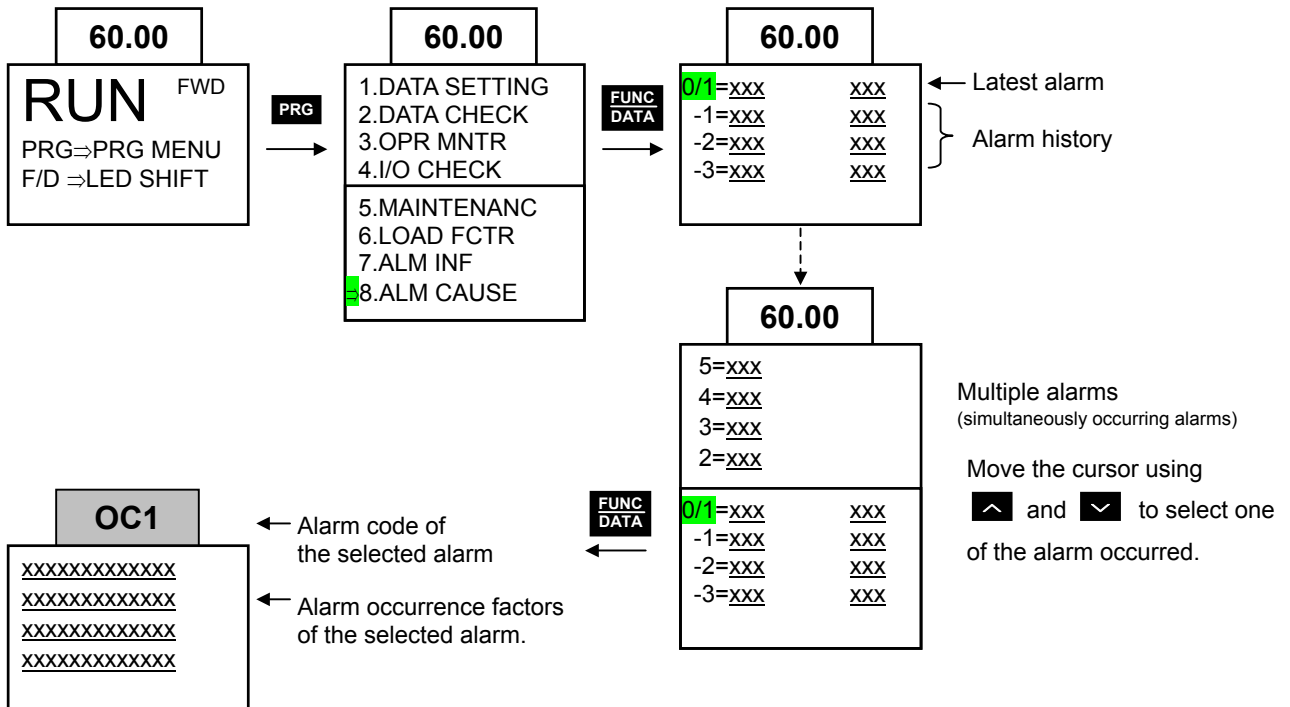

4-3-13 Data copy

On the "Program menu" screen, select **"9. Data Copy"** to display the data copy read screen. A copy operation is then performed in the following order; reading inverter function data, removing the keypad panel, attaching the keypad panel to another inverter, and writing the data to the inverter.

The "verify" feature also makes it possible to compare and check differences in the data stored in the keypad panel and the data stored in the inverter.

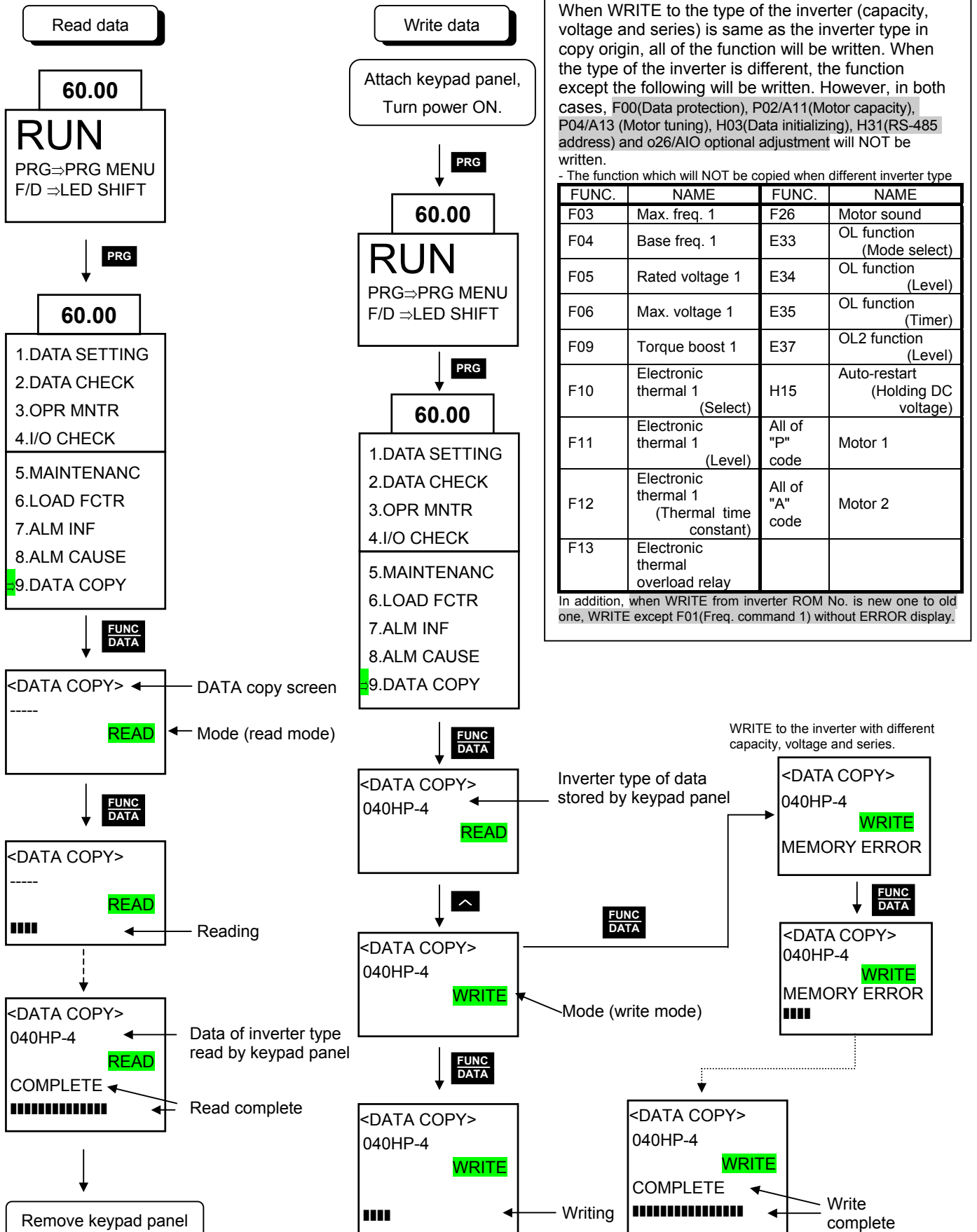

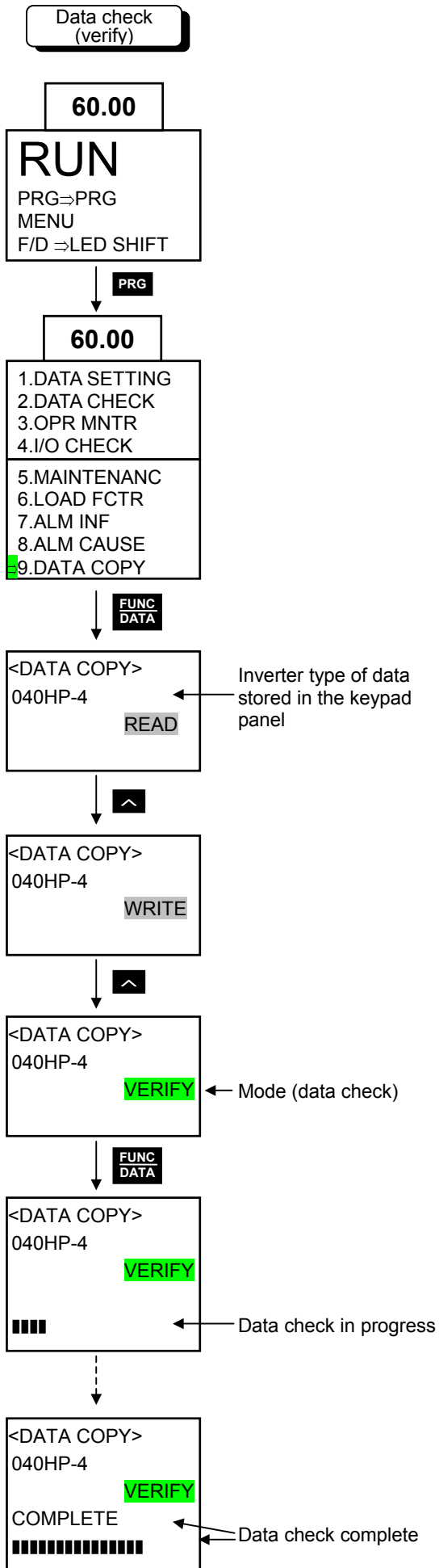

Error processing

1) Change disabled during operation

If a write operation is attempted during an inverter operation, or vice versa, the error message below will appear.

After stopping the inverter and pressing **RESET**, retry the write operation.

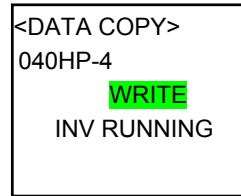

2) Memory error

If a write operation is attempted while data has not been saved (i.e., no data) in the keypad panel data memory during the read mode, the following error message will appear:

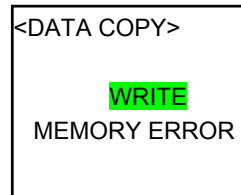

3) Verify error

During a data check (verify) operation, if data stored in the keypad panel differs from data stored in the inverter, the following error message is displayed to indicate the function No. The data check is suspended.

To continue the data check and check for other mismatching data, press **FUNC DATA**. To stop the data check and switch to another operation, press **RESET**.

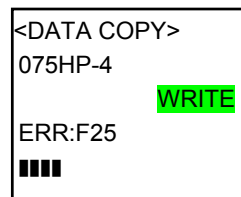

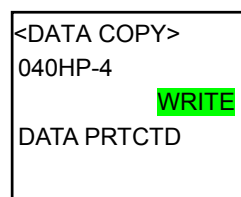

4) Data protection

When WRITE to the inverter which is protected by "Data protection" function, the following error message will appear. After released the protection, write operation is attempted.





4-3-14 Alarm mode

If an alarm occurs, the "Alarm screen" indicating the alarm contents is displayed. Use  and  to display alarm history and multiple alarms (if more than two alarms occur simultaneously).

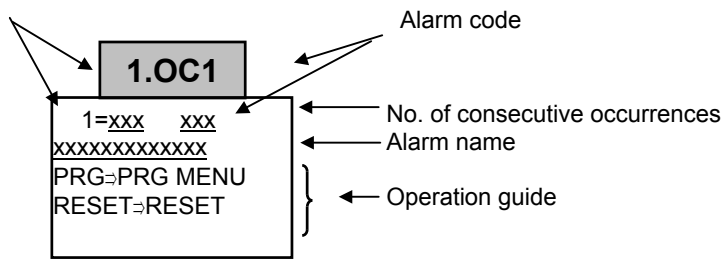
Alarm detection order



Alarm detection order

Operation method	LED display	LCD display	Description
 	5.	5	No. 5 alarm
	4.	4	No. 4 alarm
	3.	3	No. 3 alarm
	2.	2	No. 2 alarm
	1.	1	No. 1 alarm (more than two alarms occurred)
	Blank	0	Latest alarm (only one alarm occurred/alarm released)
	Blank	-1	Previous alarm history
	Blank	-2	Alarm history before previous alarm
	Blank	-3	Alarm history two times before previous alarm

Alarm code: See Table 6-1-1

5. Function select

5-1 Function select list

F:Fundamental Functions

Func No.	NAME	LCD Display	Setting range	Unit	Min. Unit	Factory setting		Change during op	User Set value	Remark
						-30HP	40HP-			
F00	Data protection	F00 DATA PRCT	0, 1	-	-	0		NA		
F01	Frequency command 1	F01 FREQ CMD 1	0 to 11	-	-	0		NA		
F02	Operation method	F02 OPR METHOD	0 to 4	-	-	0		NA		
F03	Maximum frequency 1	F03 MAX Hz-1	G11S: 50 to 400Hz P11S: 50 to 120Hz	Hz	1	60		NA		
F04	Base frequency 1	F04 BASE Hz-1	G11S: 25 to 400Hz P11S: 25 to 120Hz	Hz	1	60		NA		
F05	Rated voltage 1 (at Base frequency 1)	F05 RATED V-1	0V: (Output voltage proportional to source voltage) 80 to 240V: (230V class) 320 to 480V: (460V class)	V	1	230:(230V class) 460:(460V class)		NA		
F06	Maximum voltage 1 (at Maximum frequency 1)	F06 MAX V-1	80 to 240V: (230V class) 320 to 480V: (460V class)	V	1	230:(230V class) 460:(460V class)		NA		
F07	Acceleration time 1	F07 ACC TIME1	0.01 to 3600s	s	0.01	6.0	20.0	A		
F08	Deceleration time 1	F08 DEC TIME1								
F09	Torque boost 1	F09 TRQ BOOST1	0.0, 0.1 to 20.0	-	0.1	G11S:2.0 P11S:2.0		A		
F10	Electronic (Select)	F10 ELCTRN OL1	0, 1, 2	-	-	1		A		
F11	thermal 1 (Level)	F11 OL LEVEL1	INV rated current 20 to 135%	A	0.01	Motor rated current		A		
F12	(Thermal time constant)	F12 TIME CNST1	0.5 to 75.0 min	min	0.1	5.0	10.0	A		
F13	Electronic thermal overload relay (for braking resistor)	F13 DBR OL	G11 : [Up to 10[HP]] : 0, 1, 2 : [15[HP] and above] : 0 P11 : [Up to 15[HP]] : 0, 2 : [20[HP] and above] : 0	-	-	1 0 0		A A A		
F14	Restart mode after momentary power failure	F14 RESTART	0 to 5	-	-	0		NA		
F15	Frequency limiter (High)	F15 H LIMITER	G11S: 0 to 400Hz	Hz	1	70		A		
F16	(Low)	F16 L LIMITER	P11S: 0 to 120Hz			0		A		
F17	Gain (for freq. set signal)	F17 FREQ GAIN	0.0 to 200.0%	%	0.1	100.0		A		
F18	Bias frequency	F18 FREQ BIAS	G11S: -400.0 to +400.0Hz P11S: -120.0 to +120.0Hz	Hz	0.1	0.0		A		
F20	DC brake (Starting freq.)	F20 DC BRK Hz	0.0 to 60.0Hz	Hz	0.1	0.0		A		
F21	(Braking level)	F21 DC BRK LVL	G11S: 0 to 100% P11S: 0 to 80%	%	1	0		A		
F22	(Braking time)	F22 DC BRK t	0.0s(Inactive) 0.1 to 30.0s	s	0.1	0.0		A		
F23	Starting frequency (Freq.)	F23 START Hz	0.1 to 60.0Hz	Hz	0.1	0.5		NA		
F24	(Holding time)	F24 HOLDING t	0.0 to 10.0s	s	0.1	0.0		NA		
F25	Stop frequency	F25 STOP Hz	0.1 to 60.0Hz	Hz	0.1	0.2		NA		
F26	Motor sound (Carrier freq.)	F26 MTR SOUND	0.75 to 15kHz	kHz	1	2		A		
F27	(Sound tone)	F27 SOUND TONE	0 to 3	-	-	0		A		
F30	FMA (Voltage adjust)	F30 FMA V-ADJ	0 to 200%	%	1	100		A		
F31	(Function)	F31 FMA FUNC	0 to 11	-	-	0		A		
F33	FMP (Pulse rate)	F33 FMP PULSES	300 to 6000p/s (full scale)	p/s	1	1440		A		
F34	(Voltage adjust)	F34 FMP V-ADJ	0%, 1 to 200%	%	1	0		A		
F35	(Function)	F35 FMP FUNC	0 to 10	-	-	0		A		
F36	30RY operation mode	F36 30RY MODE	0, 1	-	-	0		NA		
F40	Torque limiter 1 (Driving)	F40 DRV TRQ 1	G11S: 20 to 200%, 999 P11S: 20 to 150%, 999	%	1	999		A		
F41	(Braking)	F41 BRK TRQ 1	G11S: 0%, 20 to 200%, 999 P11S: 0%, 20 to 150%, 999			999		A		
F42	Torque vector control 1	F42 TRQVECTOR1	0, 1	-	-	0		NA		

E:Extension Terminal Functions

Func No.	NAME	LCD Display	Setting range	Unit	Min. Unit	Factory setting		Change during op	User Set value	Remark
						-30HP	40HP-			
E01	X1 terminal function	E01 X1 FUNC	0 to 35	-	-	0		NA		
E02	X2 terminal function	E02 X2 FUNC				1		NA		
E03	X3 terminal function	E03 X3 FUNC				2		NA		
E04	X4 terminal function	E04 X4 FUNC				3		NA		
E05	X5 terminal function	E05 X5 FUNC				4		NA		
E06	X6 terminal function	E06 X6 FUNC				5		NA		
E07	X7 terminal function	E07 X7 FUNC				6		NA		
E08	X8 terminal function	E08 X8 FUNC				7		NA		
E09	X9 terminal function	E09 X9 FUNC				8		NA		
E10	Acceleration time 2	E10 ACC TIME2	0.01 to 3600s	s	0.01	6.00	20.00	A		
E11	Deceleration time 2	E11 DEC TIME2				6.00	20.00	A		
E12	Acceleration time 3	E12 ACC TIME3				6.00	20.00	A		
E13	Deceleration time 3	E13 DEC TIME3				6.00	20.00	A		
E14	Acceleration time 4	E14 ACC TIME4				6.00	20.00	A		
E15	Deceleration time 4	E15 DEC TIME4				6.00	20.00	A		
E16	Torque limiter 2 (Driving)	E16 DRV TRQ 2	G11S: 20 to 200%, 999 P11S: 20 to 150%, 999	%	1	999		A		
E17	(Braking)	E17 BRK TRQ 2	G11S: 0%, 20 to 200%, 999 G11S: 0%, 20 to 150%, 999	%	1	999		A		
E20	Y1 terminal function	E20 Y1 FUNC	0 to 37	-	-	0		NA		
E21	Y2 terminal function	E21 Y2 FUNC				1		NA		
E22	Y3 terminal function	E22 Y3 FUNC				2		NA		
E23	Y4 terminal function	E23 Y4 FUNC				7		NA		
E24	Y5A, Y5C terminal func.	E24 Y5 FUNC				10		NA		
E25	Y5 RY operation mode	E25 Y5RY MODE	0,1	-	1	0		NA		
E30	FAR function (Hysteresis)	E30 FAR HYSTR	0.0 to 10.0Hz	Hz	0.1	2.5		A		
E31	FDT function (Level)	E31 FDT1 LEVEL	G11S: 0 to 400Hz P11S: 0 to 120Hz	Hz	1	60		A		
E32	signal (Hysteresis)	E32 FDT1 HYSTR	0.0 to 30.0Hz	Hz	0.1	1.0		A		
E33	OL1 function(Mode select)	E33 OL1 WARNING	0: Thermal calculation 1: Output current	-	-	0		A		
E34	signal (Level)	E34 OL1 LEVEL	G11S: 5 to 200% P11S: 5 to 150%	A	0.01	Motor rated current		A		
E35	(Timer)	E35 OL1 TIMER	0.0 to 60.0s	s	0.1	10.0		A		
E36	FDT2 function (Level)	E36 FDT2 LEVEL	G11S: 0 to 400Hz P11S: 0 to 120Hz	Hz	1	60		A		
E37	OL2 function (Level)	E37 OL2 LEVEL	G11S: 5 to 200% G11S: 5 to 150%	A	0.01	Motor rated current		A		
E40	Display coefficient A	E40 COEF A	-999.00 to 999.00	-	0.01	0.01		A		
E41	Display coefficient B	E41 COEF B	-999.00 to 999.00	-	0.01	0.00		A		
E42	LED Display filter	E42 DISPLAY FL	0.0 to 5.0s	s	0.1	0.5		A		
E43	LED Monitor (Function)	E43 LED MNTR	0 to 12	-	-	0		A		
E44	(Display at STOP mode)	E44 LED MNTR2	0, 1	-	-	0		A		
E45	LCD Monitor (Function)	E45 LCD MNTR	0, 1	-	-	0		A		
E46	(Language)	E46 LANGUAGE	0 to 5	-	-	1		A		
E47	(Contrast)	E47 CONTRAST	0(soft) to 10(hard)	-	-	5		A		

C:Control Functions of Frequency

Func No.	NAME	LCD Display	Setting range	Unit	Min. Unit	Factory setting		Change during op	User Set value	Remark
						-30HP	40HP-			
C01	Jump frequency (Jump freq. 1)	C01 JUMP Hz 1	G11S: 0 to 400Hz P11S: 0 to 120Hz	Hz	1	0		A		
C02	(Jump freq. 2)	C02 JUMP Hz 2				0		A		
C03	(Jump freq. 3)	C03 JUMP Hz 3				0		A		
C04	(Hysteresis)	C04 JUMP HYSTR	0 to 30Hz	Hz	1	3		A		
C05	Multistep frequency setting (Freq. 1)	C05 MULTI Hz-1	G11S: 0.00 to 400.00Hz P11S: 0.00 to 120.00Hz	Hz	0.01	0.00		A		
C06	(Freq. 2)	C06 MULTI Hz-2				0.00		A		
C07	(Freq. 3)	C07 MULTI Hz-3				0.00		A		
C08	(Freq. 4)	C08 MULTI Hz-4				0.00		A		
C09	(Freq. 5)	C09 MULTI Hz-5				0.00		A		
C10	(Freq. 6)	C10 MULTI Hz-6				0.00		A		
C11	(Freq. 7)	C11 MULTI Hz-7				0.00		A		
C12	(Freq. 8)	C12 MULTI Hz-8				0.00		A		
C13	(Freq. 9)	C13 MULTI Hz-9				0.00		A		
C14	(Freq. 10)	C14 MULTI Hz-10				0.00		A		
C15	(Freq. 11)	C15 MULTI Hz-11				0.00		A		
C16	(Freq. 12)	C16 MULTI Hz-12				0.00		A		
C17	(Freq. 13)	C17 MULTI Hz-13				0.00		A		
C18	(Freq. 14)	C18 MULTI Hz-14				0.00		A		
C19	(Freq. 15)	C19 MULTI Hz-15				0.00		A		

Func No.	NAME	LCD Display	Setting range	Unit	Min. Unit	Factory setting		Change during op	User Set value	Remark
						-30HP	40HP-			
C20	JOG frequency	C20 JOG Hz	G11S:0.00 to 400.00Hz P11S:0.00 to 120.00Hz	Hz	0.01	5.00		A		
C21	PATTERN(Mode select) operation	C21 PATTERN	0,1,2	-	-	0		NA		
C22	(Stage 1) (Stage 2) (Stage 3) (Stage 4) (Stage 5) (Stage 6) (Stage 7)	C22 STAGE 1	Operation time:0.00 to 6000s F1 to F4 and R1 to R4	s	0.01	0.00 F1		A		
C23		C23 STAGE 2				0.00 F1		A		
C24		C24 STAGE 3				0.00 F1		A		
C25		C25 STAGE 4				0.00 F1		A		
C26		C26 STAGE 5				0.00 F1		A		
C27		C27 STAGE 6				0.00 F1		A		
C28		C28 STAGE 7				0.00 F1		A		
C30	Frequency command 2	C30 FREQ CMD 2	0 to 11	-	-	2		NA		
C31	Offset adjust(terminal[12])	C31 BIAS 12	-100.0 to +100.0%	%	0.1	0.0		A		
C32		C32 GAIN 12	0.0 to +200.0%	%	0.1	100.0		A		
C33	Analog setting signal filter	C33 REF FILTER	0.00 to 5.00s	s	0.01	0.05		A		

P:Motor Parameters

P01	Number of motor 1 poles	P01 M1 POLES	2 to 14	-	2	4		NA		
P02	Motor 1 (Capacity)	P02 M1-CAP	Up to 30[HP]: 0.01 to 60HP 40[HP]and above: 0.01 to 800HP	HP	0.01	Motor Capacity		NA		
P03	(Rated current)	P03 M1-Ir	0.00 to 2000A	A	0.01	Motor rated current		NA		
P04	(Tuning)	P04 M1 TUN1	0, 1, 2	-	-	0		NA		
P05	(On-line Tuning)	P05 M1 TUN2	0, 1	-	-	0		NA		
P06	(No-load current)	P06 M1-Io	0.00 to 2000A	A	0.01	Fuji STANDARD RATED VALUE		NA		
P07	(%R1 setting)	P07 M1-%R1	0.00 to 50.00%	%	0.01	Fuji STANDARD RATED VALUE		A		
P08	(%X setting)	P08 M1-%X	0.00 to 50.00%	%	0.01	Fuji STANDARD RATED VALUE		A		
P09	Slip compensation control 1	P09 SLIP COMP1	0.00 to 15.00Hz	Hz	0.01	0.00		A		

H:High Performance Functions

H03	Data initializing	H03 DATA INIT	0, 1	-	-	0		NA		
H04	Auto-reset (Times)	H04 AUTO-RESET	0, 1 to 10 times	-	1	0		A		
H05	(Reset interval)	H05 RESET INT	2 to 20s	s	1	5		A		
H06	Fan stop operation	H06 FAN STOP	0, 1	-	-	0		A		
H07	ACC/DEC pattern (Mode select)	H07 ACC PTN	0,1,2,3	-	-	0		NA		
H08	Rev. phase sequence lock	H08 REV LOCK	0, 1	-	-	0		NA		
H09	Start mode	H09 START MODE	0, 1, 2	-	-	0		NA		
H10	Energy-saving operation	H10 ENERGY SAV	0, 1	-	-	G11S:0 P11S:1		A		
H11	DEC mode	H11 DEC MODE	0, 1	-	-	0		A		
H12	Instantaneous OC limiting	H12 INST CL	0, 1	-	-	1		NA		
H13	Auto-restart (Restart time)	H13 RESTART t	0.1 to 10.0s	s	0.1	0.1		NA		
H14	(Freq. fall rate)	H14 FALL RATE	0.00 to 100.00Hz/s	Hz/s	0.01	10.00		A		
H15	(Holding DC voltage)	H15 HOLD V	3ph 230V class: 200 to 300V 3ph 460V class: 400 to 600V	V	1	230V class:235V 460V class:470V		A		
H16	(OPR command selfhold time)	H16 SELFHOLD t	0.0 to 30.0s, 999	s	0.1	999		NA		
H18	Torque control	H18 TRQ CTRL	G11:0, 1, 2, P11:0	-	-	0		NA		
H19	Active drive	H19 AUT RED	0, 1	-	-	0		A		
H20	PID control (Mode select)	H20 PID MODE	0, 1, 2	-	-	0		NA		
H21	(Feedback signal)	H21 FB SIGNAL	0, 1, 2, 3	-	-	1		NA		
H22	(P-gain)	H22 P-GAIN	0.01 to 10.00 times	-	0.01	0.1		A		
H23	(I-gain)	H23 I-GAIN	0.0, 0.1 to 3600s	s	0.1	0.0		A		
H24	(D-gain)	H24 D-GAIN	0.00s, 0.01 to 10.0s	s	0.01	0.00		A		
H25	(Feedback filter)	H25 FB FILTER	0.0 to 60.0s	s	0.1	0.5		A		
H26	PTC thermistor (Mode select)	H26 PTC MODE	0, 1	-	-	0		A		
H27	(Level)	H27 PTC LEVEL	0.00 to 5.00V	V	0.01	1.60		A		
H28	Droop operation	H28 DROOP	G11:-9.9 to 0.0Hz, P11:0.0 (Fixed.)	Hz	0.1	0.0		A		
H30	Serial link (Function select)	H30 LINK FUNC	0, 1, 2, 3	-	-	0		A		
H31	Modbus-RTU (Address)	H31 ADDRESS	0 (broadcast), 1 to 247	-	1	1		NA		
H32	(Mode select on no response error)	H32 MODE ON ER	0, 1, 2, 3	-	-	0		A		
H33	(Timer)	H33 TIMER	0.0 to 60.0s	s	0.1	2.0		A		
H34	(Baud rate)	H34 BAUD RATE	0, 1, 2, 3	-	-	1		A		
H35	(Data length)	H35 LENGTH	0 (8-bit fixed)	-	-	0		A		
H36	(Parity check)	H36 PARITY	0, 1, 2	-	-	0		A		
H37	(Stop bits)	H37 STOP BITS	0(2bit), 1(1bit)	-	-	0		A		
H38	(No response error detection time)	H38 NO RES t	0 (No detection), 1 to 60s	s	1	0		A		
H39	(Response interval)	H39 INTERVAL	0.00 to 1.00s	s	0.01	0.01		A		

A:Alternative Motor Parameters

Func No.	NAME	LCD Display	Setting range	Unit	Min. Unit	Factory setting		Change during op	User Set value	Remark
						-30HP	40HP-			
A01	Maximum frequency 2	A01 MAX Hz-2	G11S: 50 to 400Hz P11S: 50 to 120Hz	Hz	1	60		NA		
A02	Base frequency 2	A02 BASE Hz-2	G11S: 25 to 400Hz P11S: 25 to 120Hz	Hz	1	60		NA		
A03	Rated voltage 2 (at Base frequency 2)	A03 RATED V-2	0: 80 to 240V:(230V class) 320 to 480V:(460V class)	V	1	220:(230V class) 380:(460V class)		NA		
A04	Maximum voltage 2 (at Base frequency 2)	A04 MAX V-2	80 to 240V:(230V class) 320 to 480V:(460V class)	V	1	220:(230V class) 380:(460V class)		NA		
A05	Torque boost2	A05 TRQ BOOST2	0.0, 0.1 to 20.0	-	-	G11S:2.0 P11S:0.1		A		
A06	Electronic thermal overload relay for motor 2 (Select)	A06 ELCTRN OL2	0, 1, 2	-	-	1		A		
A07	(Level)	A07 OL LEVEL2	INV rated current 20%to135%	A	0.01	Motor rated current		A		
A08	(Thermal time constant)	A08 TIME CNST2	0.5 to 75.0 min	min	0.1	5.0	10.0	A		
A09	Torque vector control 2	A09 TRQVECTOR2	0, 1	-	-	0		NA		
A10	Number of motor-2 poles	A10 M2 POLES	2 to 14 poles	ploes	2	4		NA		
A11	Motor 2 (Capacity)	A11 M2-CAP	Up to 30HP:0.01 to 60HP 40HP and above:0.01to800HP	HP	0.01	Motor capacity		NA		
A12	(Rated current)	A12 M2-Ir	0.00 to 2000A	A	0.01	Motor rated current		NA		
A13	(Tuning)	A13 M2 TUN1	0, 1, 2	-	-	0		NA		
A14	(On-line Tuning)	A14 M2 TUN2	0, 1	-	-	0		NA		
A15	(No-load current)	A15 M2-Io	0.00 to 2000A	A	0.01	Fuji standard rated value		NA		
A16	(%R1 setting)	A16 M2-%R1	0.00 to 50.00%	%	0.01	Fuji standard rated value		A		
A17	(%X setting)	A17 M2-%X	0.00 to 50.00%	%	0.01	Fuji standard rated value		A		
A18	(Slip compensation control 2)	A18 SLIP COMP2	0.00 to 15.00Hz	Hz	0.01	0.00		A		

U>User Functions

U01	Maximum compensation frequency during braking torque limit	U01 USER 01	0 to 65535	-	1	75		A		
U02	1st S-shape level at acceleration	U02 USER 02	1 to 50%	%	1	10		NA		
U03	2nd S-shape level at acceleration	U03 USER 03	1 to 50%	%	1	10		NA		
U04	1st S-shape level at deceleration	U04 USER 04	1 to 50%	%	1	10		NA		
U05	2nd S-shape level at deceleration	U05 USER 05	1 to 50%	%	1	10		NA		
U08	Main DC link capacitor (Initial value)	U08 USER 08	0 to 65535	-	1	xxxx		A		
U09	(Measured value)	U09 USER 09	0 to 65535	-	1	0		A		
U10	PC board capacitor powered on time	U10 USER 10	0 to 65535h	h	1	0		A		
U11	Cooling fan operating time	U11 USER 11	0 to 65535h	h	1	0		A		
U13	Magnetize current vibration damping gain	U13 USER 13	0 to 32767	-	1	819	410	A		
U15	Slip compensation filter time constant	U15 USER 15	0 to 32767	-	1	556	546	A		
U23	Integral gain of continuous operation at power failure	U23 USER 23	0 to 65535	-	1	1738	1000	A		
U24	Proportional gain of continuous operation at power failure	U24 USER 24	0 to 65535	-	1	1024	1000	A		
U48	Input phase loss protection	U48 USER 48	0, 1, 2	-	-	-75HP 0	100HP- 1	NA		
U49	RS-485 protocol selection	U49 USER 49	0, 1	-	-	1		NA		
U56	Speed agreement (Detection width)	U56 USER 56	0 to 50%	%	1	10		A		
U57	/PG error (Detection timer)	U57 USER 57	0.0 to 10.0s	s	0.1	0.5				
U58	PG error selection	U58 USER 58	0, 1	-	-	1		NA		
U59	Braking-resistor function select(up to 30HP) Manufacturer's function(40HP or more)	U59 USER 59	00 to A8(HEX)	-	1	00		NA		
U60	Regeneration avoidance at deceleration	U60 USER 60	0, 1	-	-	0		NA		
U61	Voltage detect offset and gain adjustment	U61 USER 61	--30HP : 0(Fixed.) 40HP-- : 0, 1, 2	-	-	0		A		
U89	Motor overload memory retention	U89 USER 89	0,1	-	-	1		A		

Table 5-1-1 The factory setting value (details)

Inverter type		Function code					
		*2		*1 *2	*1 *2	*1	*1
		F11:Electric thermal1 (Level) E34:OL1 function(Level) E37:OL2 function(Level) A07:Electric thermal overload relay for motor2 (Level) [A]	P02:Motor1 (Capacity) A11:Motor2 (Capacity) [HP]	P03:Motor1 (Rated current) A12:Motor2 (Rated current) [A]	P06:Motor1 (No-load current) A15:Motor2 (No-load current) [A]	P07:Motor1 (%R1 setting) A16:Motor2 (%R1 setting) [%]	P08:Motor1 (%X setting) A17:Motor2 (%X setting) [%]
230V G11S	FRNF25G11S-2UX	1.40	0.25	1.40	1.12	11.02	13.84
	FRNF50G11S-2UX	2.00	0.50	2.00	1.22	6.15	8.80
	FRN001G11S-2UX	3.00	1.00	3.00	1.54	3.96	8.86
	FRN002G11S-2UX	5.80	2.00	5.80	2.80	4.29	7.74
	FRN003G11S-2UX	7.90	3.00	7.90	3.57	3.15	20.81
	FRN005G11S-2UX	12.6	5.00	12.6	4.78	3.34	23.57
	FRN007G11S-2UX	18.6	7.50	18.6	6.23	2.65	28.91
	FRN010G11S-2UX	25.3	10.00	25.3	8.75	2.43	30.78
	FRN015G11S-2UX	37.3	15.00	37.3	12.7	2.07	29.13
	FRN020G11S-2UX	49.1	20.00	49.1	9.20	2.09	29.53
	FRN025G11S-2UX	60.0	25.00	60.0	16.7	1.75	31.49
	FRN030G11S-2UX	72.4	30.00	72.4	19.8	1.90	32.55
	FRN040G11S-2UX	91.0	40.00	91.0	13.6	1.82	25.32
	FRN050G11S-2UX	115.0	50.00	115.0	18.7	1.92	24.87
	FRN060G11S-2UX	137.0	60.00	137.0	20.8	1.29	26.99
FRN075G11S-2UX	174.0	75.00	174.0	28.6	1.37	27.09	
FRN100G11S-2UX	226.0	100.00	226.0	37.4	1.08	23.80	
FRN125G11S-2UX	268.0	125.00	268.0	29.8	1.05	22.90	
230V P11S	FRN007P11S-2UX	18.6	7.50	18.6	6.23	2.65	28.91
	FRN010P11S-2UX	25.3	10.00	25.3	8.75	2.43	30.78
	FRN015P11S-2UX	37.3	15.00	37.3	12.7	2.07	29.13
	FRN020P11S-2UX	49.1	20.00	49.1	9.20	2.09	29.53
	FRN025P11S-2UX	60.0	25.00	60.0	16.7	1.75	31.49
	FRN030P11S-2UX	72.4	30.00	72.4	19.8	1.90	32.55
	FRN040P11S-2UX	91.0	40.00	91.0	13.6	1.82	25.32
	FRN050P11S-2UX	115.0	50.00	115.0	18.7	1.92	24.87
	FRN060P11S-2UX	137.0	60.00	137.0	20.8	1.29	26.99
	FRN075P11S-2UX	174.0	75.00	174.0	28.6	1.37	27.09
	FRN100P11S-2UX	226.0	100.00	226.0	37.4	1.08	23.80
FRN125P11S-2UX	268.0	125.00	268.0	29.8	1.05	22.90	
FRN150P11S-2UX	337.0	150.00	337.0	90.4	0.96	21.61	

Inverter type		Function code					
		*2		*1 *2	*1 *2	*1	*1
		F11:Electric thermal1(Level) E34:OL1 function(Level) E37:OL2 function(Level) A07:Electric thermal overload relay for motor2 (Level)	P02:Motor1 (Capacity) A11:Motor2 (Capacity)	P03:Motor1 (Rated current) A12:Motor2 (Rated current)	P06:Motor1 (No-load current) A15:Motor2 (No-load current)	P07:Motor1 (%R1 setting) A16:Motor2 (%R1 setting)	P08:Motor1 (%X setting) A17:Motor2 (%X setting)
		[A]	[HP]	[A]	[A]	[%]	[%]
460V G11S	FRNF50G11S-4UX	1.00	0.50	1.00	0.61	6.15	8.80
	FRN001G11S-4UX	1.50	1.00	1.50	0.77	3.96	8.86
	FRN002G11S-4UX	2.90	2.00	2.90	1.40	4.29	7.74
	FRN003G11S-4UX	4.00	3.00	4.00	1.79	3.15	20.81
	FRN005G11S-4UX	6.30	5.00	6.30	2.39	3.34	23.57
	FRN007G11S-4UX	9.30	7.50	9.30	3.12	2.65	28.91
	FRN010G11S-4UX	12.7	10.00	12.7	4.37	2.43	30.78
	FRN015G11S-4UX	18.7	15.00	18.7	6.36	2.07	29.13
	FRN020G11S-4UX	24.6	20.00	24.6	4.60	2.09	29.53
	FRN025G11S-4UX	30.0	25.00	30.0	8.33	1.75	31.49
	FRN030G11S-4UX	36.2	30.00	36.2	9.88	1.90	32.55
	FRN040G11S-4UX	45.5	40.00	45.5	6.80	1.82	25.32
	FRN050G11S-4UX	57.5	50.00	57.5	9.33	1.92	24.87
	FRN060G11S-4UX	68.7	60.00	68.7	10.40	1.29	26.99
	FRN075G11S-4UX	86.9	75.00	86.9	14.30	1.37	27.09
	FRN100G11S-4UX	113.0	100.00	113.0	18.70	1.08	23.80
	FRN125G11S-4UX	134.0	125.00	134.0	14.90	1.05	22.90
	FRN150G11S-4UX	169.0	150.00	169.0	45.20	0.96	21.61
	FRN200G11S-4UX	231.0	200.00	231.0	81.80	0.72	20.84
	FRN250G11S-4UX	272.0	250.00	272.0	41.10	0.71	18.72
FRN300G11S-4UX	323.0	300.00	323.0	45.10	0.53	18.44	
FRN350G11S-4UX	375.0	350.00	375.0	68.30	0.99	19.24	
FRN400G11S-4UX	429.0	400.00	429.0	80.70	1.11	18.92	
FRN450G11S-4UX	481.0	450.00	481.0	85.50	0.95	19.01	
FRN500G11S-4UX	534.0	500.00	534.0	99.20	1.05	18.39	
FRN600G11S-4UX	638.0	600.00	638.0	140.00	0.85	18.38	
460V P11S	FRN007P11S-4UX	9.30	7.50	9.30	3.12	2.65	28.91
	FRN010P11S-4UX	12.7	10.00	12.7	4.37	2.43	30.78
	FRN015P11S-4UX	18.7	15.00	18.7	6.36	2.07	29.13
	FRN020P11S-4UX	24.6	20.00	24.6	4.60	2.09	29.53
	FRN025P11S-4UX	30.0	25.00	30.0	8.33	1.75	31.49
	FRN030P11S-4UX	36.2	30.00	36.2	9.88	1.90	32.55
	FRN040P11S-4UX	45.5	40.00	45.5	6.80	1.82	25.32
	FRN050P11S-4UX	57.5	50.00	57.5	9.33	1.92	24.87
	FRN060P11S-4UX	68.7	60.00	68.7	10.40	1.29	26.99
	FRN075P11S-4UX	86.9	75.00	86.9	14.30	1.37	27.09
	FRN100P11S-4UX	113.0	100.00	113.0	18.70	1.08	23.80
	FRN125P11S-4UX	134.0	125.00	134.0	14.90	1.05	22.90
	FRN150P11S-4UX	169.0	150.00	169.0	45.20	0.96	21.61
	FRN200P11S-4UX	231.0	200.00	231.0	81.80	0.72	20.84
	FRN250P11S-4UX	272.0	250.00	272.0	41.10	0.71	18.72
	FRN300P11S-4UX	323.0	300.00	323.0	45.10	0.53	18.44
	FRN350P11S-4UX	375.0	350.00	375.0	68.30	0.99	19.24
	FRN400P11S-4UX	429.0	400.00	429.0	80.70	1.11	18.92
	FRN450P11S-4UX	481.0	450.00	481.0	85.50	0.95	19.01
	FRN500P11S-4UX	534.0	500.00	534.0	99.20	1.05	18.39
FRN600P11S-4UX	638.0	600.00	638.0	140.00	0.85	18.38	
FRN700P11S-4UX	756.0	700.00	756.0	164.00	1.02	21.92	
FRN800P11S-4UX	870.0	800.00	870.0	209.00	1.17	21.69	

note 1) The factory setting described on *1 is the value of Fuji standard induction motor 460V/50Hz/4-poles.
The factory setting described on *1 is NOT changed automatically even function code P01/A10 (motor poles) is changed to excluding 4-poles.

note 2) The minimum units of the data *2 is as follows.

Current value [A]	Minimum units [A]
0.00 to 9.99	0.01
10.0 to 99.9	0.1
100 to 999	1
1000 to 9990	10

5-2 Function Explanation

F: Fundamental function

F00

Data protection

- ◆ Setting can be made so that a set value cannot be changed by keypad panel operation.

F 0 0 D A T A P R T C

Related functions
E01 to E09
(Set values 19)

Setting range 0 : The data can be changed.
1 : The data cannot be changed.

[Setting procedure]

0 to 1: Press the **STOP** and **▲** keys simultaneously

to change the value from 0 to 1, then press the **FUNC DATA** to validate the change.

1 to 0: Press the **STOP** and **▼** keys simultaneously

to change the value from 1 to 0, then press the **FUNC DATA** key to validate the change.

F01

Frequency command 1

- ◆ This function selects the frequency setting method.

F 0 1 F R E Q C M D 1

Related functions
E01 to E09
(Set values 17,18)
C30

0 : Setting by keypad panel operation (**▲** **▼** key)

1 : Setting by voltage input (terminal [12](0 to +10V)
+ terminal [V2](0 to +10V))

2: Setting by current input (terminal [C1] (4 to 20mA)).

3: Setting by voltage input + current input (terminal [12]
+ terminal [C1]) (-10 to +10V + 4 to 20mA).

4: Reversible operation with polarity (terminal [12]
(-10 to +10V))

5: Reversible operation with polarity (terminal [12]
+[V2]+[V1](Option) (-10 to +10V))

6: Inverse mode operation
(terminal [12] +[V2] (+10V to 0))

7: Inverse mode operation
(terminal [C1] (20 to 4mA))

8: Setting by UP/DOWN control mode 1
(initial value = 0) (terminals [UP] and [DOWN])

9: Setting by UP/DOWN control mode 2
(initial value =last final value)
(terminals [UP] and [DOWN])

See the function explanation of E01 to E09 for details.

10: Setting by pattern operation

See the function explanation C21 to C28 for details.

11: Setting by digital input or pulse train

* Optional. For details, see the instruction manual on options.

Related functions:
E01 to E09
(Set value 21)

Related functions:
E01 to E09
(Set value 17,18)

Related functions:
C21to C28

Forward / Inverse operation

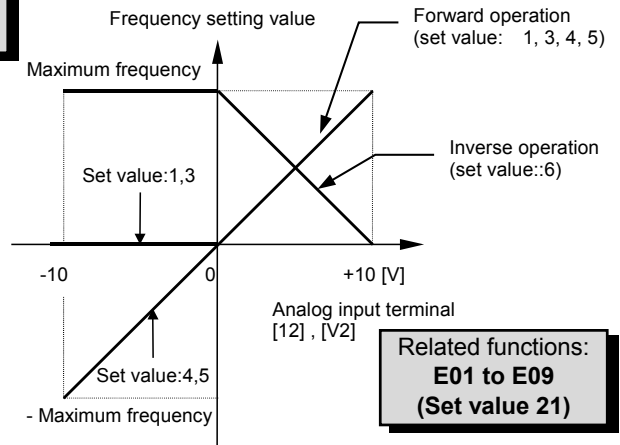

Related functions:
E01 to E09
(Set value 21)

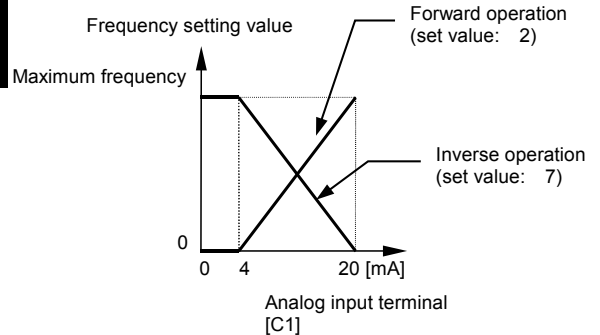

F02

Operation method

- ◆ This function sets the operation command input method.

F 0 2 O P R M E T H O D

Setting range 0: Key pad operation

(**FWD** **REV** **STOP** keys).

Press the **FWD** for forward operation.

Press the **REV** for reverse operation.

Press the **STOP** for deceleration to a stop.

Input from terminals [FWD] and [REV] is ignored.

(LOCAL)

1: Terminal operation(**STOP** key active)

2: Terminal operation(**STOP** key inactive)

3: Terminal operation(**STOP** key active)
with Fuji start software.

4: Terminal operation(**STOP** key inactive)
with Fuji start software.

* - This function can only be changed when terminals FWD and REV are open.

- REMOTE/LOCAL switching from the keypad panel automatically changes the set value of this function.

- REMOTE/LOCAL can be changed by pressing the **STOP** key and **RESET** key simultaneously.

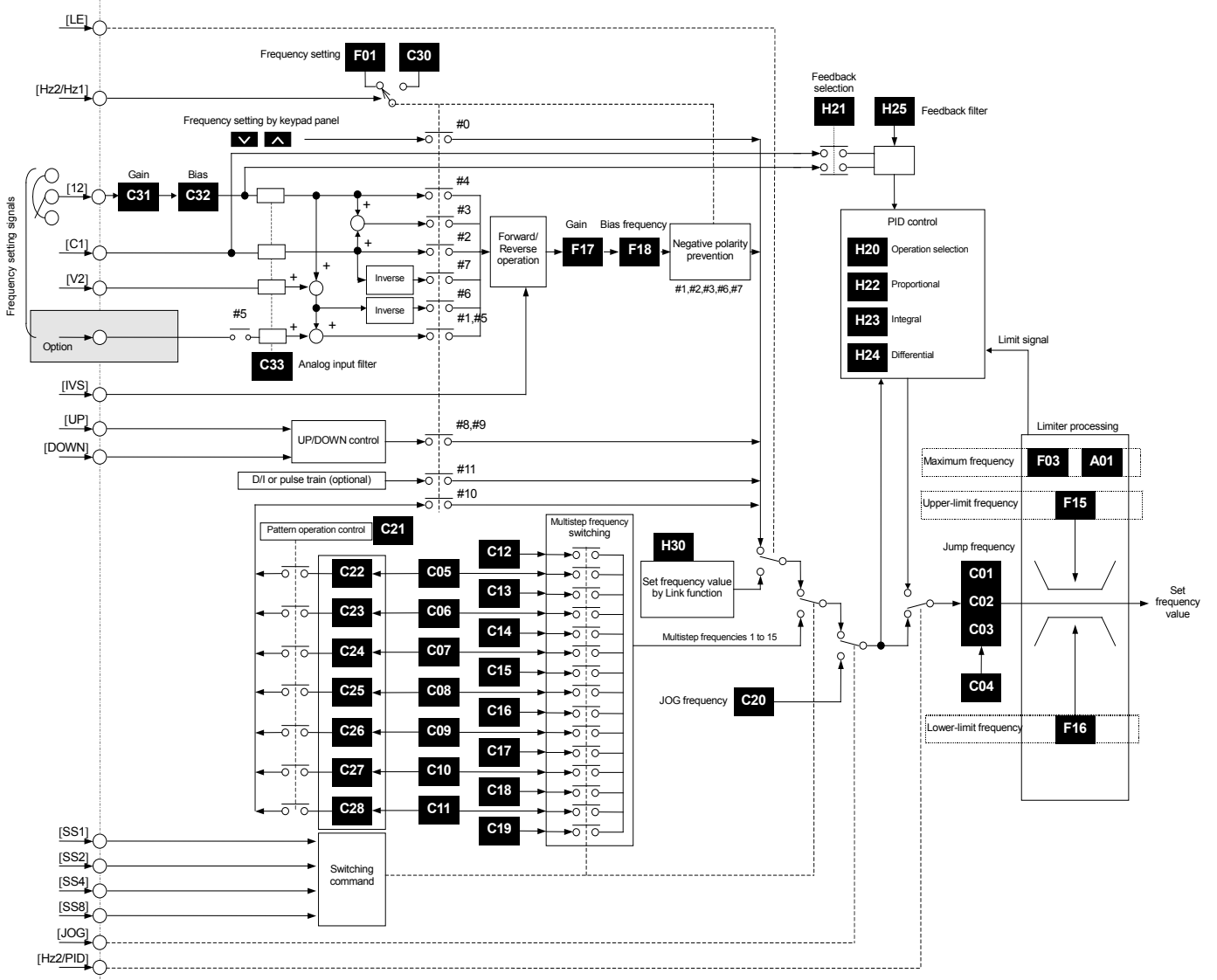

note) The numbers marked "#" means the setting value of each functions.

Frequency setting block diagram

F03 Maximum frequency 1

- ◆ This function sets the maximum output frequency for motor 1.
- ◆ This is a function for motor 1.

F 0 3 M A X H z - 1

Setting range G11S: 50 to 400 Hz
P11S: 50 to 120Hz

Setting a value higher than the rated value of the device to be driven may damage the motor or machine. Match the rating of the device.

F04 Base frequency 1

- ◆ This function sets the maximum output frequency in the constant-torque range of motor 1 or the output frequency at the rated output voltage. Match the rating of the motor.
- ◆ This is a function for motor 1.

F 0 4 B A S E H z - 1

Setting range G11S: 25 to 400Hz
P11S: 25 to 120Hz

Note: When the set value of base frequency 1 is higher than that of maximum output frequency 1, the output voltage does not increase to the rated voltage because the maximum frequency limits the output frequency.

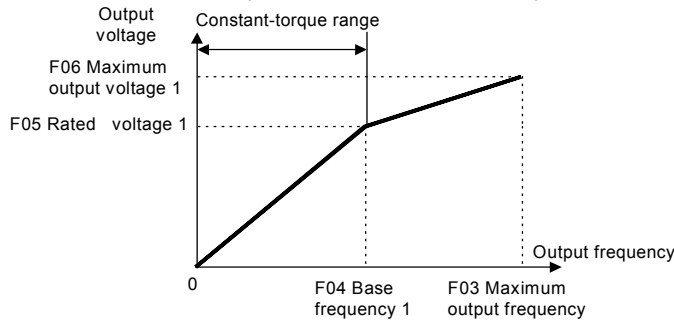

F05 Rated voltage 1

- ◆ This function sets the rated value of the voltage output to motor 1. Note that a voltage greater than the supply (input) voltage cannot be output.
- ◆ This is a function for motor 1.

F 0 5 R A T E D V - 1

Setting range 230 V series: 0, 80 to 240V
460 V series: 0, 320 to 480V

Value 0 terminates operation of the voltage regulation function, thereby resulting in the output of a voltage proportional to the supply voltage.

Note: When the set value of rated voltage 1 exceeds maximum output voltage 1, the output voltage does not increase to the rated voltage because the maximum output voltage limits the output voltage.

F06 Maximum voltage 1

- ◆ This function sets the maximum value of the voltage output for motor 1. Note that a voltage higher than the supply (input) voltage cannot be output.
- ◆ This is a function for motor 1.

F 0 6 M A X V - 1

Setting range 230 V series: 80 to 240V
460 V series: 320 to 480V

Note: When the set value of rated voltage 1 (F05) to "0", this function is invalid.

F07 Acceleration time 1

F08 Deceleration time 1

- ◆ This function sets the acceleration time for the output frequency from startup to maximum frequency and the deceleration time from maximum frequency to operation stop.

F 0 7 A C C T I M E 1
F 0 8 D E C T I M E 1

Setting range Acceleration time 1: 0.01 to 3,600 seconds
Deceleration time 1: 0.01 to 3,600 seconds

Acceleration and deceleration times are represented by the three most significant digits, thereby the setting of three high-order digits can be set.

Set acceleration and deceleration times with respect to maximum frequency. The relationship between the set frequency value and acceleration/deceleration times is as follows:

Set frequency = maximum frequency

The actual operation time matches the set value.

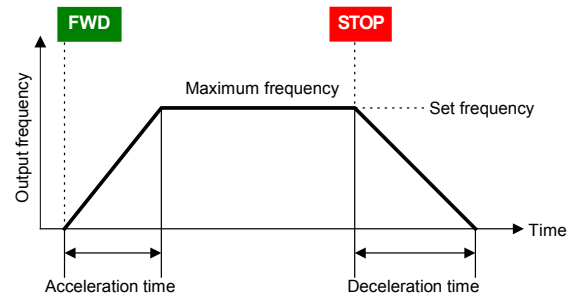

Set frequency < maximum frequency

The actual operation time differs from the set value.

Acceleration(deceleration) operation time = set value x (set frequency/maximum frequency)

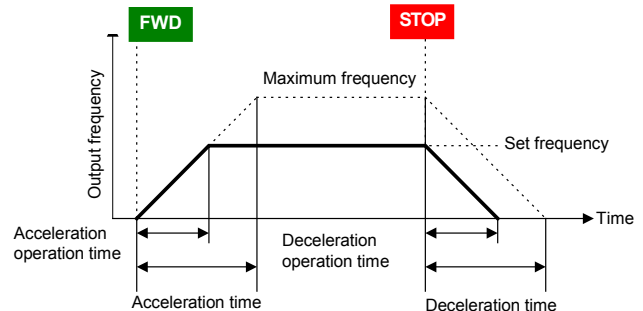

Note: If the set acceleration and deceleration times are too short even though the resistance torque and moment of inertia of the load are great, the torque limiting function or stall prevention function becomes activated, thereby prolonging the operation time beyond that stated above.

F09 Torque boost 1

◆ This is a function for motor 1. The following can be selected:

F 0 9 T R Q B O O S T 1

- Selection of load characteristics such as automatic torque boost, square law reduction torque load, proportional torque load, constant torque load.
- Enhancement of torque (V/f characteristics), which is lowered during low-speed operation. Insufficient magnetic flux of the motor due to a voltage drop in the low-frequency range can be compensated.

Setting range	Characteristics selected
0.0	Automatic torque boost characteristic where the torque boost value of a constant torque load (a linear change) is automatically adjusted. The motor tuning (P04 / A13) should be set to "2" for this function is valid.
0.1 to 0.9	Square law reduction torque for fan and pump loads.
1.0 to 1.9	Proportional torque for middle class loads between square law reduction torque and constant torque (linear change)
2.0 to 20.0	Constant torque (linear change)

◆ Torque characteristics(30HP or less)
 <Square law reduction torque> <Proportional torque>

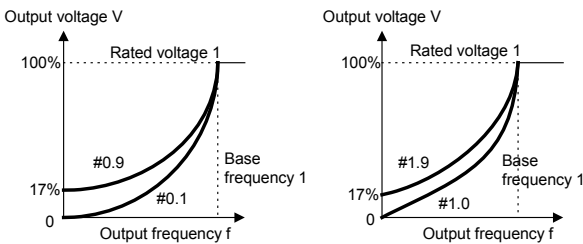

<Constant torque>

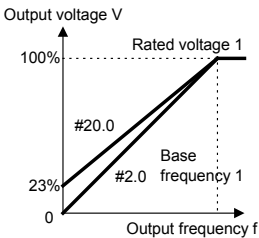

◆ Torque characteristics(40HP or above)
 <Square law reduction torque> <Proportional torque>

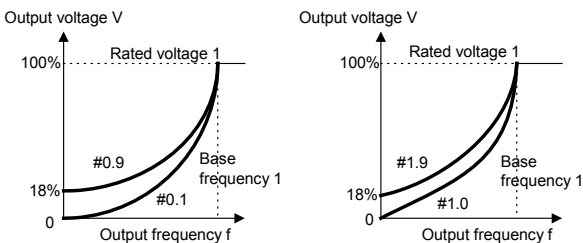

<Constant torque>

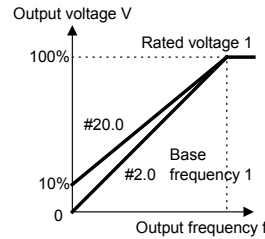

Note: As a large torque boost value creates overexcitation in the low-speed range, continued operation may cause the motor to overheat. Check the characteristics of the driven motor.

- F10 Electric thermal O/L relay (select)**
- F11 Electric thermal O/L relay (level)**
- F12 Electric thermal O/L relay (Thermal time constant)**

The electronic thermal O/L relay manages the output frequency, output current, and operation time of the inverter to prevent the motor from overheating when 150% of the set current value flows for the time set by F12 (thermal time constant).

- ◆ This is a function for motor 1.
- ◆ This function specifies whether to operate the electronic thermal O/L relay and selects the target motor. When a general-purpose motor is selected, the operation level is lowered in the low speed range according to the cooling characteristics of the motor.

F 1 0 E L C T R N O L 1

- Set value 0: Inactive
 1: Active (for general-purpose motor)
 2: Active (for inverter motor)

- ◆ This function sets the operation level (current value) of the electronic thermal. Enter a value from 1 to 1.1 times the current rating value of the motor.
- ◆ The set value "2" is set for the inverter motor because there is no cooling effect decrease by the rotational speed.

F 1 1 O L L E V E L 1

The setting range is 20 to 135% of the rated current of the inverter.

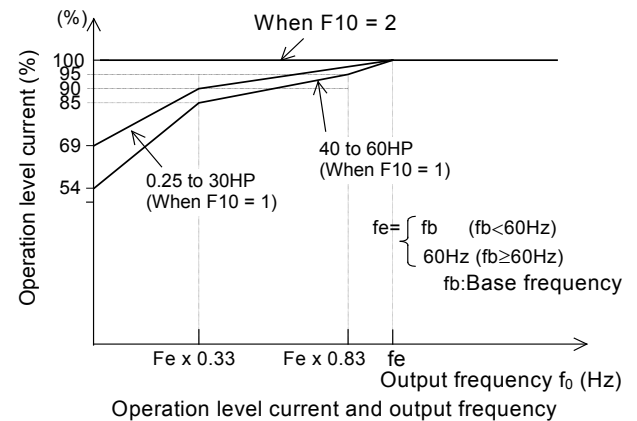

F13 Electric thermal O/L relay (for braking resistor)

This function controls the frequent use and continuous operating time of the braking resistor to prevent the resistor from overheating.

Related functions:
U59

F 1 3 D B R O L

Inverter capacity	Operation
G11S: 10HP or less	0: Inactive 1: Active (built-in braking resistor) 2: Active (DB***-2C/4C external braking resistor)
P11S: 15HP or less	0: Inactive 2: Active (DB***-2C/4C external braking resistor)
G11S: 15HP or more P11S: 20HP or more	0: Inactive

◆When the setting value is selected to "2", the type of braking resistor and connection circuit are set by U59. The details are referred to the function : U59.

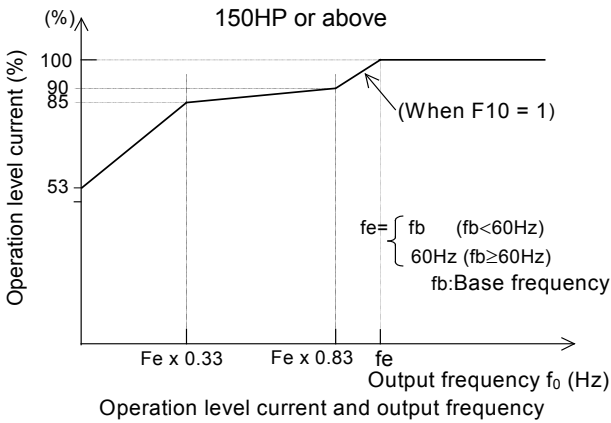
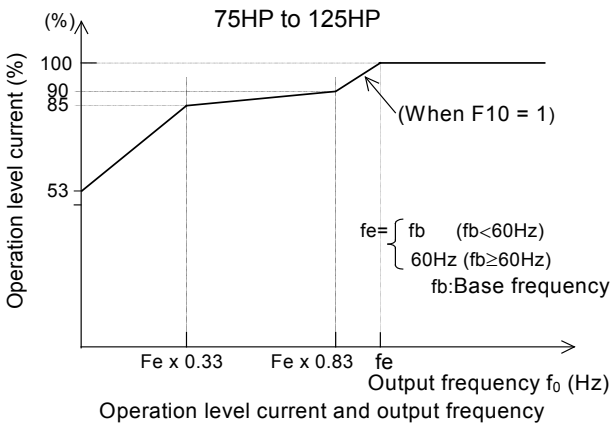

◆The time from when 150% of the operation level current flows continuously to when the electronic thermal O/L relay activates can be set. The setting range is 0.5 to 75.0 minutes (in 0.1 minute steps).

F 1 2 T I M E C N S T 1

Current-Operation time Characteristics

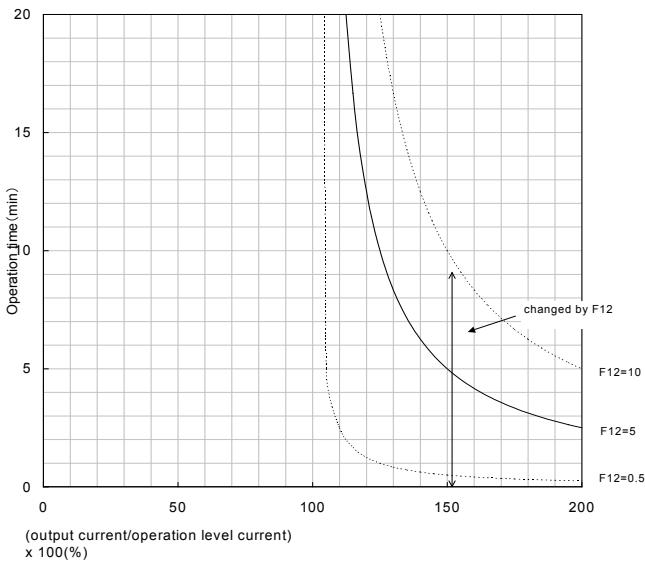

F14**Restart mode after momentary power failure**

- ◆ This function selects operation if a momentary power failure occurs.

The function for detecting power failure and activating protective operation (i.e., alarm output, alarm display, inverter output cutoff) for undervoltage can be selected. The automatic restart function (for automatically restarting a coasting motor without stopping) when the supply voltage is recovered can also be selected.

- ◆ When setting value is selected "2" or "3", both integration constant and the proportional constant during operation ride-through can be adjusted by the function code : U23 and U24. The details are referred to the function code : U23 and U24.

F 1 4 R E S T A R T

Related functions:
U23, U24

Setting range: 0 to 5

The following table lists the function details.

Set value	Function name	Operation at power failure	Operation at power recovery
0	Inactive (immediate inverter trip)	If undervoltage is detected, the drive will immediately trip and an undervoltage fault (LU) is displayed. The drive output stops and the motor will coast to a stop.	The drive operation is not automatically restarted. Input a reset command and operation command to restart operation.
1	Inactive (inverter trip at recovery)	If undervoltage is detected, the drive output stops and the motor will immediately coast to a stop. A drive fault is not activated	An undervoltage fault (LU) is activated at power recovery. Drive operation is not automatically restarted. Input a reset command to restart operation.
2	Inactive (inverter trip after deceleration to a stop at power failure) ^{Note1}	When the DC bus voltage reaches the continue operation voltage level (H15), a controlled deceleration to a stop occurs. The inverter collects the inertia energy of the load to maintain the DC bus voltage and controls the motor until it stops, then an undervoltage fault (LU) is activated. The drive will automatically decrease the deceleration time if necessary. If the amount of inertia energy from the load is small, and the undervoltage level is achieved before the motor stops, the undervoltage fault is immediately activated and the motor will coast to a stop.	The drive operation is not automatically restarted. Input a reset command and operation command to restart operation.
3	Active (operation ride through, for high-inertia loads) ^{Note1}	When the DC bus voltage reaches the continue operation voltage level (H15), energy is collected from the inertia of the load to maintain the DC bus voltage and extend the ride through time. The drive will automatically adjust the deceleration rate to maintain DC bus voltage level. If undervoltage is detected, the protective function is not activated, but drive output stops and the motor coast to a stop.	Operation is automatically restarted. For power recovery during ride-through the drive will accelerate directly to the original frequency. If undervoltage is detected, operation automatically restarts with the frequency at the time that the undervoltage is detected.
4	Active (restart with the frequency at power failure) ^{Note1}	If undervoltage is detected, the protective function is not activated. The drive output stops and the motor will coast to a stop.	Operation is automatically restarted with the frequency at power failure.
5	Active (restart with the start frequency, for low-inertia loads) ^{Note1}	If undervoltage is detected, the protective function is not activated, but output stops.	Operation is automatically restarted with the frequency set by F23, "Starting frequency."

Note1) When the function code H18(Torque control) is excluding "0" and Motor 1 is selected, the inverter will trip at power recovery if function code F14 is set to between "2" and "5". This operation is same as F14 is set to "1".

Function codes H13 to H16 are provided to control a restarting operation after momentary power failure. These functions should be understood and used. The pick-up (speed search) function can also be selected as a method of restarting when power is recovered following a momentary failure. (For setting details, see function code H09.)

The pick-up function searches for the speed of the coasting motor to restart the motor without subjecting it to excessive shock. In a high-inertia system, the reduction in motor speed is minimal even when the motor is coasting. A speed searching time is required when the pick-up function is active. In such a case, the original frequency may be recovered sooner when the function is inactive and the operation restarted with the frequency prior to the momentary power failure.

The pick-up function works in the range of 5 to 100 Hz. If the detected speed is outside this range, restart the motor using the regular restart function.



WARNING

- Automatically restart could be provided at power recovered, if "Restart mode after momentary power failure" is valid.
- The machine should be designed to securing the human safe even restarting.
Accident may result.

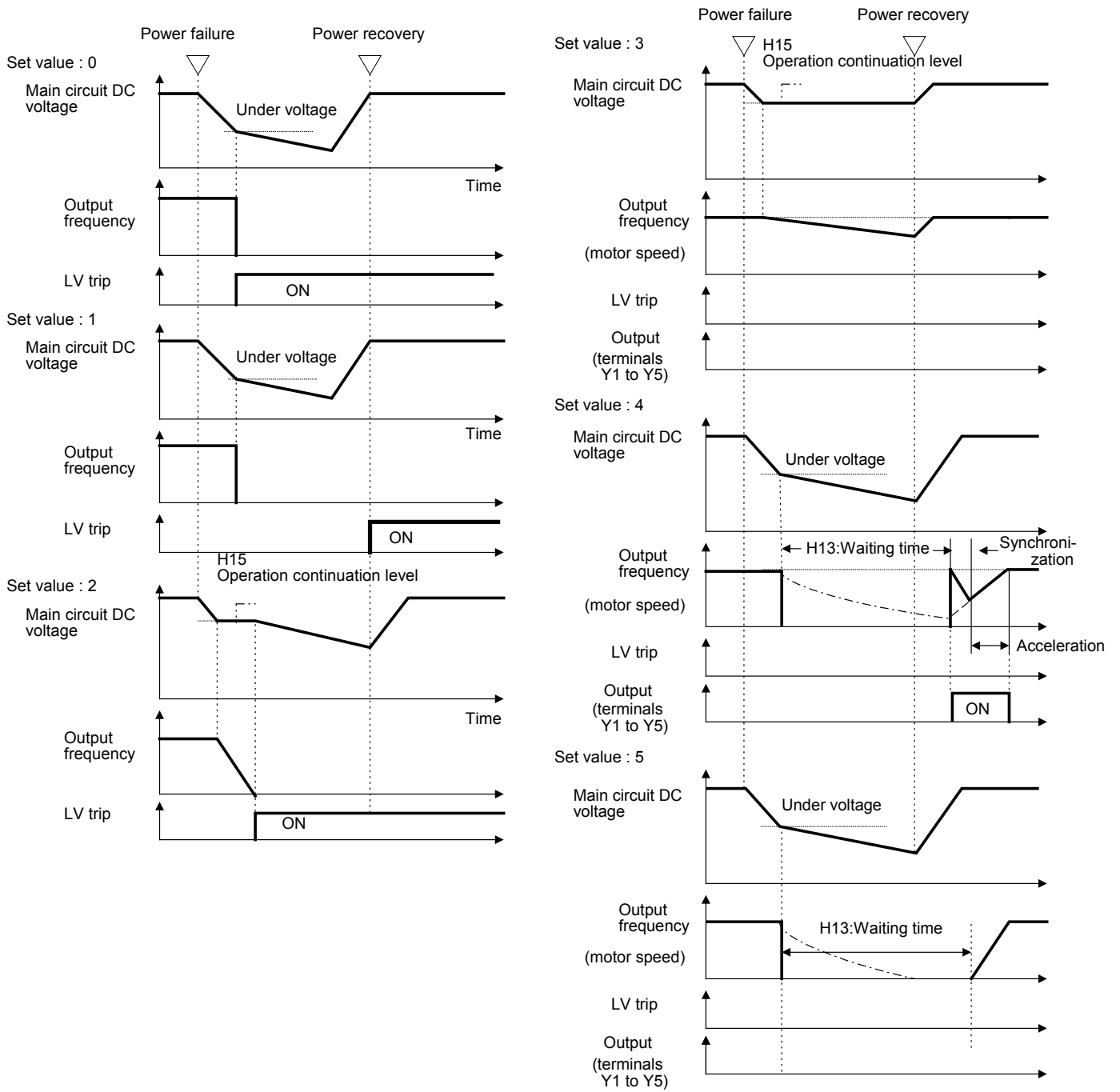

Note : Dotted-dashed lines indicate motor speed.

F15 **Frequency limiter (High)**

F16 **Frequency limiter (Low)**

◆ This function sets the upper and lower limits for the setting frequency.

F 1 5 H L I M I T E R
F 1 6 L L I M I T E R

Setting range G11S: 0 to 400Hz
 P11S: 0 to 120Hz

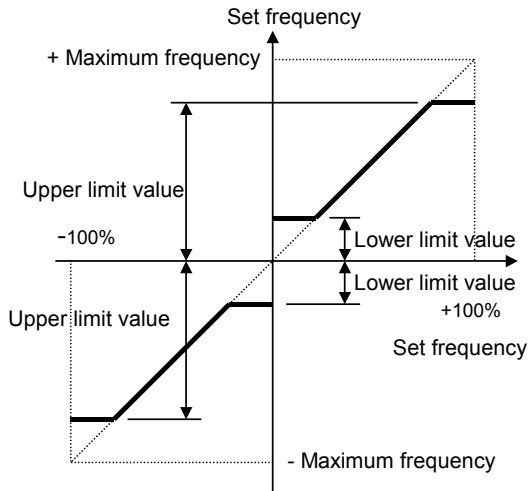

- ※ The inverter output starts with the start frequency when operation begins, and stops with the stop frequency when operation ends.
- ※ If the upper limit value is less than the lower limit value, the upper limit value overrides the lower limit value.
- ※ When lower limit value is set, the inverter operates with lower limit value at operation command is "ON" even frequency command is zero(0Hz).

F17 **Gain**

◆ This function sets the rate of the set frequency value to analog input.

F 1 7 F R E Q G A I N

Operation follows the figure below.

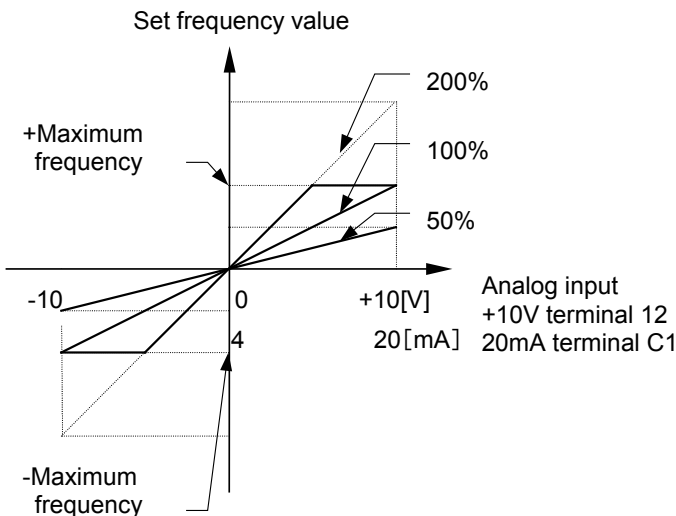

F18 **Bias frequency**

◆ This function adds a bias frequency to the set frequency value to analog input.

F 1 8 F R E Q B I A S

Setting range G11S: -400.0 to +400.0Hz
 P11S: -120.0 to +120.0Hz

The operation follows the figure below.
 When the bias frequency is higher than the maximum frequency or lower than the - maximum frequency, it is limited to the maximum or - maximum frequency.

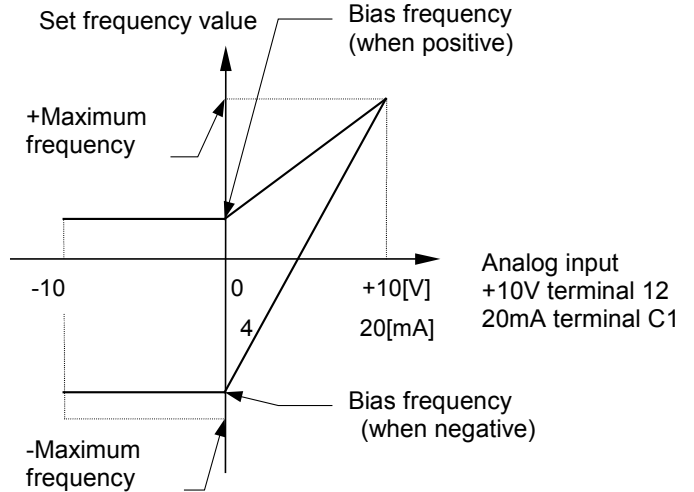

- ※ Reversible operation is valid if the function code F01/C30 is set to "4" or "5" only.
- ※ This function is invalid if PID control is selected(H20 is "1" or "2").

F20 **DC brake (starting frequency)**

F21 **DC brake (Braking level)**

F22 **DC brake (Braking time)**

◆ Starting frequency: This function sets the frequency with which to start a DC injection brake to decelerate the motor to a stop.

F 2 0 D C B R K H z

Setting range: 0 to 60Hz

◆ Operation level: This function sets the output current level when a DC injection brake is applied. Set a percentage of inverter rated output current in 1% steps.

F 2 1 D C B R K L V L

Setting range G11S: 0 to 100%
 P11S: 0 to 80%

◆ Time: This function sets the time of a DC injection brake operation.

F 2 2 D C B R K t

Setting range 0.0: Inactive
 0.1 to 30.0 seconds

! CAUTION

Do not use the inverter brake function for mechanical holding.
Injury may result.

F23	Starting frequency (frequency)
F24	Start frequency (Holding time)
F25	Stop frequency

The starting frequency can be set to reserve the torque at startup and can be sustained until the magnetic flux of the motor is being established.

◆ Frequency: This function sets the frequency at startup.

F 2 3 S T A R T H z

Setting range: 0.1 to 60Hz

◆ Holding time: This function sets the holding time during which the start frequency is sustained at startup.

F 2 4 H O L D I N G t

Set values: 0.1 to 10.0 seconds

*The holding time does not apply at the time of switching between forward and reverse.

*The holding time is not included in the acceleration time.

*The holding time also applies when pattern operation (C21) is selected. The holding time is included in the timer value.

◆ This function sets the frequency at stop.

F 2 5 S T O P H z

Setting range: 0.0 to 60.0Hz

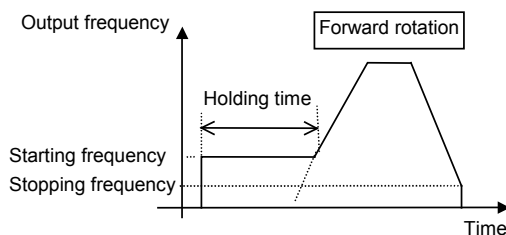

The operation does not start when the starting frequency is less than the stopping frequency or when the setting frequency is less than the stopping frequency.

F26 Motor sound (carrier frequency)

◆ This function adjusts the carrier frequency, correct adjustment of which prevents resonance with the machine system, reduces motor and inverter noise, and also reduces leakage current from output circuit wiring.

F 2 6 M T R S O U N D

	Nominal applied motor	Setting range
G11	75HP or less	0.75 to 15kHz
	100HP or more	0.75 to 10kHz
P11	30HP or less	0.75 to 15kHz
	40HP to 100HP	0.75 to 10kHz
	125HP or more	0.75 to 6kHz

Carrier frequency	Low	High
Motor noise	High	Low
Output current waveform	Bad	Good
Leakage current	Small amount	Large amount
Noise occurrence	Extremely low	High

Notes:

- Reducing the set value adversely affects the output current waveform (i.e., higher harmonics), increases motor loss, and raises motor temperature. For example, at 0.75kHz, reduce the motor torque by about 15%.
- Increasing the set value increases inverter loss and raises inverter temperature.

F27 Motor sound (sound tone)

◆ The tone of motor noise can be altered when the carrier frequency is 7kHz or lower. Use this function as required.

F 2 7 M T R T O N E

Setting range: 0, 1, 2, 3

F30 FMA (voltage adjust)

F31 FMA (function)

Monitor data (e.g., output frequency, output current) can be output to terminal FMA as a DC voltage. The amplitude of the output can also be adjusted.

◆ This function adjusts the voltage value of the monitor item selected in F31 when the monitor amount is 100%. A value from 0 to 200 (%) can be set in 1% steps.

F 3 0 F M A V - A D J

Setting range: 0 to 200%

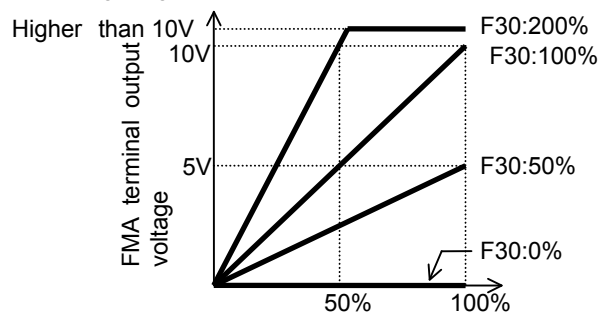

◆ This function selects the monitor item to be output to terminal FMA.

F 3 1 F M A F U N C

Set value	Monitor item	Definition of 100% monitor amount
0	Output frequency 1 (before slip compensation)	Maximum output frequency
1	Output frequency 2 (after slip compensation)	Maximum output frequency
2	Output current	Rated output current of inverter x 2
3	Output voltage	230V series: 250V 460V series: 500V
4	Output torque	Rated torque of motor x 2
5	Load rate	Rated load of motor x 2
6	Power consumption	Rated output of inverter x 2
7	PID feedback amount	Feedback amount of 100%
8	PG feedback amount (only when option is installed)	Synchronous speed at maximum frequency
9	DC link circuit voltage	230V series: 500V 460V series: 1,000V
10	Universal AO	0 to 10V output through communication and not related to inverter operation.

※The power consumption shows "0" during regenerative load.

F33	FMP (pulse rate)
F34	FMP (voltage adjust)
F35	FMP terminal (function)

Monitor data (e.g., output frequency, output current) can be output to terminal FMP as pulse voltage. Monitor data can also be sent to an analog meter as average voltage.

When sending data to a digital counter or other instrument as pulse output, set the pulse rate in F33 to any value and the voltage in F34 to 0%.

When data is sent to an analog meter or other instrument as average voltage, the voltage value set in F34 determines the average voltage and the pulse rate in F33 is fixed to 2670 (p/s).

- ◆ This function sets the pulse frequency of the monitor item selected in F35 within a range of 300 to 6000 (p/s) in 1 p/s steps.

F 3 3 F M P P U L S E S

Setting range: 300 to 6,000 p/s

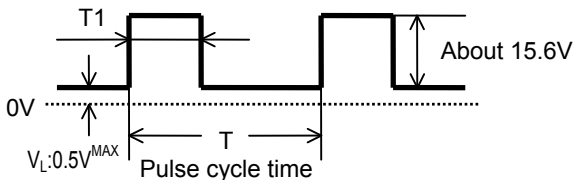

$$\text{Pulse frequency (p/s)} = 1/T$$

$$\text{Duty (\%)} = T1/T \times 100$$

$$\text{Average voltage (V)} = 15.6 \times T1/T$$

The output terminal of the FMP terminal is composed of the transistor, therefore there is a saturation voltage ($0.5V^{MAX}$). When using in the analogue by the filter processing the pulse voltage, it should be make a 0V adjustment by external equipment.

- ◆ This function sets the average voltage of pulse output to terminal FMP.

F 3 4 F M P V - A D J

Setting range

- 0%: The pulse rate varies depending on the monitor amount of the monitor item selected in F35. (The maximum value is the value set in F33. The pulse duty is fixed at 50%.)
- 1 to 200%: Pulse rate is fixed at 2,670 p/s. The average voltage of the monitor item selected in F35 when the monitor amount is 100% is adjusted in the 1 to 200% range (1% steps). (The pulse duty varies.)

- ◆ This function selects the monitor item to be output to terminal FMP.

F 3 5 F M P F U N C

The set value and monitor items are the same as those of F31.

F36 30Ry operation mode

- ◆ This function specifies whether to activate (excite) the alarm output relay (30Ry) for any fault at normal or alarm status.

F 3 6 3 0 R Y M O D E

Set value	Operation
0	At normal 30A - 30C: OFF, 30B - 30C: ON At abnormal 30A - 30C: ON, 30B - 30C: OFF
1	At normal 30A - 30C: ON, 30B - 30C: OFF At abnormal 30A - 30C: OFF, 30B - 30C: ON

- ◆ When the set value is 1, contacts 30A and 30C are connected when the inverter control voltage is established (about one second after power on).
- ◆ When the power is off, contacts 30A and 30C are OFF; 30B and 30C are ON.

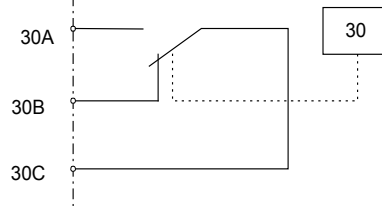

F40 Torque limiter 1 (driving)

F41 Torque limiter 1 (braking)

- ◆ The torque limit operation calculates motor torque from the output voltage, current and the primary resistance value of the motor, and controls the frequency so the calculated value does not exceed the limit. This operation enables the inverter to continue operation under the limit even if a sudden change in load torque occurs.
- ◆ Select limit values for the driving torque and braking torque.
- ◆ When this function is activated, acceleration and deceleration operation times are longer than the set values.
- ◆ The motor tuning (P04 / A13) should be set to "2" for this function is valid.
- ◆ The increase frequency upper bound during torque limit operation is set by function code : U01.
- ◆ When the setting value is selected "0" (prevent OU trip), the operation mode is selected by function code : U60. The details are referred to the functions : U01, U60.

Related functions:
U01, U60

F 4 0 D R V T R Q 1
F 4 1 B R K T R Q 1

Function	Setting range	Operation
Torque limit (driving)	G11S:20% to 200% P11S:20% to 150%	The torque is limited to the set value.
	999	Torque limiting inactive
Torque limit (braking)	G11S:20% to 200% P11S:20% to 150%	The torque is limited to the set value.
	0	Prevents OU trip due to power regeneration effect automatically.
	999	Torque limiting inactive

WARNING

When the torque limit function is selected, an operation may not match the set acceleration and deceleration time or set speed. The machine should be so designed that safety is ensured even when operation does not match set values.

Accident may result.

WARNING

The frequency may be stagnated / not decelerate when using the automatically OU trip prevention and set the frequency limit(Low) to the setting frequency or less.

Accident may result.

F42

Torque vector control 1

- ◆ This is a function for motor 1.
- ◆ To obtain the motor torque most efficiently, the torque vector control calculates torque according to load, to adjust the voltage and current vectors to optimum values based on the calculated value.

Related functions:
P01, P09

F 4 2 T R Q V E C T O R 1

Set value	Operation
0	Inactive
1	Active

- ◆ When 1 (Active) is set, the set values of the following functions differ from the written values:
 - ① F09 Torque boost 1
Automatically set to 0.0 (automatic torque boosting).
 - ② P09 Slip compensation amount Slip compensation is automatically activated.
When 0.0 is set, the amount of slip compensation for the FUJI standard 3-phase motor is applied. Otherwise, the written value is applied.
- ◆ Use the torque vector control function under the following conditions:
 - ① There must be only one motor.
Connection of two or more motors makes accurate control difficult.
 - ② The function data (rated current P03, no-load current P06, %R1 P07, and %X P08) of motor 1 must be correct.
When the standard FUJI 3-phase motor is used, setting the capacity (function P02) ensures entry of the above data. An auto tuning operation should be performed for other motors.
 - ③ The rated current of the motor must not be significantly less than the rated current of the inverter. A motor two ranks lower in capacity than the nominal applied motor for the inverter should be used at the smallest (depending on the model).
 - ④ To prevent leakage current and ensure accurate control, the length of the cable between the inverter and motor should not exceed 164ft(50m).
 - ⑤ When a reactor is connected between the inverter and the motor and the impedance of the wiring cannot be disregarded, use P04, "Auto tuning," to rewrite data.

If these conditions are not satisfied, set 0 (Inactive).

E: Extension Terminal Functions

E01

X1 Terminal function

5

5

E09

X9 Terminal function

◆ Each function of digital input terminals X1 to X9 can be set as codes.

E	0	1	X	1	F	U	N	C				
E	0	2	X	2	F	U	N	C				
E	0	3	X	3	F	U	N	C				
E	0	4	X	4	F	U	N	C				
E	0	5	X	5	F	U	N	C				
E	0	6	X	6	F	U	N	C				
E	0	7	X	7	F	U	N	C				
E	0	8	X	8	F	U	N	C				
E	0	9	X	9	F	U	N	C				

Set value	Function
0,1,2,3	Multistep frequency selection (1 to 15 steps) [SS1],[SS2],[SS4],[SS8]
4,5	Acceleration and deceleration time selection (3 steps) [RT1],[RT2]
6	Self-hold selection [HLD]
7	Coast-to-stop command [BX]
8	Alarm reset [RST]
9	External alarm [THR]
10	Jogging [JOG]
11	Frequency setting 2/frequency setting 1 [Hz2/Hz1]
12	Motor 2/motor 1 [M2/M1]
13	DC injection brake command [DCBRK]
14	Torque limit 2/torque limit 1 [TL2/TL1]
15	Switching operation from line to inverter (50Hz) [SW50]
16	Switching operation from line to inverter (60Hz) [SW60]
17	UP command [UP]
18	DOWN command [DOWN]
19	Edit permission command (data change permission) [WE-KP]
20	PID control cancellation [Hz/PID]
21	Forward/inverse switching (terminals 12 and C1) [IVS]
22	Interlock (52-2) [IL]
23	Torque control cancellation [Hz/TRQ]
24	Link operation selection (Standard:RS-485, Option: BUS) [LE]
25	Universal DI [U-DI]
26	Start characteristics selection [STM]
27	PG-SY enable (Option) [PG/Hz]
28	Synchronization command (Option) [SYC]
29	Zero speed command with PG option [ZERO]
30	Forced stop command [STOP1]
31	Forced stop command with Deceleration time 4 [STOP2]
32	Pre-exiting command with PG option [EXITE]
33	Line speed control Cancellation [Hz/LSC]
34	Line speed frequency memory [LSC-HLD]
35	Frequency setting 1 / Frequency setting 2 [Hz1/Hz2]

Note: Data numbers which are not set in the functions from E01 to E09, are assumed to be inactive.

Multistep frequency selection [SS1][SS2][SS4][SS8]

The frequency can be switched to a preset frequency in function codes C05 to C19 by switching the external digital input signal. Assign values 0 to 3 to the target digital input terminal. The combination of input signals determines the frequency.

Combination of set value input signals				Frequency selected
3 [SS8]	2 [SS4]	1 [SS2]	0 [SS1]	
off	off	off	off	Assigned by F01 or C30
off	off	off	on	C05 MULTI Hz-1
off	off	on	off	C06 MULTI Hz-2
off	off	on	on	C07 MULTI Hz-3
off	on	off	off	C08 MULTI Hz-4
off	on	off	on	C09 MULTI Hz-5
off	on	on	off	C10 MULTI Hz-6
off	on	on	on	C11 MULTI Hz-7
on	off	off	off	C12 MULTI Hz-8
on	off	off	on	C13 MULTI Hz-9
on	off	on	off	C14 MULTI Hz-10
on	off	on	on	C15 MULTI Hz-11
on	on	off	off	C16 MULTI Hz-12
on	on	off	on	C17 MULTI Hz-13
on	on	on	off	C18 MULTI Hz-14
on	on	on	on	C19 MULTI Hz-15

**Related function
C05 to C19**

Setting range
G11S:0.00 to 400.00Hz
P11S:0.00 to 120.00Hz

Acceleration and deceleration time selection [RT1][RT2]

The acceleration and deceleration time can be switched to a preset time in function codes E10 to E15 by switching the external digital input signal. Assign values 4 and 5 to the target digital input terminal. The combination of input signals determines the acceleration and deceleration times.

Combination of set value input signals		Acceleration and deceleration times selected
5 [RT2]	4 [RT1]	
off	off	F07 ACC TIME1 F08 DEC TIME1
off	on	E10 ACC TIME2 E11 DEC TIME2
on	off	E12 ACC TIME3 E13 DEC TIME3
on	on	E14 ACC TIME4 E15 DEC TIME4

**Related function
F07~F08
E10~E15**

Setting range
0.01 to 3600s

3-wire operation stop command [HLD]

This selection is used for 3-wire operation. The FWD or REV signal is self-held when [HLD] is on, and the self-hold is cleared when [HLD] is turned off. To use this [HLD] terminal function, assign 6 to the target digital input terminal.

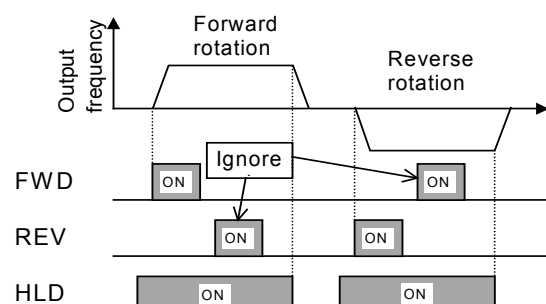

Coast-to-stop command [BX]

When BX and P24 are connected, inverter output is cut off immediately and the motor starts to coast-to-stop. An alarm signal is neither output nor self-held. If BX and P24 are disconnected when the operation command (FWD or REV) is on, operation starts at the start frequency. To use this BX terminal function, assign value "7" to the target digital input terminal.

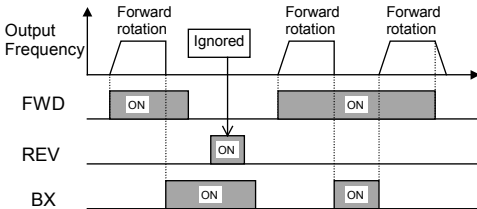

Alarm reset [RST]

When an inverter trip occurs, connecting RST and P24 clears the alarm output (for any fault); disconnecting them clears trip indication and restarts operation. To use this RST terminal function, assign value "8" to the target digital input terminal.

External fault [THR]

Disconnecting THR and P24 during operation cuts off inverter output (i.e., motor starts to coast-to-stop) and outputs alarm OH2, which is self-held internally and cleared by RST input. This function is used to protect an external brake resistor and other components from overheating. To use this THR terminal function, assign value "9" to the target digital input terminal. ON input is assumed when this terminal function is not set.

Jogging operation[JOG]

This function is used for jogging (inching) operation to position a work piece. When JOG and P24 are connected, the operation is performed with the jogging frequency set in function code C20 while the operation command (FWD-P24 or REV-P24) is on. To use this JOG terminal function, assign value "10" to the target digital input terminal.

Note: It is possible to change to the JOG operation by keypad panel when keypad panel operation.

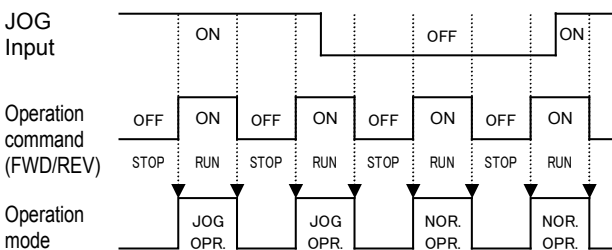

⚠️ WARNING

- When the JOG command and operation command (FWD/REV) are input at the same time, it can NOT be changed to the JOG operation. It operates with setting frequency.
 - When the JOG operation is used, it should be input the operation command after input the JOG command during the inverter is STOP.
 - When the JOG command and operation command are input at the same time, the JOG command is assigned to the "Multistep frequency selection (SS1 to SS8)" and used it.
 - The inverter can NOT be stopped and JOG operation is continued even JOG command is OFF during JOG operation. The inverter is deceleration to a stop if the operation command is OFF.
- Accident may result.**

Frequency setting 2/frequency setting 1 [Hz1/Hz2]

This function switches the frequency setting method set in function codes F01 and C30 by an external digital input signal.

Set value input signal	Frequency setting method selected
11	
off	F01 FREQ CMD1
on	C30 FREQ CMD2

Note: It can not be used with set value "35" simultaneously. When the set value "11" and "35" are selected, "Er6" is displayed.

Motor 2/motor 1 [M1/M2]

This function switches motor constants using an external digital input signal.

This input is effective only when the operation command to the inverter is off and operation has stopped and does not apply to the operation at 0Hz.

Set value input signal	Motor selected	Related function A01~A18
12		
off	Motor 1	
on	Motor 2	

DC brake command [DCBRK]

When the external digital input signal is on, DC injection braking starts when the inverter's output frequency drops below the frequency preset in function code F20 after the operation command goes off. (The operation command goes off when the **STOP** key is pressed at keypad panel operation and when both terminals FWD and REV go on or off at terminal block operation.) The DC injection braking continues while the digital input signal is on. In this case, the longer time of the following is selected:

- The time set in function code F22.
- The time which the input signal is set on.

Set value input signal	Operation selected
13	
off	No DC injection brake command is given.
on	A DC injection brake command is given.

Torque limit 2/torque limit 1 [TL2/TL1]

This function switches the torque limit value set in function codes F40 and F41, and E16 and E17 by an external digital input signal.

Set value input signal	Torque limit value selected	Related function F40~F41 E16~E17
14		
off	F40 DRV TRQ1 F41 BRK TRQ1	Setting range DRV 20 to 200% ,999 BRK 0, 20 to 200% ,999
on	E16 DRV TRQ2 E17 BRK TRQ2	

Switching operation between line and inverter (50Hz) [SW50]

Motor operation can be switched from 50Hz commercial power operation to inverter operation without stopping the motor by switching the external digital input signal.

Set value input signal	Function
15	
off→on	Inverter operation to line operation (50Hz)
on→off	Line operation to inverter operation (50Hz)

Switching operation between line and inverter (60Hz) [SW60]

Motor operation can be switched from 60Hz commercial power operation to inverter operation without stopping the motor by switching the external digital input signal.

Set value input signal	Function
16	
off→on	Inverter operation to line operation (60Hz)
on→off	Line operation to inverter operation (60Hz)

◆When the digital input signal goes off, 50 or 60 Hz is output according to the set value input signal after the restart waiting time following a momentary power failure (function code H13). The motor is then directed to inverter operation.

! WARNING

- After the LU(Low Voltage) trip is occurred and reset it, the inverter will automatically restart because the operation command is kept by internal sequence.
Accident may result.

UP command [UP]/DOWN command [DOWN]

When an operation command is input (on), the output frequency can be increased or decreased by an external digital input signal.

The change ranges from 0 to maximum frequency. Operation in the opposite direction of the operation command is not allowed.

Related function
F01, C30

Related function
E01~E09
(set value: 11, 35)

Combination of set value input signals		Function selected (when operation command is on)
18	17	
off	off	Holds the output frequency.
off	on	Increases the output frequency according to the acceleration time.
on	off	Decreases the output frequency according to the deceleration time.
on	on	Holds the output frequency.

There are the two types of UP/DOWN operations as shown below. Set the desired type by setting the frequency (F01 or C30).

◆The data "8: UP/DOWN 1" is valid only when the Motor 2 is selected.

Frequency setting (F01 or C30)	Initial value at power input on	Operation command reentry during deceleration
8 (UP/DOWN1)	0Hz	Operates at the frequency at reentry. Frequency FWD ON OFF (REV) OFF
9 (UP/DOWN2)	Previous frequency	Returns to the frequency before deceleration. Frequency FWD ON OFF (REV) OFF

Write enable for KEYPAD [WE-KP]

This function allows the data to be changed only when an external signal is being input, thereby making it difficult to change the data.

19	Function selected
off	Inhibit data changes.
on	Allow data changes.

Note:

If a terminal is set to value 19, the data becomes unable to be changed. To change the data, turn on the terminal and change the terminal setting to another number.

PID control cancel [Hz/PID]

The PID control can be disabled by an external digital input signal.

Set value input signal	Function selected	Related function H20~H25
20		
off	Enable PID control.	
on	Disable PID control (frequency setting from keypad panel).	

Inverse mode changeover [IVS]

The analog input (terminals 12 and C1) can be switched between forward and inverse operations by an external digital input signal.

Set value input signal	Function selected	Related function
21		F01, C30
off	Forward operation when forward operation is set and vice versa	
on	Inverse operation when forward operation is set and vice versa	

◆ This function is invalid when the PID control is selected (H20: 1 or 2).

Interlock signal (52-2) [IL]

When a contactor is installed on the output side of the inverter, the contactor opens at the time of a momentary power failure, which hinders the reduction of the DC circuit voltage and may prevent the detection of a power failure and the correct restart operation when power is recovered. The restart operation at momentary power failure can be performed effectively with power failure information provided by an external digital input signal.

Set value input signal	Function selected	Related function
22		F14
off	No momentary power failure detection operation by digital input	
on	Momentary power failure detection operation by digital input	

Torque control cancel [Hz/TRQ]

When function code H18 (torque control function selection) is set to be active (value 1 or 2), this operation can be canceled externally. Assign value "23" to the target digital input terminal and switch between operation and no operation in this input signal state.

Set value input signal	Function selected	Related function
23		H18
off	Torque control function active The input voltage to terminal 12 is the torque command value.	
on	Torque control function inactive The input voltage to terminal 12 is the frequency command value. PID feedback amount when PID control operation is selected (H20 = 1 or 2).	

! WARNING

- The motor speed may be changed quickly when the "Torque control cancel" is changed to ON or OFF because of changing the control.

Accident may result.

Link enable (RS-485 standard, BUS) [LE]

Frequency and operation commands from the link can be enabled or disabled by switching the external digital input signal. Select the command source in H30, "Link function." Assign value "24" to the target digital input terminal and enable or disable commands in this input signal state.

Set value input signal	Function selected	Related function
24		H30
off	Link command disabled.	
on	Link command enabled.	

Universal DI (U-DI)

Assigning value "25" to a digital input terminal renders the terminal a universal DI terminal. The ON/OFF state of signal input to this terminal can be checked through the RS-485 and BUS option.

This input terminal is only used to check for an incoming input signal through communication and does not affect inverter operation.

Pick up start mode [STM]

The start characteristics function (pick-up mode) in function code H09 can be enabled or disabled by switching the external digital input signal. Assign value "26" to the target digital input terminal and enable or disable the function in this input signal state.

Set value input signal	Function selected	Related function
26		H09
off	Start characteristic function disabled	
on	Start characteristic function enabled	

PG-SY enable (Option) [PG/Hz]

Zero speed command with PG option [ZERO]

Pre-exiting command with PG option [EXITE]

These functions are used for PG-Option or SY-Option card. Refer to each instruction manual.

Forced stop command with Deceleration [STOP1]

Forced stop command with Deceleration time 4 [STOP2]

Normally this terminal should be "ON", when this terminal goes off during motor running, the motor decelerates to stop, and outputs alarm "Er6". When the inverter is stop by STOP1/STOP2 signal, the signal should be kept on 4ms or longer.

In case of terminal [STOP2], the deceleration time is determined by E15(DEC TIME4).

This function is prioritized under any operation (Terminal. Keypad, Communication...operation). However when the torque limiter/regeneration avoidance at deceleration is selected, the time which is set by deceleration time may be longer.

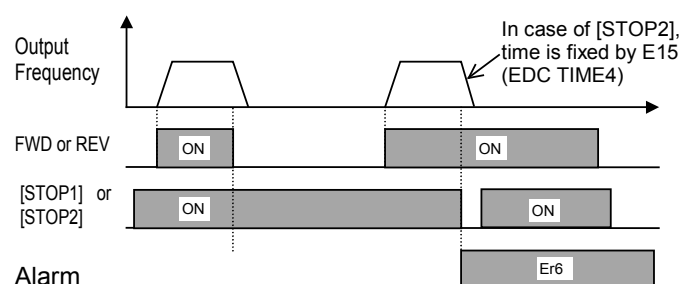

Line speed control Cancellation [Hz/LSC]

Line speed frequency memory [LSC-HLD]

- ◆ These functions are used for OPC-G11S-PG / PG2 and PGA. Refer to each instruction manual.

Frequency setting 1 / Frequency setting 2 [Hz1/Hz2]

- ◆ This function switches the frequency setting method set in function codes F01 and C30 by an external digital input signal. This is the reverse-logic of setting value "11"(Frequency setting 2/Frequency setting 1 [Hz2/Hz1]).

**Related functions
E01 to E09
(Set values:14)**

E 1 0	A	C	C	T	I	M	E	2	
E 1 1	D	E	C	T	I	M	E	2	
E 1 2	A	C	C	T	I	M	E	3	
E 1 3	D	E	C	T	I	M	E	3	
E 1 4	A	C	C	T	I	M	E	4	
E 1 5	D	E	C	T	I	M	E	4	

- ◆ Example: When 4 and 5 are set to terminals X2 and X3:

Set value input signal	Frequency setting method selected
35	
off	C30 FREQ CMD2
on	F01 FREQ CMD1

Note: It can not be used with set value "11" simultaneously. When the set value "11" and "35" are selected, "Er6" is displayed.

Settings when shipped from the factory

Digital input	Setting at factory shipment	
	Set value	Description
Terminal X1	0	Multistep frequency selection [SS1]
Terminal X2	1	Multistep frequency selection [SS2]
Terminal X3	2	Multistep frequency selection [SS4]
Terminal X4	3	Multistep frequency selection [SS8]
Terminal X5	4	Acceleration and deceleration selection [RT1]
Terminal X6	5	Acceleration and deceleration selection [RT2]
Terminal X7	6	Self-hold selection [HLD]
Terminal X8	7	Coast-to-stop command [BX]
Terminal X9	8	Alarm reset [RST]

E10	Acceleration time 2
E11	Deceleration time 2
E12	Acceleration time 3
E13	Deceleration time 3
E14	Acceleration time 4
E15	Deceleration time 4

- ◆ Acceleration time 1 (F07) and deceleration time 1 (F08) as well as three other types of acceleration and deceleration time can be selected.
- ◆ The operation and setting ranges are the same as those of acceleration time 1 and deceleration time 1. See explanations for F07 and F08.
- ◆ For switching acceleration and deceleration times, select any two terminals from terminal X1 (function selection) in E01 to terminal X9 (function selection) in E09 as switching signal input terminals. Set "4" (acceleration and deceleration time 1) and "5" (acceleration and deceleration time 2) to the selected terminals and input a signal to each terminal to switch acceleration and deceleration times. Switching is possible during acceleration, deceleration, or constant-speed operation.

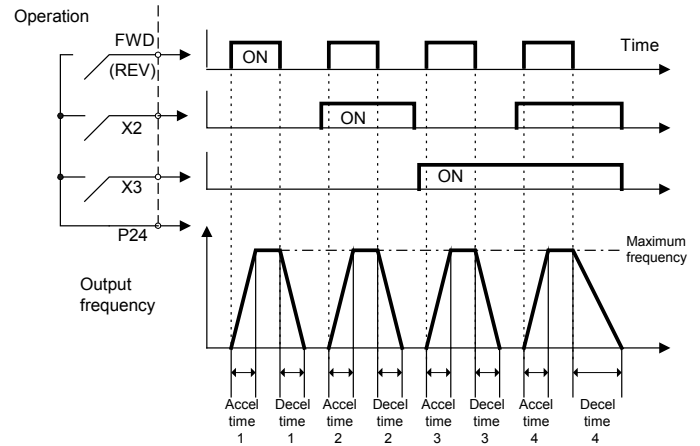

E16 Torque limiter 2 (driving)

E17 Torque limiter 2 (braking)

- ◆ This function is used to switch the torque limit level set in F40 and F41 by an external control signal. Input an external signal by selecting any of the control input terminals (X1 to X9) as torque limit 2/torque limit 1 (value 14) in E01 to E09.
- ◆ The motor tuning (P04 / A13) should be set to "2" for this function is valid.
- ◆ Maximum compensation frequency during braking torque limit is set by U01.

**Related functions
U01
U60**

- ◆ The operation mode is set by U60 when the setting value is "0%: Regeneration avoidance at deceleration". The detail is referred to the U01, U60.

**Related functions
E01~E09
(Set value: 14)**

E 1 6	D	R	V	T	R	Q	2	
E 1 7	B	R	K	T	R	Q	2	

E20 Y1 terminal function

5 5

E24 Y5A and Y5C terminal function

◆ Some control and monitor signals can be selected and output from terminals [Y1] to [Y5]. Terminals [Y1] to [Y4] use transistor output; terminals [Y5A] and [Y5C] use relay contacts.

E	2	0	Y	1		F	U	N	C				
E	2	1	Y	2		F	U	N	C				
E	2	2	Y	3		F	U	N	C				
E	2	3	Y	4		F	U	N	C				
E	2	4	Y	5		F	U	N	C				

Set value	Output signal
0	Operating [RUN]
1	Frequency arrival [FAR]
2	Frequency detection [FDT1]
3	Stopping due to undervoltage [LV]
4	Torque polarity detection [B/D]
5	Torque limiting [TL]
6	Restarting after momentary power failure [IPF]
7	Overload early warning [OL1]
8	During keypad panel operation [KP]
9	Inverter stopping [STP]
10	Ready for operation [RDY]
11	Operation switching between line and inverter [SW88]
12	Operation switching between line and inverter [SW52-2]
13	Operation switching between line and inverter [SW52-1]
14	Motor 2 switching [SWM2]
15	Terminal AX function [AX]
16	Pattern operation stage change [TU]
17	Pattern operation cycle operation completed [TO]
18	Pattern operation stage number [STG1]
19	Pattern operation stage number [STG2]
20	Pattern operation stage number [STG4]
21	Alarm detail [AL1]
22	Alarm detail [AL2]
23	Alarm detail [AL4]
24	Alarm detail [AL8]
25	Cooling fan operating [FAN]
26	Retry function operating [TRY]
27	Universal DO [U-DO] *
28	Heat sink overheat early warning [OH]
29	Synchronization completed by synchronous operation card [SY] *
30	Life expectancy detection signal [LIFE]
31	2nd Freq. level detection [FDT2]
32	2nd OL level detection [OL2]
33	Terminal C1 off signal [C1OFF]
34	Speed existence signal [DNZS] *
35	Speed agreement signal [DSAG] *
36	PG error signal [PG-ABN] *
37	Torque limiting (Signal with delay) [TL2]

Note: For output signals marked "*" are used for RS-485 communication, OPC-G11S-PG / PG2, PGA or OPC-G11S-SY. Refer to each instruction manual.

Inverter running [RUN]

"Running" means that the inverter is outputting a frequency. "RUN" signal is output as when there is output speed (frequency). When the DC injection brake function is active, "RUN" signal is off.

Frequency equivalence signal [FAR]

See the explanation of function code E30 (frequency arrival [detection width]).

Frequency level detection [FDT1]

See the explanation of function codes E31 and E32 (frequency detection).

Undervoltage detection signal [LV]

If the undervoltage protective function activates, i.e. when the main circuit DC voltage falls below the undervoltage detection level, an ON signal is output. The signal goes off when the voltage recovers and increases above the detection level. The ON signal is retained while the undervoltage protective function is activating. Undervoltage detection level: 230V series: 200V, 460V series: 400V.

Torque polarity [B/D]

This function determines the torque polarity calculated in the inverter and outputs a signal indicating driving or braking torque. An OFF signal is output for driving torque; an ON signal is output for braking torque.

Torque limiting [TL]

When the torque limiting activates, the stall prevention function is automatically activated to change the output frequency. The torque limiting signal is output to lighten the load, and also used to display overload conditions on the monitor device. This ON signal is output during the current or torque is limited or power regeneration is prevented.

Auto-restarting [IPF]

Following a momentary power failure, this function reports the start of the restart mode, the occurrence of an automatic pull-in, and the completion of the recovery operation.

Following a momentary power failure, an ON signal is output when power is recovered and a synchronization (pull-in) operation is performed. The signal goes off when the frequency (before power failure) is recovered. For 0Hz restart at power recovery, no signal is output because synchronization ends when power is recovered. The frequency is not recovered to the frequency before the power failure occurrence.

Overload early warning [OL1]

Before the motor stops by the trip operation of an electronic thermal O/L relay, this function outputs an ON signal when the load reaches the overload early warning level.

Either the electronic thermal O/L relay early warning or output current overload early warning can be selected. For setting procedure, see "E33 Overload early warning (operation selection)", and "E34 Overload early warning (operation level)."

Note: This function is effective for motor 1 only.

Keypad operation mode [KP]

An ON signal is output when operation command keys (**FWD**, **REV** and **STOP**) on the keypad panel can be used (i.e., 0 set in "F02 Operation") to issue operation and stop commands.

This signal is OFF when the function H30(Serial link) is set to communication side.

Inverter stopping [STOP]

This function outputs an inverted signal to Running (RUN) to indicate zero speed. An ON signal is output when the DC injection brake function is operating.

Ready output [RDY]

This function outputs an ON signal when the inverter is ready to operate. The inverter is ready to operate when the main circuit and control circuit power is established and the inverter protective function is not activating. About one second is required from power-on to ready for operation in normal condition.

Line/Inv changeover [SW88] [SW52-2] [SW52-1]

To perform switching operation between the line and the inverter, the sequence prepared in the inverter can be used to select and output signals for opening and closing the magnetic contactors connected to the inverter. As the operation is complex, refer to technical documentation for the FRENIC5000G11S series when using this function.

As the sequence will operate automatically when SW88 or SW52-2 is selected, do not select when not using the sequence.

Motor 2 /Motor 1 [SWM2]

When a signal for switching to motor 2 is input from the terminal selected by terminals [X1] to [X9], this function selects and outputs the signal for switching the magnetic contactor for the motor. As this switching signal is not output during running including when the DC injection braking function is operating, a signal must be re-input after output stops.

Auxiliary terminal [AX]

When an operation (forward or reverse) command is entered, this function outputs an ON signal. When a stop command is entered, the signal goes off after inverter output stops. When a coast-to-stop command is entered and the inverter protective function operates, the signal goes off immediately.

Time-up signal for pattern operation [TU]

When the pattern operation stage changes, this function outputs a one-shot (100ms) ON signal to report a stage change.

Cycle completion signal for pattern operation [TO]

When the seven stages of a pattern operation are completed, this function outputs a one-shot (100 ms) ON signal to report the completion of all stages.

Stage No. indication for pattern operation [STG1] [STG2] [STG4]

During pattern operation, this function reports the stage (operation process) being operated.

Pattern operation stage No.	Output terminal		
	STG1	STG2	STG4
Stage 1	on	off	off
Stage 2	off	on	off
Stage 3	on	on	off
Stage 4	off	off	on
Stage 5	on	off	on
Stage 6	off	on	on
Stage 7	on	on	on

When pattern operation is not activated (i.e., no stage is selected), the terminals do not output a signal.

Alarm indication [AL1] [AL2] [AL4] [AL8]

This function reports the operating status of the inverter protective function.

Alarm detail (inverter protective function)	Output terminal			
	AL1	AL2	AL4	AL8
Overcurrent, ground fault, fuse blown	on	off	off	off
Overvoltage	off	on	off	off
Undervoltage shortage, input phase failure	on	on	off	off
Motors 1 and 2 overload	off	off	on	off
Inverter overload	on	off	on	off
Heat sink overheating, inverter inside overheating	off	on	on	off
External alarm input, braking resistor overheating	on	on	on	off
Memory error, CPU error	off	off	off	on
Keypad panel communication error, option communication error	on	off	off	on
Option error	off	on	off	on
Output wiring error	off	off	on	on
RS-485 communication error	on	off	on	on
Overspeed, PG disconnection	off	on	on	on

In normal operation terminals do not output a signal.

Fan operation signal [FAN]

When used with "H06 Cooling fan ON/OFF control," this function outputs a signal while the cooling fan is operating.

Auto-resetting [TRY]

When a value of 1 or larger is set to "H04 Retry operating," the signal is output while retry operation is activating when the inverter protective function is activated.

Universal DO [U-DO]

Assigning value "27" to a transistor output terminal renders the terminal a universal DO terminal. This function enables ON/OFF through the RS-485 and BUS option. This function serves only to turn on and off the transistor output through communication and is not related to inverter operation.

Overheat early warning [OH]

This function outputs a early warning signal when heat sink temperature is (overheat detection level - 10°C) or higher.

Life expectancy detection signal [LIFE]

- ◆ When either of data for the Life expectancy judgment of the function code:U09 to U11 reaches at the Life expectancy judgment level, the ON signal is output. However, the inverter does not do alarm. Moreover, the alarm output for any fault (30A, 30B, 30C) does not operate.

Function code	Parts of Life expectancy judgment	Life expectancy judgment level
U09	Capacitor in main circuit	85% or less of the initial value
U10	Electrolytic capacitor on PCB	61,000 hours
U11	Cooling fan	25,000 hours
U59	DC fan broken for stir internal unit up [40HP or more is corresponded.]	DC fan is broken

In the following cases, normal life judgment of the capacitor in main circuit may not be able to be performed.

1. When a power is turned off during inverter operation.
2. When cooling fan ON/OFF control is operated. (function code : H 06= 1)
3. When the power is supplied by the auxiliary input terminals (R0,T0).
4. When the option card is operated .
5. When RS-485 communication is operated .
6. When the power supply is turned off with digital input (FWD, REV, X1-X9) of a control terminal being ON.

In the case of "3", "4", "5" and "6", life judgment is enabled by adjusting the function both code:U08 and U09.

Related functions
U08~U11, U59

2nd Freq. level detection [FDT2]

This function is same as Frequency detection [FDT1], the detection level of the output frequency and hysteresis width are determined by E36 and E32.

2nd OL level early warning [OL2]

This function outputs an ON signal when the output current exceeds "E37 OL2 LEVEL" for longer than "E35 OL TIMER".

NOTE) This function is valid for both of Motor 1 and Motor 2.

Terminal C1 off signal [C1OFF]

This function outputs an ON signal when the input current of terminal C1 is less than 2mA. (When AIO option is connected, it can be detected the disconnection of C2 terminal.)

Synchronization completed by synchronous operation card [SY]

Speed agreement signal [DSAG]

PG error signal [PG-ABN]

◆The above functions are set for OPC-G11S-PG / PG2 or PGA. Refer to each instruction manual.

Torque limiting (Signal with delay) [TL2]

◆The turning on signal is output by continuing the limiting action(Torque limit operation, regeneration avoidance operation and overcurrent limiting operation) of 20ms or more.

Settings when shipped from the factory

Digital input	Setting at factory shipment	
	Set value	Description
Terminal Y1	0	Operating [RUN]
Terminal Y2	1	Frequency arrival [FAR]
Terminal Y3	2	Frequency detection [FDT]
Terminal Y4	7	Overload early warning [OL1]
Terminal Y5	10	Ready output [RDY]

E25

Y5 Ry operation mode

◆This function specifies whether to excite the Y5 relay at "ON signal mode" or "OFF signal mode".

E 2 5 Y 5 R Y M O D E

Set value	Operation
0	At "OFF signal mode" Y5A - Y5C: OFF At "ON signal mode" Y5A - Y5C: ON
1	At "OFF signal mode" Y5A - Y5C: ON At "ON signal mode" Y5A - Y5C: OFF

◆When the set value is "1", contacts Y5A and Y5C are connected when the inverter control voltage is established (about one second after power on).

E30

FAR function signal (Hysteresis)

◆This function adjusts the detection width when the output frequency is the same as the set frequency (operating frequency). The detection width can be adjusted from 0 to ± 10 Hz of the setting frequency.

E 3 0 F A R H Y S T R

Setting range: 0.0 to 10.0 Hz

When the frequency is within the detection width, an ON signal can be selected and output from terminals [Y1] to [Y5].

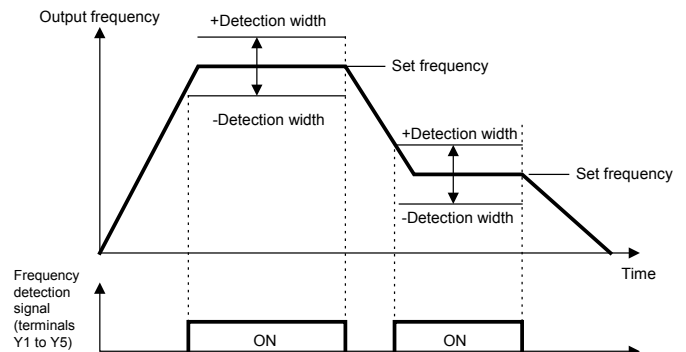

E31

FDT1 function signal (Level)

E32

FDT1 function signal (Hysteresis)

◆This function determines the operation (detection) level of the output frequency and hysteresis width for operation release. When the output frequency exceeds the set operation level, an ON signal can be selected and output from terminals [Y1] to [Y5].

E 3 1 F D T 1 L E V E L
E 3 2 F D T H Y S T R

Setting range(Operation level) : G11S: 0 to 400 Hz

P11S: 0 to 120 Hz

(Hysteresis width) : 0.0 to 30.0 Hz

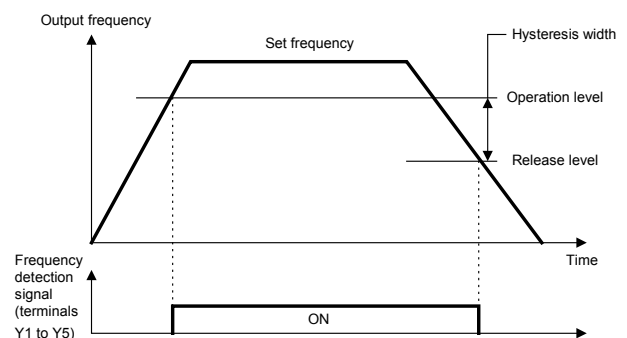

E33 OL function signal (mode select)

◆ Select one of the following two types of overload early warning: early warning by electronic thermal O/L relay function or early warning by output current.

E 3 3 O L W A R N I N G

Set value 0: Electronic thermal O/L relay
1: Output current

Set value	Function	Description
0	Electronic thermal O/L relay	Overload early warning by electronic thermal O/L relay (having inverse-time characteristics) to output current. The operation selection and thermal time constant for the inverse-time characteristics are the same as those of the electronic thermal O/L relay for motor protection (F10 and F12).
1	Output current	An overload early warning is issued when output current exceeds the set current value for the set time. The figure of OL2(E37) is referred.

◆ This function cannot be used when Motor 2 is selected.

E34 OL function signal (Level)

◆ This function determines the operation level of the electronic thermal O/L relay or output current.

E 3 4 O L 1 L E V E L

Setting range G11S: Inverter rated output current x (5 to 200%)
P11S: Inverter rated output current x (5 to 150%)

The operation release level is 90% of the set value.

◆ This function cannot be used when Motor 2 is selected.

E35 OL function signal (Timer)

E 3 5 O L 1 T I M E R

◆ This function is used when 1 (output current) is set to "E33 Overload early warning (operation selection)."

Setting range: 0.1 to 60.0 seconds

◆ Set the time from when the operation level is attained until the overload early warning function is activated.

E36 FDT2 function (Level)

◆ This function determines the operation (detection) level of output frequency for "2nd Freq. level detection [FDT2]". The hysteresis width for operation release is set by the function E32: FDT1 function signal (Hysteresis).

E 3 6 F D T 2 L E V E L

Setting range(Operation level) : G11S: 0 to 400 Hz
P11S: 0 to 120 Hz

E37 OL2 function (Level)

◆ This function determines the operation level of the output current for "2nd OL level detection [OL2]".

E 3 7 O L 2 L E V E L

Setting range G11S: Inverter rated output current x (5 to 200%)
P11S: Inverter rated output current x (5 to 150%)

The operation release level is 90% of the set value.

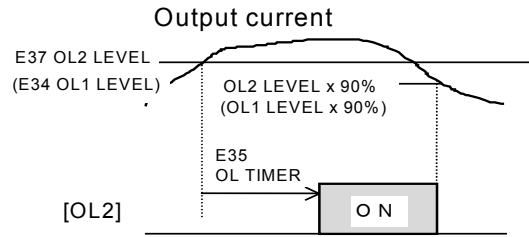

E40 Display coefficient A

E41 Display coefficient B

◆ These coefficients are conversion coefficients which are used to determine the load and line speed and the target value and feedback amount (process amount) of the PID controller displayed on the LED monitor.

E 4 0 C O E F A
E 4 1 C O E F B

Setting range

Display coefficient A: -999.00 to 0.00 to +999.00

Display coefficient B: -999.00 to 0.00 to +999.00

◆ Load and line speed

Use the display coefficient A.

Displayed value = output frequency x (0.01 to 200.00)
Although the setting range is ±999.00, the effective value range of display data is 0.01 to 200.00. Therefore, values smaller or larger than this range are limited to a minimum value of 0.01 or a maximum value of 200.00.

◆ Target value and feedback amount of PID controller
Set the maximum value of display data in E40, "Display coefficient A," and the minimum value in E41, "Display coefficient B."

Displayed value = (target value or feedback amount) x (display coefficient A - B) + B

Displayed value

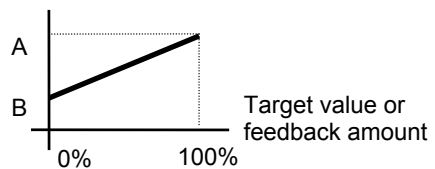

E43 LED monitor (function)

E44 LED monitor (display at stop mode)

- ◆ The data during inverter operation, during stopping, at frequency setting, and at PID setting is displayed on the LED.
- ◆ Display during running and stopping
During running, the items selected in "E43 LED monitor (display selection)," are displayed. In "E44 LED monitor (display at stopping)," specify whether to display some items out of the set values or whether to display the same items as during running.

E 4 3 L E D M N T R
E 4 4 L E D M N T R 2

Value set to E43	E44=0		E44=1	
	At stopping	During running	At stopping	During running
0	Set frequency value (Hz)	Output frequency (before slip compensation) (Hz)		
1	Set frequency value (Hz)	Output frequency (after slip compensation) (Hz)		
2	Set frequency value (Hz)			
3	Output current (A)			
4	Output voltage (command value) (V)			
5	Synchronous speed set value (r/min)	Synchronous speed (r/min)		
6	Line speed set value (m/min.)	Line speed (m/min.)		
7	Load speed set value (r/min)	Load speed (r/min)		
8	Calculated torque value (%)			
9	Output power (HP)			
10	PID target value 1 (direct input from keypad panel)			
11	PID target value 2 (input from "F02 Frequency 1")			
12	PID feedback amount			

Note: For the values 10 to 12 set to E43, the data is displayed only when selected in "H20 PID control (operation selection)."

- ◆ Display at frequency setting
When a set frequency is checked or changed by the keypad panel, the set value shown below is displayed. Select the display item by using "E43 LED monitor (display selection)." This display is not affected by "E44 LED monitor (display at stopping)."

Value set to E43	Frequency setting
0,1,2,3,4	Set value of frequency (Hz)
5	Set value of synchronous speed (r/min)
6	Set value of line speed (m/min.)
7	Set value of load speed (r/min)
8,9	Set value of frequency (Hz)
10,11,12	Set value of frequency (Hz)

Note: For the values 10 to 12 set to E43, the data is displayed only when selected in "H20 PID control (operation selection)."

E45 LCD monitor (function)

- ◆ This function selects the item to be displayed on the LCD monitor in the operation mode.

E 4 5 L C D M N T R

Set value	Display item
0	Operation status, rotating direction, operation guide
1	Output frequency (before slip compensation), output current, calculated torque value in bar graph

Set value: 0

During running

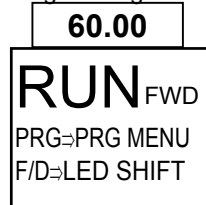

When stopping

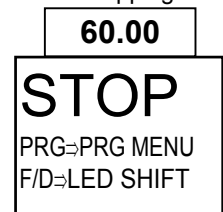

Set value: 1

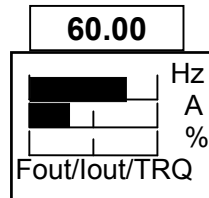

Full-scale value of bar graph

Display item	Full-scale
Output frequency	Maximum frequency
Output current	200% of inverter rated value
Calculated torque value	200% of motor rated value

Note: The scale cannot be adjusted.

E46 Language

- ◆ This function selects the language for data display on the LCD monitor.

E 4 6 L A N G U A G E

Set value	Language displayed	Set value	Language displayed
0	Japanese	3	French
1	English	4	Spanish
2	German	5	Italian

Note: English language is used for all LCD screens in this manual. For other languages, refer to the relevant instruction manual.

E47 LCD monitor (contrast)

- ◆ This function adjusts the LCD contrast. Increase the set value to raise contrast and decrease to lower contrast.

E 4 7 C O N T R A S T

Set value	0,1,2 ••••• 8,9,10
Screen	Low ←————→ High

C: Control Functions of Frequency

- C01 **Jump frequency 1**
- C02 **Jump frequency 2**
- C03 **Jump frequency 3**
- C04 **Jump frequency (Hysteresis)**

- ◆ This function makes the set frequency jump so that the inverter's output frequency does not match the mechanical resonance point of the load.
- ◆ Up to three jump points can be set.
- ◆ This function is ineffective when jump frequencies 1 to 3 are set to 0Hz.
- ◆ A jump does not occur during acceleration or deceleration. When a jump frequency setting range overlaps another range, both ranges are added to determine the actual jump area.

C 0 1	J	U	M	P	H	Z	1	
C 0 2	J	U	M	P	H	Z	2	
C 0 3	J	U	M	P	H	Z	3	

Setting range
 G11S : 0 to 400Hz
 P11S : 0 to 120Hz
 In 1Hz steps (min.)

C 0 4	J	U	M	P	H	Y	S	T	R
--------------	----------	----------	----------	----------	----------	----------	----------	----------	----------

Setting range
 0 to 30Hz
 In 1Hz steps (min.)

To avoid the resonance of the motor driving frequency to the peculiar vibration frequency of the machine, the jump frequency band can be set to the output frequency up to three point.

- ◆ During accelerating, an internal set frequency is kept constant by the lower frequency of the jump frequency band when a set frequency enters the jump frequency band. This means that the output frequency is kept constant according to an internal set frequency. When a set frequency exceeds the upper bound of the jump frequency band, an internal set frequency reaches the value of a set frequency. The output frequency accelerates up to a set frequency while passing the jump frequency band according to the acceleration time at this time.
- ◆ During decelerating, it has a relation opposite to accelerating. Refer to figure below.
- ◆ When two jump frequency bands or more come in succession mutually, the lowest and highest frequency become the lower bound and the upper bound frequency of an actual jump frequency band respectively among them. Refer to upper right figure.

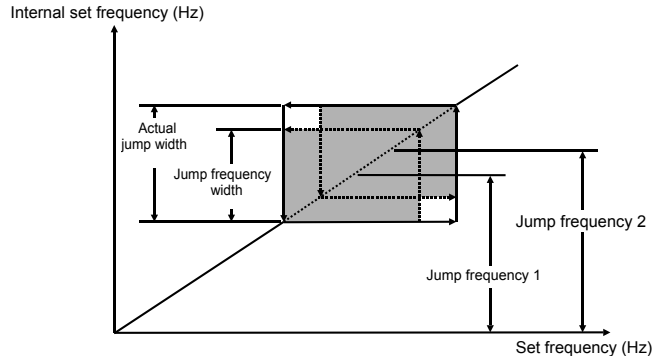
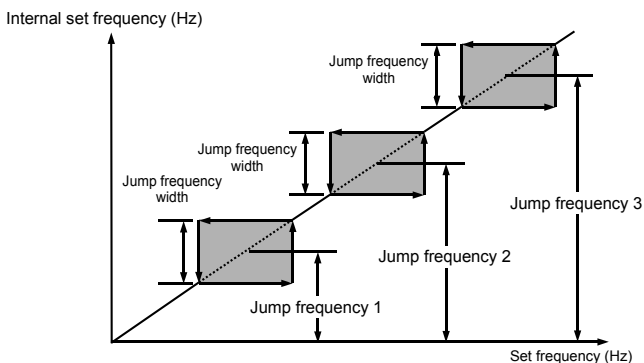

- C05 **Multistep frequency 1**

- C19 **Multistep frequency 15**

- ◆ Multistep frequencies 1 to 15 can be switched by turning on and off terminal functions SS1, SS2, SS4, and SS8. (See E01 to E09 for terminal function definitions.)
- ◆ OFF input is assumed for any undefined terminal of SS1, SS2, SS4, and SS8.

C 0 5	M	U	L	T	H	Z	- 1	Related functions E01 to E09 (Set value:0 to 3)
C 0 6	M	U	L	T	H	Z	- 2	
C 0 7	M	U	L	T	H	Z	- 3	
C 0 8	M	U	L	T	H	Z	- 4	
C 0 9	M	U	L	T	H	Z	- 5	
C 1 0	M	U	L	T	H	Z	- 6	
C 1 1	M	U	L	T	H	Z	- 7	
C 1 2	M	U	L	T	H	Z	- 8	
C 1 3	M	U	L	T	H	Z	- 9	
C 1 4	M	U	L	T	H	Z	1 0	
C 1 5	M	U	L	T	H	Z	1 1	
C 1 6	M	U	L	T	H	Z	1 2	
C 1 7	M	U	L	T	H	Z	1 3	
C 1 8	M	U	L	T	H	Z	1 4	
C 1 9	M	U	L	T	H	Z	1 5	

Setting range
 G11S: 0.00 to 400.00Hz
 P11S: 0.00 to 120.00Hz
 In 0.01Hz steps (min.)

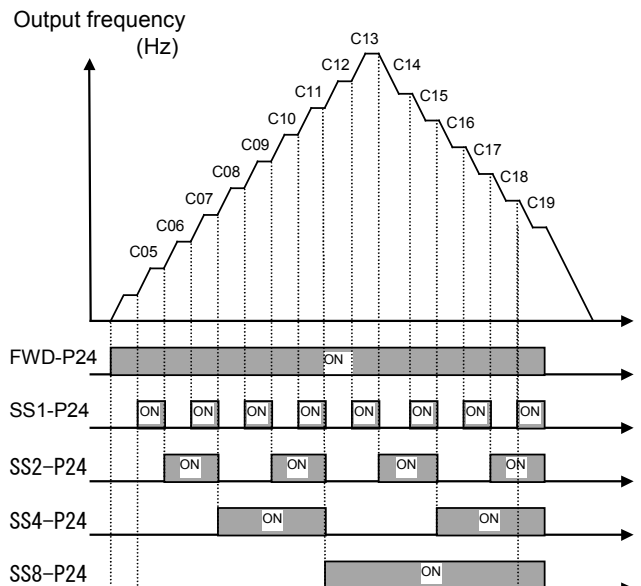

C20 JOG frequency

◆ This function sets the frequency for jogging operation of motor, which is different from the normal operation.

C 2 0 J O G H z

Setting range G11S : 0.00 to 400.00 Hz
P11S : 0.00 to 120.00 Hz

◆ Starting with the jogging frequency is combined with jogging select signal input from the keypad panel or control terminal. For details, see the explanations of "E01 Terminal X1" to "E09 Terminal X9."

C21 Pattern operation (mode select)

◆ Pattern operation is an automatic operation according to preset operation time, direction of rotation, acceleration and deceleration time, and frequency.

When using this function, set 10 (pattern operation) to "F01 Frequency setting."

The following operation patterns can be selected.

C 2 1 P A T T E R N

**Related functions
F01, C30
(Set value:10)**

Set value	Operation pattern
0	Perform a pattern operation cycle, then stop operation.
1	Perform pattern operation repeatedly. Stop operation using a stop command.
2	Perform a pattern operation cycle, then continue operation with the last frequency set.

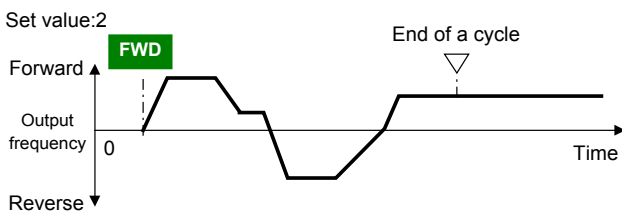
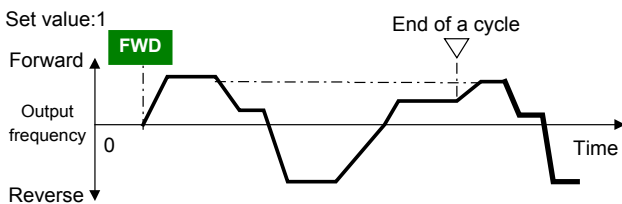
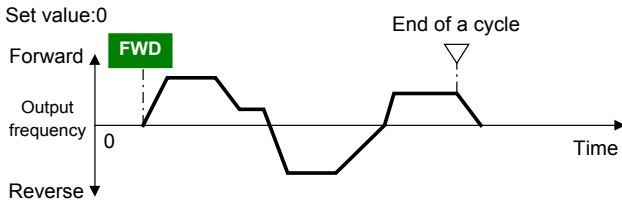

C22 Pattern operation (stage 1)

}

}

C28 Pattern operation (stage 7)

◆ Seven stages are operated in order (of function codes) according to the values set in "C22 Pattern operation (stage 1)" to "C28 Pattern operation (stage 7)." Each function sets the operation time and the rotating direction for each stage and assigns set values of the acceleration and deceleration time.

C 2 2 S T A G E	1		
C 2 3 S T A G E	2		
C 2 4 S T A G E	3		
C 2 5 S T A G E	4		
C 2 6 S T A G E	5		
C 2 7 S T A G E	6		
C 2 8 S T A G E	7		

Set or assign item	Value range
Operation time	0. 00 to 6000s
Rotation direction	F: Forward (counterclockwise) R: Reverse (clockwise)
Acceleration and deceleration time	1: Acceleration time 1 (F07), deceleration time 1 (F08) 2: Acceleration time 2 (E10), deceleration time 2 (E11) 3: Acceleration time 3 (E12), deceleration time 3 (E13) 4: Acceleration time 4 (E14), deceleration time 4 (E15)

Note: The operation time is represented by the three most significant digits, hence, can be set with only three high-order digits.

◆ Setting example

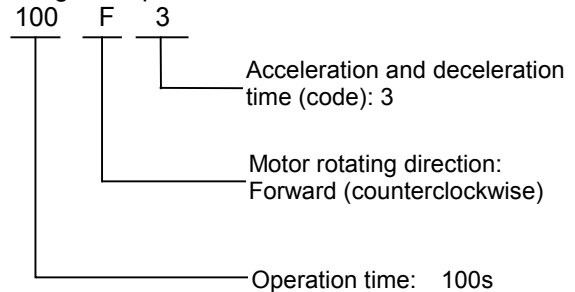

Set the operation time to 0.00 for stages not used, which are skipped in operation.

With regard to the set frequency value, the multistep frequency function is assigned as listed in the table below. Set frequencies to "C05 Multistep frequency 1," to "C11 Multistep frequency 7."

Stage No.	Operation frequency to be set
Stage 1	Multistep frequency 1 (C05)
Stage 2	Multistep frequency 2 (C06)
Stage 3	Multistep frequency 3 (C07)
Stage 4	Multistep frequency 4 (C08)
Stage 5	Multistep frequency 5 (C09)
Stage 6	Multistep frequency 6 (C10)
Stage 7	Multistep frequency 7 (C11)

◆ Pattern operation setting example

Function	Set value	Operation frequency to be set
C21 (operation selection)	1	-
C22 (stage 1)	60.0F2	Multistep frequency 1 (C05)
C23 (stage 2)	100F1	Multistep frequency 2 (C06)
C24 (stage 3)	65.5R4	Multistep frequency 3 (C07)
C25 (stage 4)	55.0R3	Multistep frequency 4 (C08)
C26 (stage 5)	50.0F2	Multistep frequency 5 (C09)
C27 (stage 6)	72.0F4	Multistep frequency 6 (C10)
C28 (stage 7)	35.0F2	Multistep frequency 7 (C11)

The following diagram shows this operation.

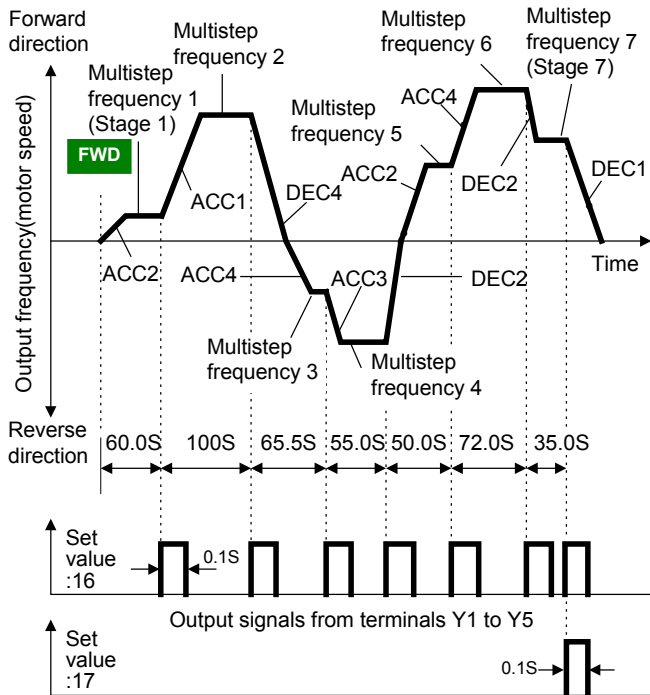

◆ Running and stopping are controlled by pressing the **FWD** and **STOP** keys and by opening and closing the control terminals.

When using the keypad panel, pressing the **FWD** key starts operation. Pressing the **STOP** key pauses stage advance. Pressing the **FWD** key again restarts operation from the stop point according to the stages. If an alarm stop occurs, press the **RESET** key to release operation of the inverter protective function, then press the **FWD** key to restart stage advance.

If required to start operation from the first stage "C22 Pattern operation (stage 1)," enter a stop command and press the **RESET** key.

If an alarm stop occurs, press the **RESET** key to release the protective function, then press the key again.

Notes:

1. The direction of rotation cannot be reversed by a command issued from the **REV** key on the keypad panel or terminal [REV]. Any reverse rotation commands entered are canceled. Select forward or reverse rotation by the data in each stage. When the control terminals are used for operation, the self-hold function of operation command also does not work. Select an alternate type switch when using.
2. At the end of a cycle, the motor decelerates-to-stop according to the value set to "F08 Deceleration time 1."

C30 Frequency command 2

◆ This function selects the frequency setting method.

Related functions
E01 to E09
(Set value:11)
F01

C 3 0 F R E Q C M D 2

For the setting method, see the explanation for F01.

C31 Bias (terminal[12])

C32 Gain (terminal[12])

◆ This function sets the Gain and Bias of the analog input (terminals [12]).

C 3 1 B I A S 1 2
C 3 2 G A I N 1 2

The setting range :

BIAS: -100 to +100%

GAIN:0.0 to 200%

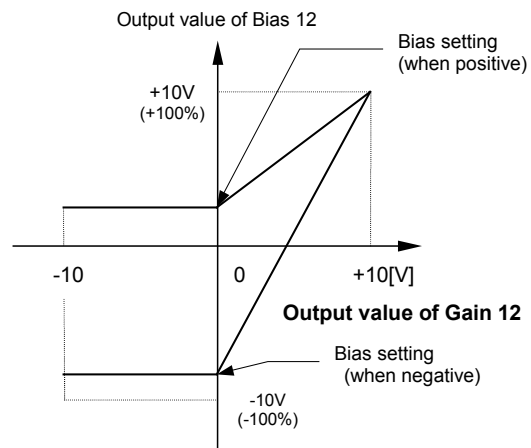
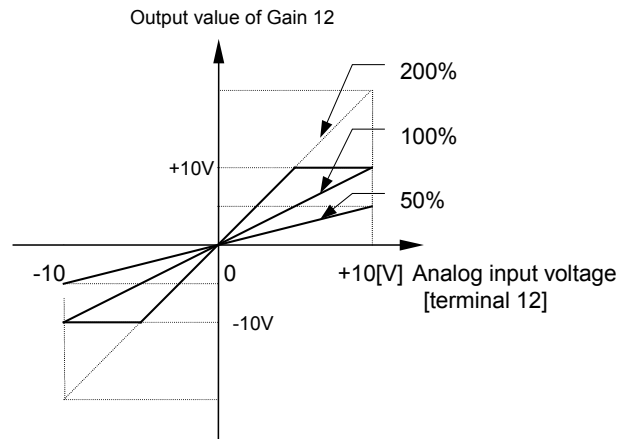

- ◆ Analog signals input from control terminal 12 or C1 may contain noise, which renders control unstable. This function adjusts the time constant of the input filter to remove the effects of noise.

C 3 3 R E F F I L T E R

Setting range: 0.00 to 5.00 seconds

- ◆ An set value too large delays control response though stabilizing control. A set value too small speeds up control response but renders control unstable.

If the optimum value is not known, change the setting when control is unstable or response is delayed.

Note:

The set value is commonly applied to terminals 12 and C1. For input of PID feedback amount, the PID control feedback filter (set in H25) is used.

Motor 1 (P: Motor Parameters)

P01 Number of motor 1 poles

- ◆ This function sets the number of poles of motor 1 to be driven. If this setting is not made, an incorrect motor speed (synchronous speed) is displayed on the LED.

P 0 1 M 1 P O L E S

Set values: 2, 4, 6, 8, 10, 12, 14

P02 Motor 1 (capacity)

- ◆ The nominal applied motor capacity is set at the factory. The setting should be changed when driving a motor with a different capacity.

P 0 2 M 1 - C A P

Set value for models with nominal applied motor of 30HP or less

: 0.01 to 60HP

Models with nominal applied motor of 40HP or more

: 0.01 to 800HP

- ◆ Set the nominal applied motor capacity listed in 9-1, "Standard Specifications." Also set a value in the range from two ranks lower to one rank higher than the nominal applied motor capacity. When a value outside this range is set, accurate control cannot be guaranteed. If a value between two nominal applied motor capacities is set, data for the lower capacity is automatically written for related function data.
- ◆ When the setting of this function is changed, the values of the following related functions are automatically set to data of the FUJI 3-phase standard motor.
 - P03 Motor 1 (rated current)
 - P06 Motor 1 (no-load current)
 - P07 Motor 1 (% R1)
 - P08 Motor 1 (% X1)

Note:

The set values for the FUJI 3-phase standard motor are 230V, 50Hz, 4 poles for the 230V series; 460V, 50Hz, 4 poles for the 460V series.

P03 Motor 1 (rated current)

- ◆ This function sets the rated current value of motor 1.

P 0 3 M 1 - I r

Setting range: 0.00 to 2,000A

P04 Motor 1 (Tuning)

- ◆ This function measures and automatically writes motor data.

P 0 4 M 1 T U N 1

Set value	Operation
0	Inactive
1	Measure the primary resistance (%R1) of the motor and leakage reactance (%X) of the base frequency when the motor is stopping and automatically write both values in P07 and P08.
2	Measure the primary resistance (%R1) of the motor and leakage reactance (%X) of the base frequency when the motor is stopping, measure the no-load current (I ₀) when the motor is running, and automatically write these values in P06, P07, and P08. Put the motor into the state unit separating from the machine for the tuning of the no-load current. In the state that the load is connected, cannot the tuning correctly. Execute the auto tuning of set value "1" after obtaining the test report etc. from the motor manufactures when not making it in the state of the motor unit, and setting P06 (no-load current) beforehand.

- ◆ Perform auto tuning when data written beforehand in "P06 No-load current," "P07 %R1," and "P08 %X," differs from actual motor data. Typical cases are listed below. Auto tuning improves control and calculation accuracy.
 - When a motor other than the FUJI standard 3-phase motor is used and accurate data is required for close control.
 - When output-side impedance cannot be ignored as when cable between the inverter and the motor is too long or when a reactor is connected.
 - When %R1 or %X is unknown as when a non-standard or special motor is used.

Tuning procedure

- Adjust the voltage and frequency according to motor characteristics. Adjust functions "F03 Maximum output frequency," "F04 Base frequency," "F05 Rated voltage," and "F06 Maximum output voltage."
- Enter untunable motor constants first. Set functions "P02 Capacity," "P03 Rated current," and "P06 No-load current," (input of no-load current not required when P04=2, for running the motor at tuning, is selected).
- When tuning the no-load current, beware of motor rotation.
- Set 1 (motor stop) or 2 (motor rotation) to function "P04 Auto tuning." Press the **FUNC DATA** key to write the set value and press the **FWD** key or **REV** key then start tuning simultaneously.
- Tuning takes several seconds to several tens of seconds (when 2 is set. As the motor accelerates up to half the base frequency according to acceleration time, is tuned for the no-load current, and decelerates according to the deceleration time, the total tuning time varies depending on set acceleration and deceleration times.)
- Press the **STOP** key after the tuning is completed.
- End of procedure.

Note1:

If REMOTE operation(F02: 1) is selected, operation signal is given from terminal [FWD] or [REV].

Note2:

Use function "A13 Motor 2 (auto tuning)," to tune motor 2. In this case, set values described in 1 and 2 above are for the function (A01 -) of motor 2.

 WARNING	When the auto tuning value is set to 2, the motor rotates at a maximum of half the base frequency. Beware of motor rotation. as injury may result.
--	--

P05 Motor 1 (On-line Tuning)

- ◆ Long-time operation affects motor temperature and motor speed. Online tuning minimizes speed changes when motor temperature changes.
- ◆ Auto tuning(P04/A13: 2) should be done to use this function.

P 0 5 M 1 T U N 2

Set value	Operation
0	Inactive
1	Active

P06 Motor 1 (no-load current)

- ◆ This function sets the no-load current (exciting current) of motor 1.

P 0 6 M 1 - I O

Setting range: 0.00 to 2,000A

P07 Motor 1 (%R1 setting)

P08 Motor 1 (%X setting)

- ◆ Write this data when using a motor other than the FUJI standard 3-phase motor and when the motor constant and the impedance between the inverter and motor are known.

P 0 7 M 1 - % R 1
P 0 8 M 1 - % X

- ◆ Calculate %R1 using the following formula:

$$\%R1 = \frac{R1 + \text{Cable } R}{V / (\sqrt{3} \cdot I)} \times 100 \quad [\%]$$

R1 : Primary coil resistance value of the motor [Ω]

Cable R : Output-side cable resistance value [Ω]

V : Rated voltage [V] I : Motor rated current [A]

- ◆ Calculate %X using the following formula:

$$\%X = \frac{X1 + X2 \cdot XM / (X2 + XM) + \text{Cable } X}{V / (\sqrt{3} \cdot I)} \times 100 \quad [\%]$$

X1 : Primary leakage reactance of the motor [Ω]

X2 : Secondary leakage reactance (converted to a primary value)of the motor [Ω]

XM : Exciting reactance of the motor [Ω]

Cable X : Output-side cable reactance [Ω]

V : Rated voltage [V] I : Motor rated current[A]

Note:

For reactance, use a value in the data written in "F04 Base frequency 1."

- ◆ When connecting a reactor or filter to the output circuit, add its value. Use value 0 for cable values that can be ignored.

P09 Slip compensation control

- ◆ Changes in load torque affect motor slippage, thus causing variations in motor speed. The slip compensation control adds a frequency (proportional to motor torque) to the inverter output frequency to minimize variations in motor speed due to torque changes.

P 0 9 S L I P C O M P 1

- ◆ Auto tuning(P04/A13: 2) should be done to use this function.

Set value: 0.00 to 15.00Hz

- ◆ Calculate the amount of slip compensation using the following formula:

Slip compensation amount

$$= \text{Base frequency} \times \frac{\text{Slippage [r/min]}}{\text{Synchronous speed [r/min]}} \quad [\text{Hz}]$$

Slippage = Synchronous speed - Rated speed

H03 Data initializing

◆ This function returns all function data changed by the customer to the factory setting data. (initialization).

H 0 3 D A T A I N I T

Set value 0: Disabled.
1: Initializing data.

◆ To perform initialization, press the **STOP** and **^** keys together to set 1, then press the **FUNC DATA** key. The set values of all functions are initialized. The set value in H03 automatically returns to 0 following the end of initialization.

H04 Auto-reset(Times)

H05 Auto-reset (Reset interval)

◆ When the inverter protective function which invokes the retry operation is activated, this function releases operation of the protective function and restarts operation without issuing an alarm or terminating output.

H 0 4 A U T O - R E S E T
H 0 5 R E S E T I N T

Set the protective function release count and waiting time from its operation startup to release.
Setting range (Count) : 0, 1 to 10
(Waiting time) : 2 to 20 seconds

To not use the retry function, set 0 to "H04 Retry (count)."

◆ Inverter protective functions that can invoke retry function.

OC1,OC2,OC3 : Overcurrent	dBH : Braking resistor overheating
OV1,OV2,OV3 : Overvoltage	OL1 : Motor 1 overload
OH1 : Heat sink overheating	OL2 : Motor 2 overload
OH3 : Inverter inside overheating	OLU : Inverter overload

◆ When the value of "H04 Retry (count)," is set from 1 to 10, an inverter run command is immediately entered following the wait time set in H05, "Retry (wait time)," and the startup of the retry operation. If the cause of the alarm has been removed at this time, the inverter starts without switching to alarm mode. If the cause of the alarm still remains, the protective function is reactivated according to the wait time set in "H05 Retry (waiting time)." This operation is repeated until the cause of the alarm is removed. The restart operation switches to alarm mode when the retry count exceeds the value set in "H04 Retry (count)."

The operation of the retry function can be monitored from terminals Y1 to Y5.

⚠ WARNING	When the retry function is selected, operation automatically restarts depending on the cause of the trip stop. (The machine should be designed to ensure safety during a restart) as accident may result.
------------------	---

When retry succeeded

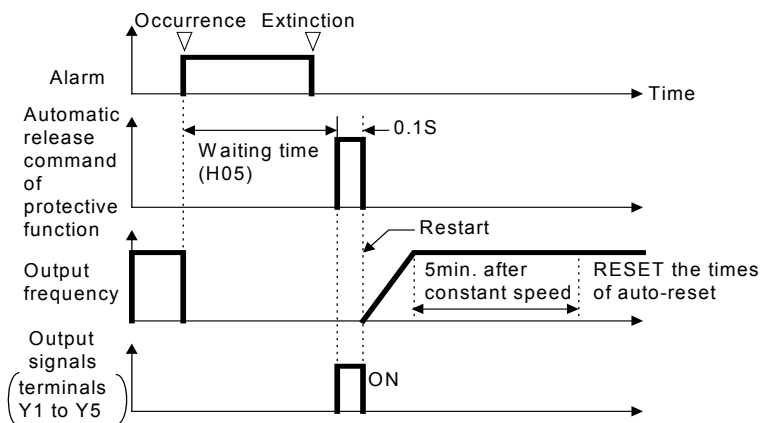

retry failed

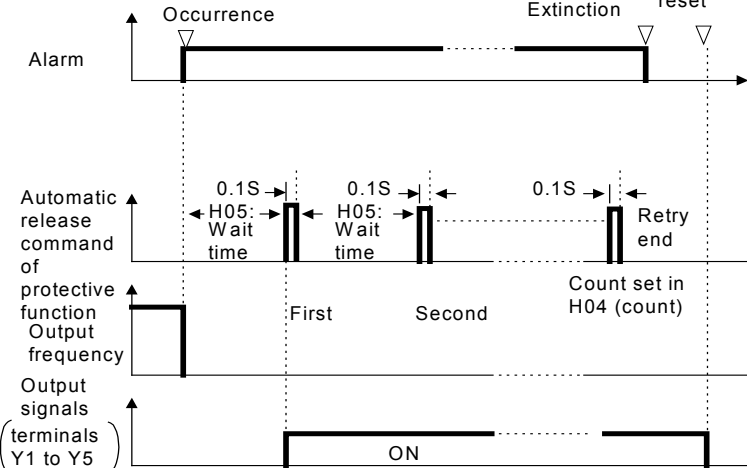

H06 Fan stop operation

◆ This function specifies whether cooling fan ON/OFF control is automatic. While power is applied to the inverter, the automatic fan control detects the temperature of the cooling fan in the inverter and turns the fan on or off.

When this control is not selected, the cooling fan rotates continually.

H 0 6 F A N S T O P

Set value 0: ON/OFF control disabled.
1: ON/OFF control enabled.

The cooling fan operating status can be monitored from terminals Y1 to Y5.

H07

ACC/DEC (Mode select) pattern

◆ This function selects the acceleration and deceleration pattern.

H 0 7 A C C P T N

- Set value 0: Inactive (linear acceleration and deceleration)
 1: S-shape acceleration and deceleration (mild)
 2: S-shape acceleration and deceleration (*)
 3: Curvilinear acceleration and deceleration

**Related functions
U02 to U05**

* The S-shape range is set by the function: U02 to U05 when the set value "2" is selected. The detail is referred to the function: U02 to U05. [S-shape acceleration and deceleration]
 This pattern reduces shock by mitigating output frequency changes at the beginning/end of acceleration and deceleration.

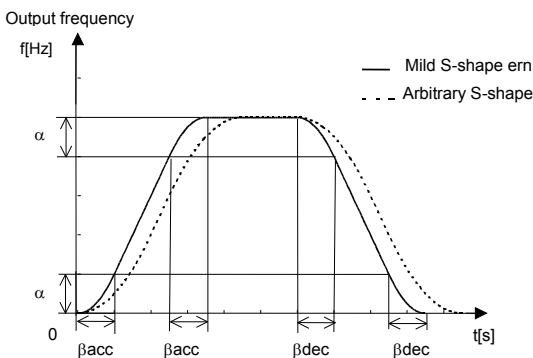

<Pattern constants>

	When 1 is selected in H07 (mild S-shape pattern)	When 2 is selected in H07 (arbitrary S-shape pattern)
Range of S-shape(α)	0.05 x max. output freq. (Hz)	(U02 to U05) x max. output freq. (Hz)
Time for S-shape at acceleration (β_{acc})	0.10 x acceleration time (s)	(U02, U03) x 2 x acceleration time (s)
Time for S-shape at deceleration (β_{dec})	0.10 x deceleration time (s)	U04, U05 x 2 x deceleration time (s)

* When acceleration and deceleration times are very long or short, acceleration and deceleration are rendered linear. It may be switched the acceleration and deceleration time during constant speed or stopping by the function "acceleration and deceleration time selection"(E01 to E09: 4, 5). The signal may be ignored switched during S-shape at acceleration. The linear deceleration time is corresponded if switched during S-shape at deceleration.

It may be switched to the S-shape operation if output frequency is reached to the setting frequency or change to acceleration control.

[Curvilinear acceleration and deceleration]

This function is used to minimize motor acceleration and deceleration times in the range that includes a constant-output range.

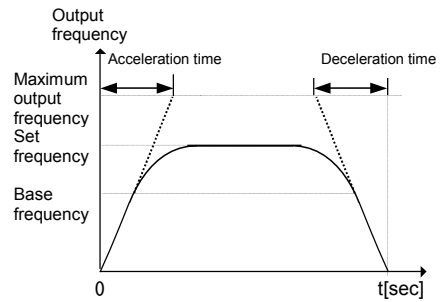

H08

Rev. phase sequence lock

◆ When accidental reversing is expected to cause a malfunction, this function can be set to prevent reversal.

H 0 8 R E V L O C K

- Set value 0: Inactive
 1: Active

When reversible operation with polarity(set value: "4" or "5") is selected in frequency command: F01, C30, the inverter operates as follows.

Operation command	0V to 10V input	-10V to 0V input
Short FWD-CM terminals or FWD : ON	The inverter operates.	The frequency display is "0.00" Hz.
Short REV-CM terminals or REV : ON	The frequency display is "0.00" Hz.	The inverter operates.

This function prevents a reversing operation resulting from a connection between the REV and P24 terminals, inadvertent activation of the **REV** key, or negative analog input from terminal 12 or V1. During this function is operating, "0.00Hz" is displayed on the LED monitor. This function cannot be prevented against H18: Torque control function. It may be reverse because of the torque signal and load.

H09 Start mode

This function smoothly starts the motor which is coasting after a momentary power failure or after the motor has been subject to external force, without stopping motor. At startup, this function detects the motor speed and outputs the corresponding frequency, thereby enabling a shock-free motor startup. Although the normal startup method is used, when the coasting speed of the motor is 120 Hz or more as an inverter frequency, when the value set to "F03 Maximum frequency," exceeds the value set to "F15 Frequency limiter (upper limit)." and when the coasting speed is less than 5 Hz as an inverter frequency.

H 0 9 S T A R T M O D E

Set value 0,1,2

Set value	STM	Restart after a momentary power failure or Line-to-inverter switching	Other operation
0	OFF / not selected	Inactive (normal starting)	
1		Active (smoothly starting)	Inactive
2		Active	
any value	ON	Active	

STM: Start characteristics selection signal(E01 to E09: 26)
NOTE:

- 1: Automatically restart when overcurrent or overvoltage is detected during smoothly starts.
- 2: The coasting speed is used 100 Hz or less as an inverter frequency.
- 3: When H09:2 or STM:ON, it needs the time more than normal start even the motor is STOP because the motor speed is detected on ALL situation. And it may be rotated the motor when the load is too small.
- 4: Auto tuning(P04/A13: 2) should be done to use this function.
- 5: When the used motor slippage is too differ from FUJI motor, the "Slip compensation control (P09, A18)" should be set. The characteristics may not be satisfied.
- ◆When the operation above is to be problem, this function is not used (inactive).
- ◆This function may not be satisfied the characteristics because of the load condition, motor constant, operating frequency, coasting speed, wire length, momentary power failure time or external factor.

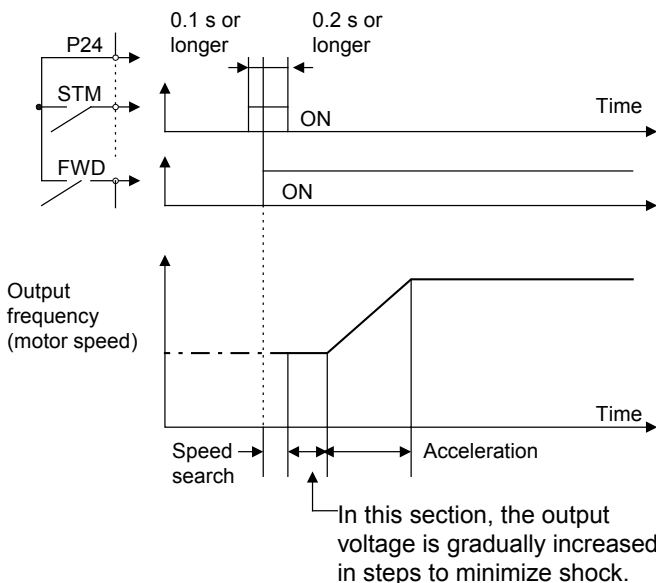

Note: The dotted-dashed line indicates motor speed.

H10 Energy-saving operation

- ◆When the output frequency is fixed (constant-speed operation) at light loads and except for "0.0" is set to F09, "Torque boost 1," this function automatically reduces the output voltage, while minimizing the product (power) of voltage and current.
- ◆Auto tuning(P04/A13: 2) should be done to use this function.
- ◆The energy-saving operation does not be operated when set below.
 - Under Torque control
 - Selected the Automatic torque boost
 - Selected the Torque vector control
 - Under PG vector control

H 1 0 E N E R G Y S A V

Set value 0: Inactive
1: Active

Note:

- Use this function for square law reduction torque loads (e.g., fans, pumps). When used for a constant-torque load or rapidly changing load, this function causes a delay in control response.
- The energy-saving operation automatically stops during acceleration and deceleration and when the torque limiting function is activated.

H11 DEC mode

- ◆This function selects the inverter stopping method when a stop command is entered.

H 1 1 D E C M O D E

Set value 0: Deceleration-to-stop based on data set to "H07 Non-linear acceleration and deceleration"
1: Coasting-to-stop

Note:

This function is effective only when a stop command is entered and, therefore, is ineffective when the motor is stopped by lowering the set frequency.

H12 Instantaneous overcurrent limiting

- ◆An overcurrent trip generally occurs when current flows above the inverter protective level following a rapid change in motor load. The instantaneous overcurrent limiting function controls inverter output and prohibits the flow of a current exceeding the protective level even when the load changes.
- ◆As the operation level of the instantaneous overcurrent limiting function cannot be adjusted, the torque limiting function must be used.

! WARNING

As motor generation torque may be reduced when instantaneous overcurrent limiting is applied, set this function to be inactive for equipment such as elevators, which are adversely affected by reduced motor generation torque, in which case an overcurrent trip occurs when the current flow exceeds the inverter protective level. A mechanical brake should be used to ensure safety.

as accident may result.

H 1 2 I N S T C L

Set value 0: Inactive
1: Active

H13 Auto-restart (Restart time)

◆ Instantaneous switching to another power line (when the power of an operating motor is cut off or power failure occurs) creates a large phase difference between the line voltage and the voltage remaining in the motor, which may cause electrical or mechanical failure. To rapidly switch power lines, write the remaining voltage attenuation time to wait for the voltage remaining in the motor to attenuate. This function operates at restart after a momentary power failure.

H 1 3 R E S T A R T

Setting range: 0.1 to 5.0 seconds

◆ When the momentary power failure time is shorter than the wait time value, a restart occurs following the wait time. When the power failure time is longer than the wait time value, a restart occurs when the inverter is ready to operate (after about 0.2 to 0.5 second).

H14 Auto-restart (Freq. fall rate)

◆ This function determines the reduction rate of the output frequency for synchronizing the inverter output frequency and the motor speed. This function is also used to reduce the frequency and thereby prevent stalling under a heavy load during normal operation.

H 1 4 F A L L R A T E

Setting range: 0.00, 0.01 to 100.00 Hz/s

◆ When 0.00 is set, the frequency is reduced according to the set deceleration time.

Note:

A too large frequency reduction rate is may temporarily increase the regeneration energy from the load and invoke the overvoltage protective function. Conversely, a rate that is too small extends the operation time of the current limiting function and may invoke the inverter overload protective function.

H15 Auto-restart (Holding DC voltage)

◆ This function is for when 2 (deceleration-to-stop at power failure) or 3 (operation continuation) is set to "F14 Restart after momentary power failure (operation selection)." Either function starts a control operation if the main circuit DC voltage drops below the set operation continuation level.

H 1 5 H O L D V

Setting range 230 V series: 200 to 300V
460 V series: 400 to 600V

◆ When power supply voltage to the inverter is high, control can be stabilized even under an excessive load by raising the operation continuation level. However, when the level is too high, this function activates during normal operation and causes unexpected motion. Please contact Fuji electric when changing the initial value.

H16 Auto-restart (OPR command selfhold time)

◆ As the power to an external operation circuit (relay sequence) and the main power to the inverter is generally cut off at a power failure, the operation command issued to the inverter is also cut off. This function sets the time an operation command is to be held in the inverter. If a power failure lasts beyond the self-hold time, power-off is assumed, automatic restart mode is released, and the inverter starts operation at normal mode when power is applied again. (This time can be considered the allowable power failure time.)

H 1 6 S E L F H O L D T

Setting range: 0.0 to 30.0 seconds, 999

When "999" is set, an operation command is held (i.e., considered a momentary power failure) while control power in the inverter is being established or until the main circuit DC voltage is about 100Vdc.

H18 Torque control

◆ This function controls motor torque according to a command value.

Related functions E01toE09 (Set value: 23)

H 1 8 T R Q C T R L

Set value	Operation
0	Inactive (Operation by frequency command)
1	Torque control active 0 to +10V analog voltage input to terminal 12 and the direction of rotation (FWD or REV) is used for the torque command value. 0 is used for 0 to -10V.
2	Torque control active -10 to +10V analog voltage input to terminal 12 and the direction of rotation (FWD or REV) is used for the torque command value.

Torque control block diagram

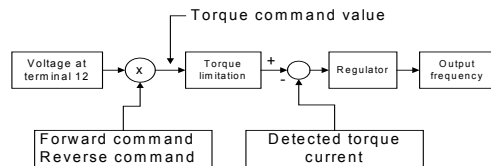

The torque command value is +200% when the voltage at terminal 12 is +10V and is -200% when the voltage is -10V.

◆ Auto tuning(P04/A13: 2) should be done to use this function.

◆ In torque control, the torque command value and motor load determine the speed and direction of rotation.

◆ When the torque is controlled, the upper limit of frequency refers to the minimum value among the maximum frequency, the frequency limiter (upper limiter) value, and 120 Hz. Maintain the frequency at least one-tenth of the base frequency because torque control performance deteriorates at lower frequencies.

◆ If the operation command goes off during a torque control operation, the operation is switched to speed control and the motor decelerates-to-stop. At this time, the torque control function does not operate.

◆ This function cannot be used when the motor 2 is selected.

◆ This function cannot be used for FRN-P11S.

WARNING	The malfunction may be occurred when the set torque is mistaken. (up to upper frequency, maximum frequency or 120Hz) as accident may result.
----------------	--

H19 Active drive

◆ This function automatically extends accelerating time against acceleration operation of 60 seconds or longer to prevent an inverter trip resulting from a temperature rise in inverter due to overcurrent.

H 1 9 A U T R E D

Set value 0: Inactive

1: Active

(When the active drive function is activated, the acceleration time is three times the selected time.)

H20 PID control (Mode select)

H25 PID control(Feedback filter)

◆PID control detects the amount of control (feedback amount) from a sensor of the control target, then compares it with the target value (e.g., reference temperature). If the values differ, this function performs a control to eliminate the deviation. In other words, this control matches the feedback amount with the target value.

This function can be used for flow control, pressure control, temperature control, and other process controls.

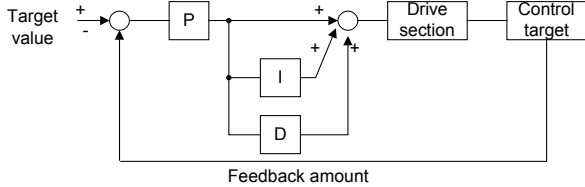

- ◆ Forward or reverse operations can be selected for PID controller output. This enables motor revolutions to be faster or lower according to PID controller output
- ◆ This function cannot be used when the motor 2 is selected.

H 2 0 P I D M O D E

- Set value 0: No operation
 1: Forward operation
 2: Reverse operation

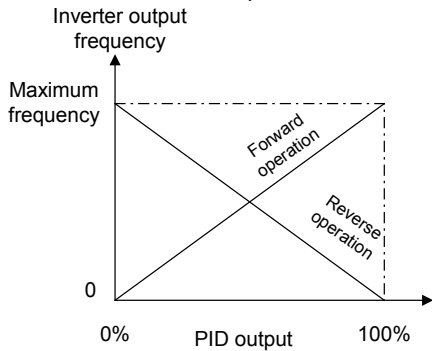

- ◆ The target value can be entered using F01, "Frequency setting 1," or directly from the keypad panel. Select any terminal of Terminals X1 (E01) to X9 (E09) and set value 11 (frequency setting switching).

For entry from F01, "Frequency setting 1," input an OFF signal to the selected terminal. For direct entry from the keypad panel, turn on the selected terminal.

- ◆ For the target value and feedback amount, the process amount can be displayed according to the values set in E40, "Display coefficient A," and E41, "Display coefficient B."

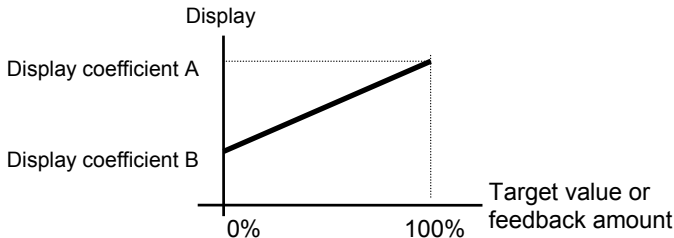

H21 PID control (Feedback signal)

This function selects the feedback amount input terminal and electrical specifications of the terminal. Select a value from the table below according to sensor specifications.

H 2 1 F B S I G N A L

Set value	Descriptions
0	Control terminal 12, forward operation (0 to 10V voltage input)
1	Control terminal C1, forward operation (4 to 20mA current input)
2	Control terminal 12, reverse operation (10 to 0V voltage input)
3	Control terminal C1, reverse operation (20 to 4mA current input)

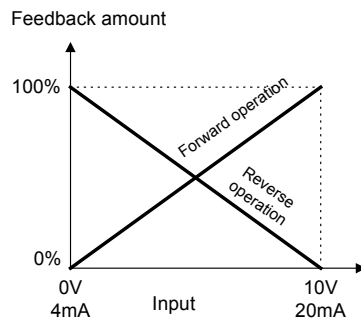

Only positive values can be input for this feedback amount of PID control. Negative values (e.g., 0 to -10V, -10 to 0V) cannot be input, thereby the function cannot be used for a reverse operation by an analog signal.

H22	PID control (P-gain)
H23	PID control (I-gain)
H24	PID control (D-gain)

◆ These functions are not generally used alone but are combined like P control, PI control, PD control, and PID control.

◆ P operation

Operation using an operation amount (output frequency) proportional to deviation is called P operation, which outputs an operation amount proportional to deviation, though it cannot eliminate deviation alone.



H 2 2 P - G A I N

Setting range: 0.01 to 10.0 times

P (gain) is the parameter that determines the response level for the deviation of P operation. Although an increase in gain speeds up response, an excessive gain causes vibration, and a decrease in gain delays response. The value "1" is the P(gain) that is when the maximum frequency 100% at deviation 100%.

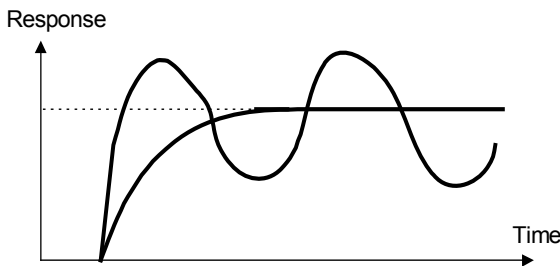

◆ I operation

An operation where the change speed of the operation amount (output frequency) is proportional to the deviation is called an I operation. An I operation outputs an operation amount as the integral of deviation and, therefore, has the effect of matching the control amount (feedback amount) to the target value (e.g., set frequency), though it deteriorates response for significant changes in deviation.

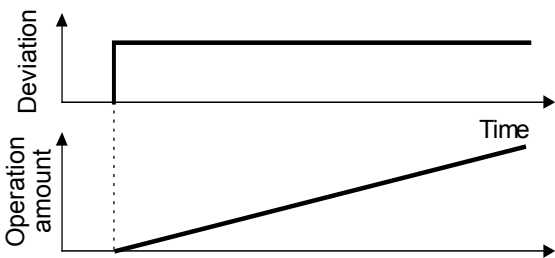

H 2 3 I - G A I N

Setting range: 0.0 (Inactive), 0.1 to 3600 seconds

"H23 I-gain" is used as a parameter to determine the effect of I operation. A longer integration time delays response and weakens resistance to external elements. A shorter integration time speeds up response, but an integration time that is too short causes vibration.

◆ D operation

An operation where the operation amount (output frequency) is proportional to the deviation differential is called a D operation, which outputs an operation amount as the deviation differential and, therefore, is capable of responding to sudden changes.

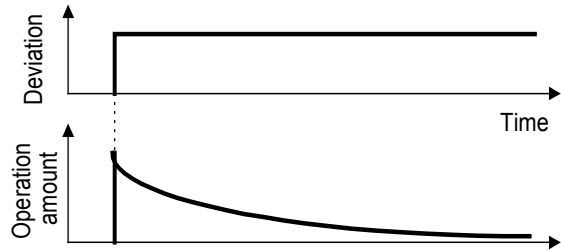

H 2 4 D - G A I N

Setting range: 0.00 (Inactive), 0.01 to 10.0 seconds

"H24 D-gain" is used as a parameter to determine the effect of a D operation. A longer differentiation time causes vibration by P operation quickly attenuating at the occurrence of deviation. Excessive differentiation time could cause vibration. Shortening the differentiation time reduces attenuation at the occurrence of deviation.

◆ PI control

P operation alone does not remove deviation completely. P + I control (where I operation is added to P operation) is normally used to remove the remaining deviation. PI control always operates to eliminate deviation even when the target value is changed or there is a constant disturbance. When I operation is strengthened, however, the response for rapidly changing deviation deteriorates. P operation can also be used individually for loads containing an integral element.

◆ PD control

If deviation occurs under PD control, an operation amount larger than that of D operation alone occurs rapidly and prevents deviation from expanding. For a small deviation, P operation is restricted. When the load contains an integral element, P operation alone may allow responses to vibrate due to the effect of the integral element, in which case PD control is used to attenuate the vibration of P operation and stabilize responses. In other words, this control is applied to loads in processes without a braking function.

◆ PID control

PID control combines the P operation, the I operation which removes deviation, and the D operation which suppresses vibration. This control achieves deviation-free, accurate, and stable responses.

◆ Adjusting PID set value

Adjust the PID value while monitoring the response waveform on an oscilloscope or other instrument if possible. Proceed as follows:

- Increase the value of "H22 P-gain" without generating vibration.
- Decrease the value of "H23 I-gain" without generating vibration.
- Increase the value of "H24 D-gain" without generating vibration.

H30**Serial link (Function select)**

◆The link function (communication function) provides RS-485 (provided as standard) and bus connections (optional).

The serial link function includes:

- 1) Monitoring (data monitoring, function data check)
- 2) Frequency setting
- 3) Operation command
(FWD, REV, and other commands for digital input)
- 4) Write function data

H 3 0 L I N K F U N C

Setting range: 0 to 3

Communication can be enabled and disabled by a digital input. This function sets the serial link function when communication is enabled.

Set value	Frequency command	Operation command
0	Disabled	Disabled
1	Enabled	Disabled
2	Disabled	Enabled
3	Enabled	Enabled

The data monitoring and function data write functions are always enabled. Disabling communication using digital input brings about the same result as when "0" is set to this function. When the bus option is installed, this setting selects the function of the option and the RS-485 interface is restricted to monitoring and writing function data.

H31**RS-485 (Address)**

}

}

H39**RS-485 (Response interval)**

These functions set the conditions of RS-485 Modbus-RTU communication. Set the conditions according to the upstream device. Refer to technical manual for the protocol.

◆This function sets the station address of RTU.

H 3 1 4 8 5 A D R E S S

Setting range: 1 to 247

◆This function sets processing at communication error and sets the error processing timer value.

H 3 2 M O D E O N E R

Setting range: 0 to 3

Set value	Processing at communication error
0	Immediate Er 8 trip (forced stop)
1	Continue operation within timer time, Er8 trip after timer time.
2	Continue operation and effect retry within timer time, then invoke an Er8 trip if a communication error occurs. If an error does not occur, continue operation.
3	Continue operation.

H 3 3 T I M E R

Setting range: 0.0 to 60.0 seconds

◆This function sets the baud rate.

H 3 4 B A U D R A T E

Setting range: 0 to 3

Set value	Baud rate
0	19200 bit/s
1	9600 bit/s
2	4800 bit/s
3	2400 bit/s

◆This function sets data length.

H 3 5 L E N G T H

Setting range: 0

Set value	Data length
0	8 bit

◆This function sets the parity bit.

H 3 6 P A R I T Y

Setting range: 0 to 2

Set value	Parity bit
0	None
1	Even
2	Odd

◆This function sets the stop bit.

H 3 7 S T O P B I T S

Setting range: 0, 1

Set value	Stop bit
0	2 bit
1	1 bit

The stop bit is automatically configured by the value of the parity bit. For parity "NONE" the stop bit is 2bits. For parity "EVEN" or "ODD" the stop bit is 1 bit.

◆In a system where the local station is always accessed within a specific time, this function detects that access was stopped due to an open-circuit or other fault and invokes an Er 8 trip.

H 3 8 N O R E S t

Setting range: 0 (No detection)
1 to 60 seconds

◆This function sets the time from when a request is issued from the upstream device to when a response is returned.

H 3 9 I N T E R V A L

Setting range: 0.00 to 1.00 second

Motor 2 (A:Alternative Motor Parameters)

A01 Maximum frequency2

◆ This function sets the maximum frequency for motor 2 output by the inverter. This function operates the same as "F03 Maximum frequency 1." For details, see the explanation for F03.

A 0 1 M A X H z - 2

A02 Base frequency 2

◆ This function sets the maximum output frequency in the constant-torque area of motor 2 (i.e., output frequency at rated output voltage). This function operates the same as "F04 Base frequency 1." For details, see the explanation for F04.

A 0 2 B A S E H z - 2

A03 Rated voltage 2

◆ This function sets the rated value of voltage output to motor 2. This function operates the same as "F05 Rated voltage 1." For details, see the explanation for F05.

A 0 3 R A T E D V 2

A04 Maximum voltage 2

◆ This function sets the maximum value of the inverter output voltage of motor 2. This function operates the same as "F06 Maximum voltage 1." For details, see the explanation for F06.

A 0 4 M A X V - 2

A05 Torque boost 2

◆ This function sets the torque boost function of motor 2. This function operates the same as "F09 Torque boost 1." For details, see the explanation for F09.

A 0 5 T R Q B O O S T 2

A06 Electronic thermal overload relay 2 (Select)

A07 Electronic thermal overload relay 2 (Level)

A08 Electronic thermal overload relay 2 (Thermal time constant)

◆ This function sets the function of the electronic thermal overload relay for motor 2. This function operates the same as F10 to F12, "Electronic thermal overload relay 1." For details, see the explanations for F10 to F12.

A 0 6 E L C T R N O L 2

A 0 7 O L L E V E L 2

A 0 8 T I M E C N S T 2

A09 Torque vector control 2

◆ This function sets the torque vector function of motor 2. This function operates the same as "F42 Torque vector control 1." For details, see the explanation for F42.

A 0 9 T R Q V E C T O R 2

A10 Number of motor-2 poles

◆ This function sets the number of poles of motor 2 to be driven. This function operates the same as "P01 Number of motor-1 poles." For details, see the explanation for P01.

A 1 0 M 2 P O L E S

A11 Motor 2 (Capacity)

◆ This function sets the capacity of motor 2. This function operates the same as "P02 Motor 1 (Capacity)." For details, see the explanation for P02. However, the related motor data functions change to "A12 Motor 2 (Rated current)," "A15 Motor 2 (No-load current)," "A16 Motor 2 (%R1 setting)," and "A17 Motor 2 (%X setting)."

A 1 1 M 2 - C A P

A12 Motor 2 (Rated current)

◆ This function sets the rated current of motor 2. This function operates the same as "P03 Motor 1 (Rated current)." For details, see the explanation for P03.

A 1 2 M 2 - I r

A13 Motor 2 (Tuning)

◆ This function sets the auto tuning of motor 2. This function operates the same as "P04 Motor 1 (Tuning)." For details, see the explanation for P04.

A 1 3 M 2 T U N 1

A14 Motor 2 (On-line tuning)

◆ This function sets the online tuning of motor 2. This function operates the same as "P05 Motor 1 (On-line tuning)." For details, see the explanation for P05.

A 1 4 M 2 T U N 2

A15 Motor 2 (No-load current)

◆ This function sets the no-load current of motor 2. This function operates the same as "P06 Motor 1 (No-load current)." For details, see the explanation for P06.

A 1 5 M 2 - I o

A16 Motor 2 (%R1 setting)

A17 Motor 2 (%X setting)

◆ This function sets %R1 and %X of motor 2. This function operates the same as "P07 Motor 1 (%R1 setting)," and "P08 Motor 1 (%X setting)." For details, see the explanations for P07 and P08.

A 1 6 M 2 - % R 1

A 1 7 M 2 - % X

A18 Slip compensation control 2

◆ This function sets the amount of slip compensation for motor 2. This function operates the same as "P09 Slip compensation control." For details, see the explanation for P09.

A 1 8 S L I P C O M P 2

Set value : 0.00Hz to 15.00Hz

◆ Calculate the amount of slip compensation using the following formula:

$$\text{Slip compensation amount} = \text{Base frequency} \times \frac{\text{Slippage [r/min]}}{\text{Synchronous speed [r/min]}} [\text{Hz}]$$

Slippage = Synchronous speed - Rated speed

U : User function

U01 Maximum compensation frequency during braking torque limit

◆ This function becomes effective, when the torque limit (brake) is used. The inverter controls to increase the output frequency so that torque calculations do not exceed the torque limit (brake) setting (F41 or E17). (When F41 or E17 is set to 999, it becomes invalid.) This function sets the increment of upper limit for output frequency.
When the regeneration avoidance is selected, the resurrection ability can be improved by raising the increment of upper limit. However, the output frequency of the inverter is limited at the frequency limit(high): F15.

U 0 1 U S E R 0 1

Setting range : 0 to 65535

The set value "15" becomes 1Hz.
(The set value "1" becomes 1/15Hz)

U02 1st S-shape level at acceleration (start)

U03 2nd S-shape level at acceleration (stop)

U04 1st S-shape level at deceleration (start)

U05 2nd S-shape level at deceleration (stop)

◆ When "2" is set in the function code: H07, both curvilinear acceleration and deceleration ranges of S-shape can be set up arbitrarily.
The range is the ratio for maximum output frequency 1 (F03) or 2 (A01) .

U 0 2 U S E R 0 2
U 0 3 U S E R 0 3
U 0 4 U S E R 0 4
U 0 5 U S E R 0 5

Setting range : 1 to 50%

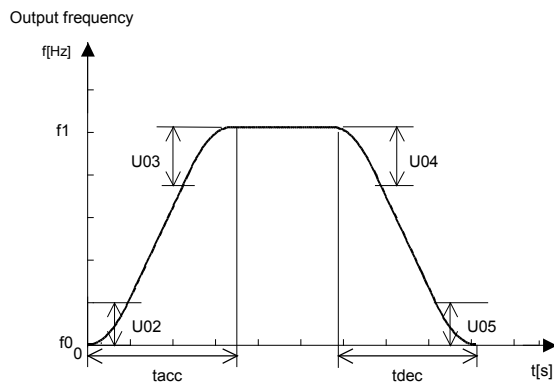

◆ 100% value of this function means maximum frequency (f_{max}) .
Acceleration time " t_{acc} " and deceleration time " t_{dec} " of upper figure become longer than the linear acceleration time and deceleration time. When the set acceleration time(F07, E10, E12, E14) is assumed to be " T_a " and deceleration time(F08, E11, E13, E15) is assumed to be " T_d ", " t_{acc} " and " t_{dec} " can be calculated by the following expressions.

- At acceleration,

$$|f_1 - f_0| \geq f_{max} \times \frac{U_{02} + U_{03}}{100} \quad \text{or,}$$

- At deceleration,

$$|f_1 - f_0| \geq f_{max} \times \frac{U_{04} + U_{05}}{100}$$

$$t_{acc} = \left(\frac{f_1 - f_0}{f_{max}} + \frac{U_{02} + U_{03}}{100} \right) \times T_a$$

$$t_{dec} = \left(\frac{f_1 - f_0}{f_{max}} + \frac{U_{04} + U_{05}}{100} \right) \times T_d$$

↑ linear Acceleration and deceleration clause ↑ S-shape clause

- At acceleration,

$$|f_1 - f_0| < f_{max} \times \frac{U_{02} + U_{03}}{100} \quad \text{or,}$$

- At deceleration,

$$|f_1 - f_0| < f_{max} \times \frac{U_{04} + U_{05}}{100}$$

$$t_{acc} = 2 \times \left\{ \sqrt{\frac{f_1 - f_0}{f_{max}} \times \frac{100}{U_{02} + U_{03}}} \right\} \times \left(\frac{U_{02} + U_{03}}{100} \right) \times T_a$$

$$t_{dec} = 2 \times \left\{ \sqrt{\frac{f_1 - f_0}{f_{max}} \times \frac{100}{U_{04} + U_{05}}} \right\} \times \left(\frac{U_{04} + U_{05}}{100} \right) \times T_d$$

U08 Initial value of main DC link capacitor

U09 Measured value of main DC link capacitor

◆ Data for the life expectancy judgment of the capacitor in main circuit is stored in this function. The electrical discharge time of the capacitor can be measured automatically, and the time of part replacement can be confirmed according to the decrement rate from the factory shipment.

U 0 8 U S E R 0 8
U 0 9 U S E R 0 9

Setting range : 0 to 65535

◆ The electrical discharge time which is measured in the factory shipment is set to function code U08 as a initial value. This value is different in each inverter.
◆ The electrical discharge time of the capacitor is measured automatically, when the power supply is turned off. And, the result is stored in function code U09.

When the power supply is turned off under the conditions as follows, decrement rate (%) to the factory shipment can be measured.

Conditions: which has been described to "Estimation of life expectancy based on maintenance information" of the instruction manual "8-2 periodical inspection".

The result of $\frac{U_{09}}{U_{08}} \times 100$ is displayed in CAP=xxx.x%

of maintenance information. 85% becomes a standard at the part replacement time.

◆ When you make measurement of capacity and life expectancy judgment of capacitor with an actual operating condition, set the value "30" to the function code "E20 to E24". And write the measurement result U09 with an actual operating condition to the function code U08 as an initial value as early as possible since inverter operation starts.

However, life judgment by the measurement result cannot be performed in case of 1 and 2 as below.

1. During inverter operation, a power supply is turned off and it stops.
2. Cooling fan ON/OFF control is used.
(function code : H 06= 1)

Turn off the power supply of inverter, on the conditions at which the inverter has stopped, and a cooling fan is operated. It is not necessary to remove an option card and the connection with a control terminal.

As for this "measurement with an actual operating condition", carry out this measurement about 10 times to minimize the error of a measurement result, and make the average value into an initial value.

Moreover, when there is 10% or more of change from the last measured value, measurement is disregarded in order to prevent incorrect measurement. Renewal of a display is not carried out.

◆ Set measured value U09 to the initial value U08 after exchanging capacitors.

Related Functions
E20 to E24
(Set value: 30)

U10 PC board capacitor powered on time

◆ The accumulation time of the capacitor on PC board are displayed. The accumulation time of the control power supply multiplied by the life expectancy coefficient defined by the temperature inside the inverter are displayed. Hence, the hours displayed may not agree with the actual operating hours. Since the accumulation time are counted by unit hours, power input for less than one hour will be disregarded.

The accumulation time are displayed in TCAP=xxxxxh of maintenance information. The standard at the replacement time is 61,000h. Refer to the manual "8-2 regular check" for the maintenance.

U 1 0 U S E R 1 0

Setting range : 0 to 65535 hours

◆ Clear the accumulation time to 0 hour, after replacing the PC board on which capacitors are equipped with. There is also PC Board without the capacitor (ex :Control circuit board) not to be cleared the accumulation time. For details, contact Fuji Electric.

Related Functions
E20 to E24
(Set value: 30)

U11 Cooling fan operating time

◆ The integrated operating hours of the cooling fan are displayed. Since the integrated hours are counted by unit hours, power input for less than one hour will be disregarded. The integrated hours are displayed in TFAN=xxxxxh of maintenance information.

The standard at the replacement time is 40,000h in the inverter of 5HP or less. The standard at the replacement time is 25,000h in the inverter of 7.5HP or more. (Estimated life expectancy of a cooling-fan at inverter ambient temperature of 40 degree.)

The displayed value should be considered as a rough estimate because the actual life of a cooling fan is

influenced significantly by the temperature. Refer to the manual "8-2 regular check" for the maintenance.

U 1 1 U S E R 1 1

Setting range : 0 to 65535 hours

◆ Clear integrated operating time to 0 hour after replacing the cooling fan.

Related Functions
E20 to E24
(Set value: 30)

U13 Magnetize current vibration damping gain

◆ Adjust if Magnetize current vibration was occurred in the inverter output current .

U 1 3 U S E R 1 3

Setting range: 0 to 32767

◆ Adjust the value from 0 to 2048 as a standard value. Vibration damping gain becomes 100% in set value 4096.

U15 Slip compensation filter time constant

◆ The filter time constant of Slip compensation is set.

U 1 5 U S E R 1 5

Setting range : 0 to 32767

◆ Calculate the filter time constant using the following formula.

$$Filter\ time\ constant = \frac{2^{16}}{"U15" set\ value} [ms]$$

◆ The response time of the control slows because the filter time constant is enlarged when a value is set to smaller. However, system becomes steady.

◆ The response time of the control quickens because the filter time constant becomes smaller, when a set value is enlarged.

Note : Response time quickens when a set value is enlarged. Therefore, there is a possibility that the output frequency becomes unstable. Please adjust a set value to smaller than factory setting value.

U23 Integral gain of continuous operation at power failure

U24 Proportional gain of continuous operation at power failure

◆ This function becomes effective, when function code F14 (Restart mode after momentary power failure) set value is 2 or 3.

U 2 3 U S E R 2 3

U 2 4 U S E R 2 4

Setting range : 0~65535

◆ In case of F14 set value : 2.

When the operation continuation level (H15) is reached, deceleration to a stop occurs. The DC voltage of the main circuit sharpens the deceleration slope, and the inverter collects the inertia energy of the load to maintain the DC bus voltage and controls the motor until it stops, so that the undervoltage protective function is not activated.

The deceleration slope is adjusted with U23 and U24. However, the deceleration operation time never becomes longer than the set deceleration time.

◆ In case of F14 set value : 3.

The output frequency is lowered by the control by which the DC voltage of the main circuit is kept constant from the regeneration energy, so that the inverter may continue operation when momentary power failure occurs.

The response is adjusted with U23 and U24 at this time.

◆ Calculate the integral gain using the following formula.

$$\text{Integral gain} = \frac{2^{16}}{\text{"U23" set value}} \quad [\text{ms}]$$

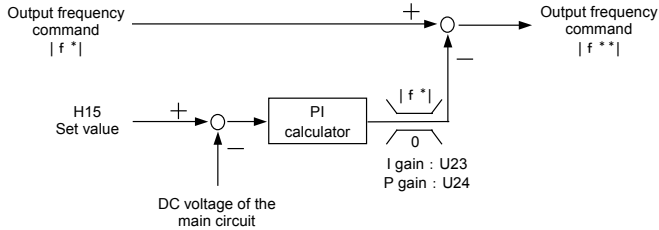

U48 Input phase loss protection

◆ This function selects operation of input phase loss or power supply unbalance protection.

U 4 8 U S E R 4 8

Setting range : 0 to 2

Set value	Operation
0	Active (without reactor (ACR/DCR))
1	Active (with reactor (ACR/DCR))
2	Inactive

CAUTION

When "2" is set to U48, protection operation of the inverter to input phase loss or power supply voltage unbalance does not work. If you use it as it is, there is a possibility of damaging an inverter.
Failure may result.

U49 RS-485 protocol selection

◆ The protocol of RS-485 communication is changed.

U 4 9 U S E R 4 9

Set value : 0, 1

Set value	Operation
0	FGI-bus
1	Modbus-RTU

Instruction manual and specifications are prepared about communicative details. Contact Fuji Electric.

U56 Speed agreement /PG error(Detection width)

U57 Speed agreement /PG error (Detection timer)

U58 PG error selection

◆ These functions are effective for the option card (OPC-G11S-PG, -PG2, -PGA).

Refer to each manual.

U 5 6 U S E R 5 6

U 5 7 U S E R 5 7

U 5 8 U S E R 5 8

U59

Braking - resistor function select [30HP or less is corresponded]

◆ When function code F13 (electronic thermal) is set to 2, both the type of the braking resistor and connection circuit are set. Factory setting is set to nominal applied resistor and the number of resistor is one. When the power load capacities of resistor are increased, set the factory setting properly

U 5 9 U S E R 5 9

Setting range : 0 to A8 (HEX)

Setting of ten's digit (type selection)

Set value	Type braking resistor	Resistance [Ω]	Capacity [W]	Duty cycle [%ED]
0	Standard applied resistor	-	-	10%
1	DB0.75-2C	100	200	10%
2	DB2.2-2C	40	400	
3	DB3.7-2C	33	400	
4	DB5.5-2C	20	800	
5	DB7.5-2C	15	900	
6	DB0.75-4C	200	200	
7	DB2.2-4C	160	400	
8	DB3.7-4C	130	400	
9	DB5.5-4C	80	800	
A	DB7.5-4C	60	900	

Setting of unit's digit (connection circuit selection)

Set value	Braking-resistor		*1) Duty cycle [%ED]	Synthetic resistance [Ω]	Power consumption per resistance [comparatively]
	Use number	Connection circuit			
0	1		10%	R	100%
1	2		20%	2R	50%
2	2		20%	(1/2)R	50%
3	4		40%	R	25%
4	3		30%	3R	33%
5	6		50%	(3/2)R	17%
6	9		50%	R	11%
7	4		40%	4R	25%
8	8		50%	2R	12.5%

1) It is limited by the %ED value of the braking transistor inside the inverter.

⚠ CAUTION

- ◆ Set the function code both "F13" and "U59" before operating the inverter, and don't change the functions during operation. The integrated thermal data are cleared immediately, when function code "F13" or "U59" are changed. The overheat protection of resistor becomes invalid. When the function code "F13" or "U59" are changed in the state where temperature rose, the overheat protection of resistor becomes invalid, too.
- ◆ As there is a possibility of damaging the inverter, the resistor value less than standard applied value should not be available.
- ◆ Make into one kind the resistor used as combination conditions for a braking resistor, and connect it so that the electric power is consumed equally in each resistor.
- ◆ When the resistor which is instead of DB***-2C/4C are used as External braking resistor, function code F13 should be set to "0".
- ◆ When resistor values less than Standard applied resistor value is set to the function code, regeneration operation is invalid. OU alarm will be occurred.
- ◆ If connection of resistor and setting value of resistor is not corresponded, there is a possibility of damaging the resistor and the inverter.

Failure may result.

U59

Function for manufacturer
[40HP or more is corresponded]

This function is available to release the overheating alarm (OH1) at the DC fan broken.

U 5 9 U S E R 5 9

Set value : 00, 01

Set value	Operation
00	OH1 alarm at DC fan broken
01	No alarm at DC fan broken

⚠ CAUTION

- ◆ It causes overheating trip (OH1,OH3) in the inverter, and the life time decrease such as electrolytic capacitors on the PCB in the unit by a partial rise temperature, and there is a possibility to the worst unit damage when left with the DC fan for an internal stir stops.
Be sure that set it to the fan exchange and the factory setting value again promptly after the DC fan for an internal stir stops. (Contact the fan exchange procedure Fuji Electric.)

Failure may result.

U60

Regeneration avoidance at deceleration

- ◆ This function is available, when torque limit (brake) of F41(or E17) is set to "0%".

U 6 0 U S E R 6 0

Set value : 0, 1

Set value	Operation
0	Torque limit operation (for high response use)
1	OU alarm avoidance operation (for only deceleration or Large inertia use)

- ◆ If function code U60 is set to "0", braking torque is kept to about "0%" under acceleration, deceleration, constant speed state. Output frequency is controlled in correspond to the rapid change in motor load to prevent OU alarm. Deceleration time becomes longer than the set deceleration time (F08).
- ◆ In case of setting value U60:1, Compared with setting value "0", it controls not to perform torque limit operation only at the deceleration time, but to prevent the rise of the DC voltage of the main circuit, and avoid OU alarm.
At this time, although deceleration time becomes longer than a setting value of F08, it becomes shorter than setting value "0" of U60. It may occur OU alarm, if load changes rapidly during deceleration.

U61

Voltage detect offset and gain adjustment

- ◆ 40HP or more :

It adjusts, only when a print board is replaced by maintenance, etc. If not necessary, do not use this function.

U 6 1 U S E R 6 1

Set value : 0, 1, 2

Inverter capacity	Operation
30HP or less	0 : Inactive(fixed)
40HP or more	0 : Inactive 1 : Voltage detect offset adjustment 2 : Voltage detect gain adjustment

- ◆ Set the function code in the following procedure.

If the inverter are operated without this adjustment after replacing the PC board, normal operation may not be able to be performed.

(Offset adjustment)

- 1) Confirm that the main power supply is turned ON, the motor wiring are connected and the motor has stopped (inverter operation command is OFF).
- 2) When the data of U61 is changed to "1", and the FUNC/DATA key is ON, the offset self adjustment is started. The display of "storing" of the keypad panel disappears several seconds later. When the set value returns to "0", adjustment is completed.
If the main power supply is turned OFF, while outputting alarm, motor is driving, coast-to-stop command(BX) is ON and this adjustment is started, the inverter becomes "Er7:TUNING ERROR".
In this case, start the adjustment after removing the above-mentioned factor.

(Gain adjustment)

- 1) Drive the motor in an arbitrary frequency of about 10 to 60Hz(However, constant speed) after executing the above-mentioned offset adjustment.(U61:1)
At this time, gain adjustment is available unrelated to the load state.
- 2) When the data of U61 is changed to "2", and the FUNC/DATA key is ON, the gain self adjustment is started. The display of "storing" of the keypad panel disappears several seconds to 30 seconds later. When the set value returns to "0", adjustment is completed.
If inverter is not operated, this adjustment is not available.

U89**Motor overload memory retention**

◆ This is Motor overload memory (Electrical thermal O/L relay) retention selection at power up.

U 8 9 U S E R 8 9

Setting range : 0, 1

Set value	Operation
0	Inactive When power up the drive, Motor overload data is reset.
1	Active. When power is down, the drive stores Motor overload data and use this data at next power up.

6. Protective Operation

6-1 List of Protective Operations

In the event of an abnormality in the inverter, the protective function will activate immediately to trip the inverter, display the alarm name on the LED monitor, and the motor coasts-to-a stop. For alarm contents, see Section 6.1.1.

Table 6.6.1 List of alarm displays and protective functions

Alarm Name	Keypad panel display		Contents of operation	
	LED	LCD		
Over current	OC1	OC DURING ACC	During acceleration	If the inverter output current momentarily exceeds the overcurrent detection level due to an overcurrent in the motor, or a short-circuit or a ground fault in the output circuit, the protective function is activated.
	OC2	OC DURING DEC	During deceleration	
	OC3	OC AT SET SPD	Running at constant speed	
Ground fault	EF	GROUND FAULT	If a ground fault in the inverter output circuit is detected, the protective function is activated (for 40HP or more only). If a ground fault occurs in an inverter rated at 30HP or less, the inverter is protected by the overcurrent protection. If protection against personal injury or property damage is required, install a ground-fault protective relay or earth-leakage circuit breaker separately.	
Overvoltage	OU1	OV DURING ACC	During acceleration	If the DC link circuit voltage of the main circuit exceeds the overvoltage detection level (230V series: 400V DC, 460V series: 800V DC) due to an increase in the regenerating current from the motor, the output is shut down. However, protection against inadvertent overvoltage apply (e.g., high-voltage line) may not be provided.
	OU2	OV DURING DEC	During deceleration	
	OU3	OV AT SET SPD	Running at constant speed	
Undervoltage	LU	UNDERVOLTAGE	If the DC link circuit voltage of the main circuit falls below the undervoltage detection level (230V series: 200V DC, 460V series: 400V DC) due to a lowered power supply, the output is shut down. If function code F14 (Restart after momentary power failure) is selected, an alarm is not displayed. In addition, if the supply voltage falls to a level unable to maintain control power, an alarm may not be displayed.	
Input open-phase	Lin	PHASE LOSS	If the inverter is driven with any one of the three phases connected to L1/R, L2/S and L3/T of the main circuit power supply "open", the rectifying diodes or smoothing capacitors may be damaged, at such time an alarm is issued and the inverter is tripped.	
Overheating of heat sink	OH1	FIN OVERHEAT	If the temperature of the heat sink rises due to a cooling fan failure, etc., the protective function is activated.	
External alarm	OH2	EXT ALARM	If the external alarm contacts of the braking unit, braking resistor or external thermal O/L relay are connected to the control circuit terminals (THR), this alarm will be actuated according to contact off signal. When the PCT thermal protection is activated(H26:1), it operates when the detected temperature is increased.	
Inverter internal overheating	OH3	HIGH AMB TEMP	If the temperature inside the inverter rises due to poor ventilation, etc., the protective function is activated. Overcurrent of the terminal 13(20mA or more) due to the short circuit between the terminal 13 and 11, etc., the protective function is activated.	
Overheating of braking resistor	dbH	DBR OVERHEAT	If electronic thermal O/L relay (for braking resistor) function code F13 is selected, the protective function is activated to prevent the resistor from burning due to overheating following frequent use of the braking resistor.	
Motor 1 overload	OL1	MOTOR1 OL	The protective function is activated if the motor current exceeds the preset level, provided that electronic thermal O/L relay 1 function code F10 has been selected.	
Motor 2 overload	OL2	MOTOR2 OL	If the second motor current exceeds the preset level when the operation is switched to drive the second motor, the protective function is activated, provided that electronic thermal O/L relay 2 of function code A04 is selected.	
Inverter overload	OLU	INVERTER OL	If the output current exceeds the rated overload current, the protective function is activated to provide thermal protection against semiconductor element overheating in the inverter main circuit.	
Blown fuse	FUS	DC FUSE OPEN	If the fuse in the inverter is blown out following a short-circuit or damage to the internal circuit, the protective function is activated (for 40HP or more only).	
Memory error	Er1	MEMORY ERROR	If a memory error occurs, such as missing or invalid data, the protective function is activated.	
Keypad panel communication error	Er2	KEYPD COM ERR	If a communication error or interrupt between the keypad panel and control circuit is detected, the protective function is activated.	
CPU error	Er3	CPU ERROR	If an CPU error occurs due to noise, etc., the protective function is activated.	
Option error	Er4	OPTN COM ERR	Error when using an optional unit	
	Er5	OPTION ERROR		
Forced stop	Er6	OPR PROCD ERR	Error when using the forced stop command	
Output wiring error	Er7	TUNING ERROR	If there is an open circuit or a connection error in the inverter output wiring during performing auto-tuning, the protective function is activated.	
RS-485 communication error	Er8	RS-485 COM ERR	If an error occurs when using RS-485, the protective function is activated.	

6-2 Alarm Reset

To release the trip status, enter the reset command by pressing the **RESET** key on the keypad panel or inputting signal from the terminal (RST) of the control terminals after removing the cause of the trip. Since the reset command is an edge operation, input a command such as !!OFF-ON-OFF!! as shown in Fig.6-2-1.

When releasing the trip status, set the operation command to OFF. If the operation command is set to ON, inverter will start operation after resetting.

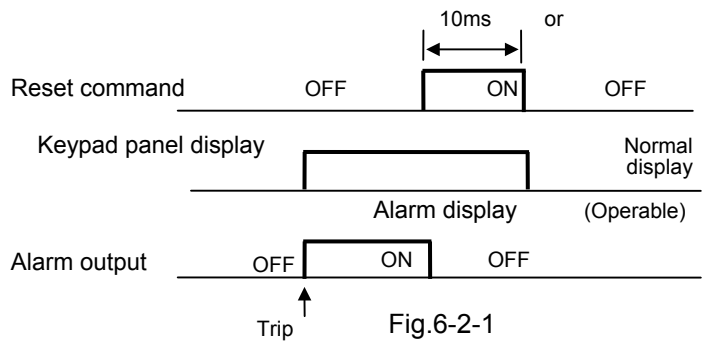

WARNING

If the alarm reset is activated with the operation signal ON, the inverter will restart suddenly, which may be dangerous. To ensure safety, disable the operating signal when releasing the trip status. **as accident may result.**

7. Trouble shooting

7.1 Protective function activation

(1) Overcurrent

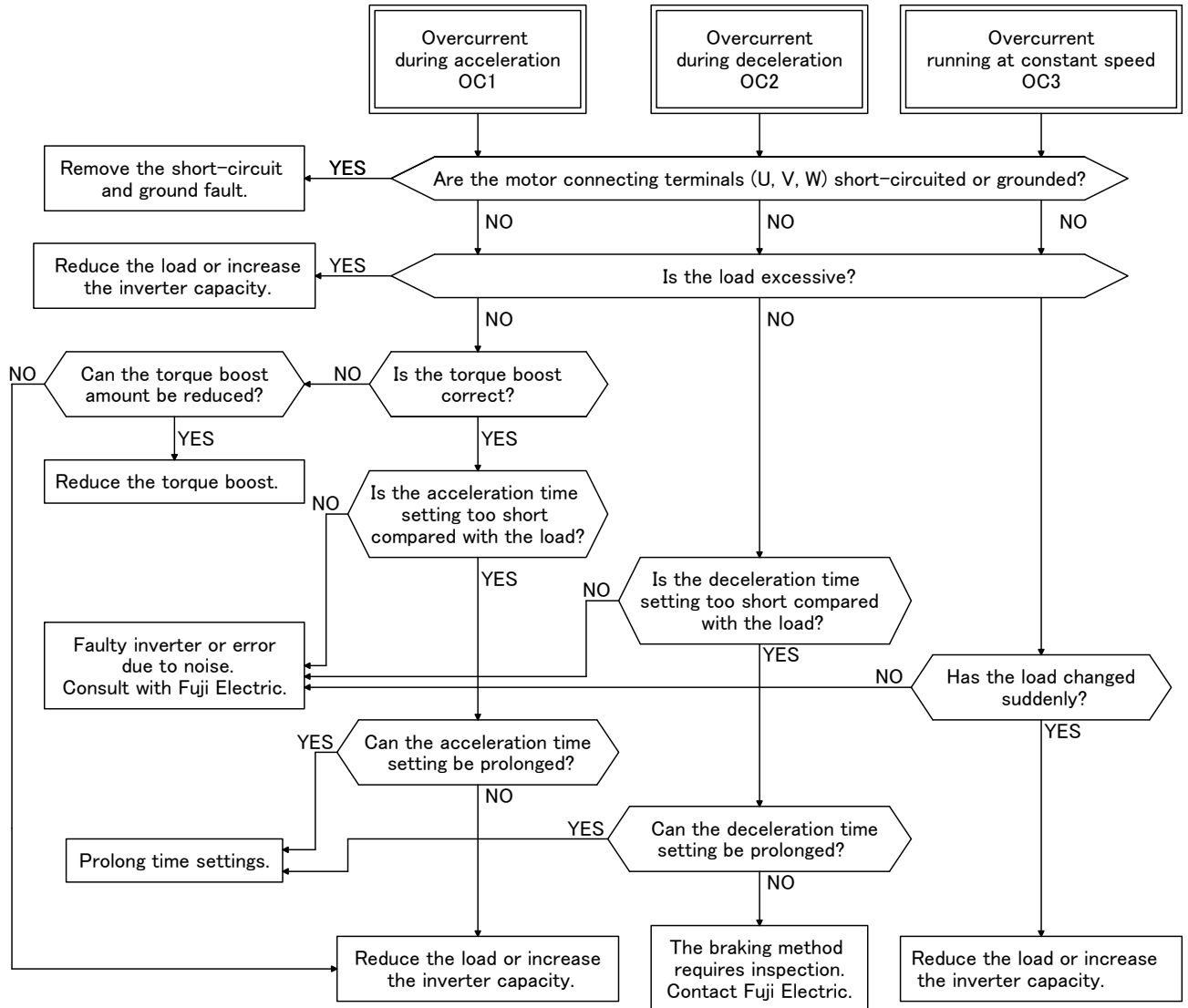

(2) Ground fault

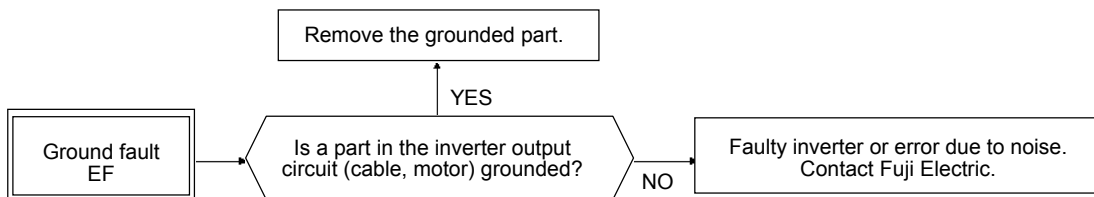

Note: The ground fault protective function is provided only for inverter for nominal applied motors rated at 40HP or more.

(3) Fuse brown

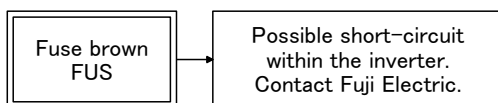

(4) Overvoltage

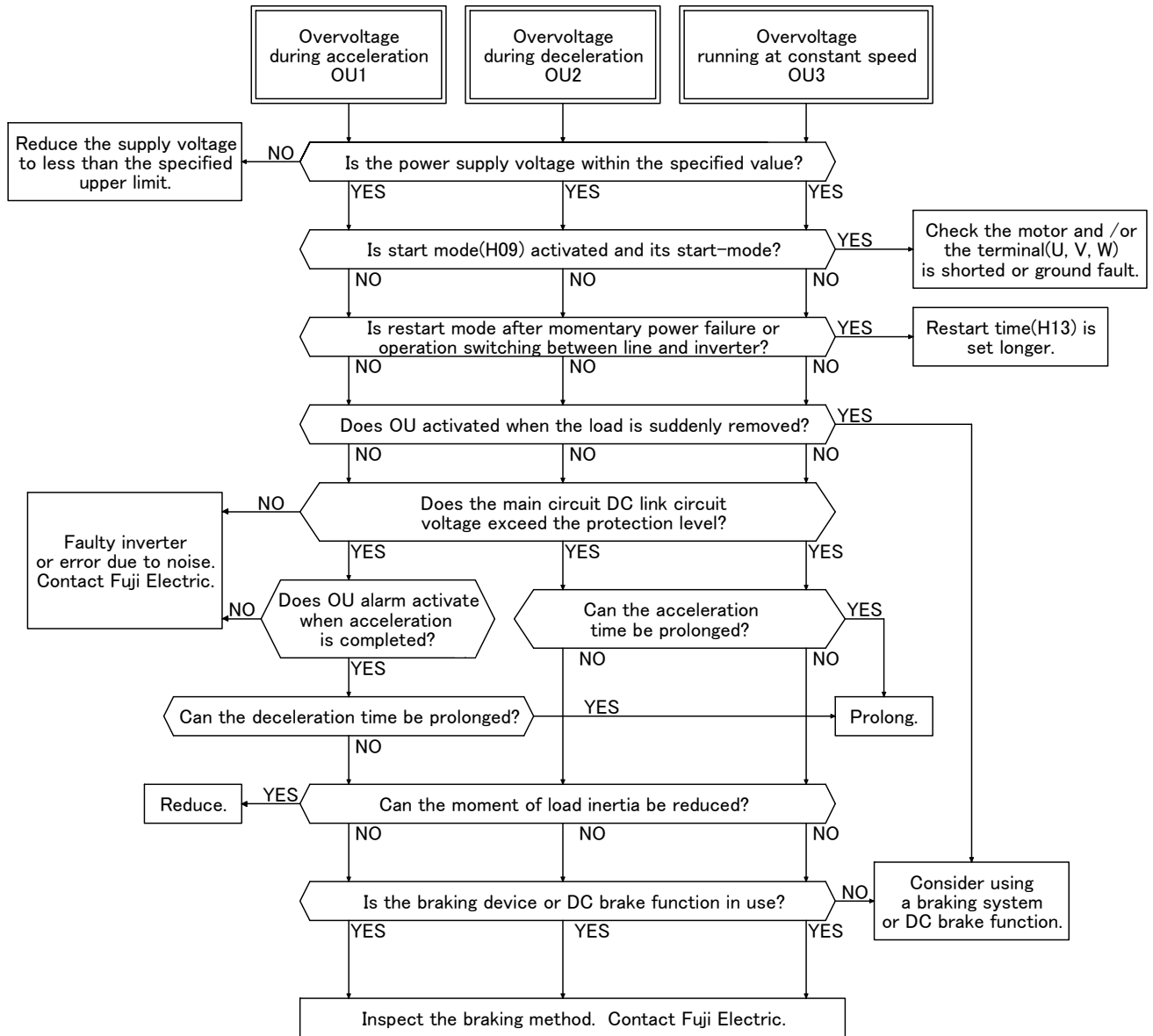

(5) Low voltage

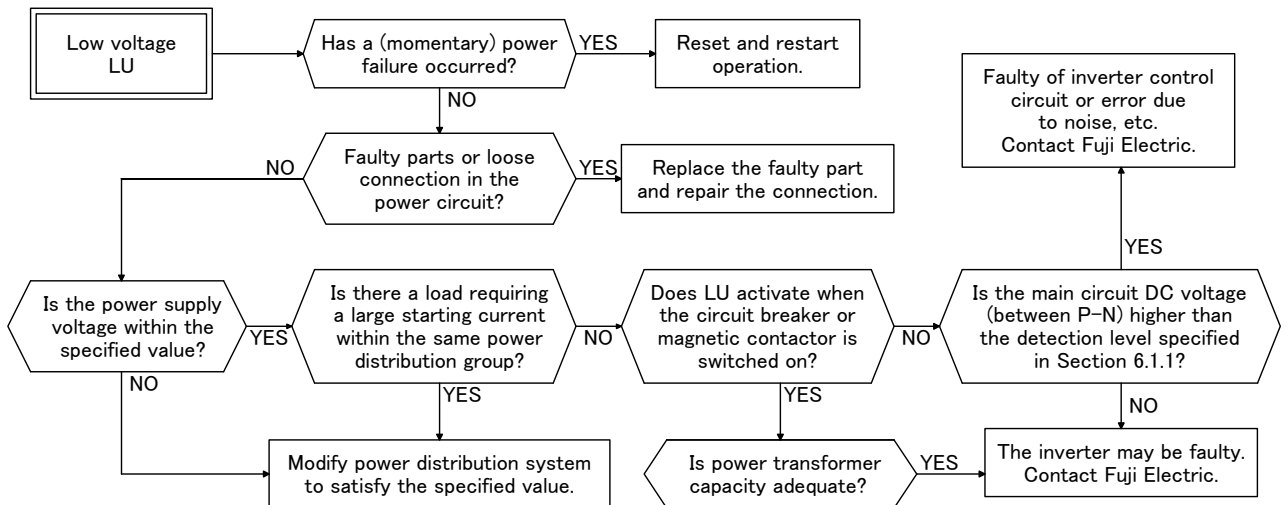

(6) Overtemperature at inside air and overheating at heatsink.

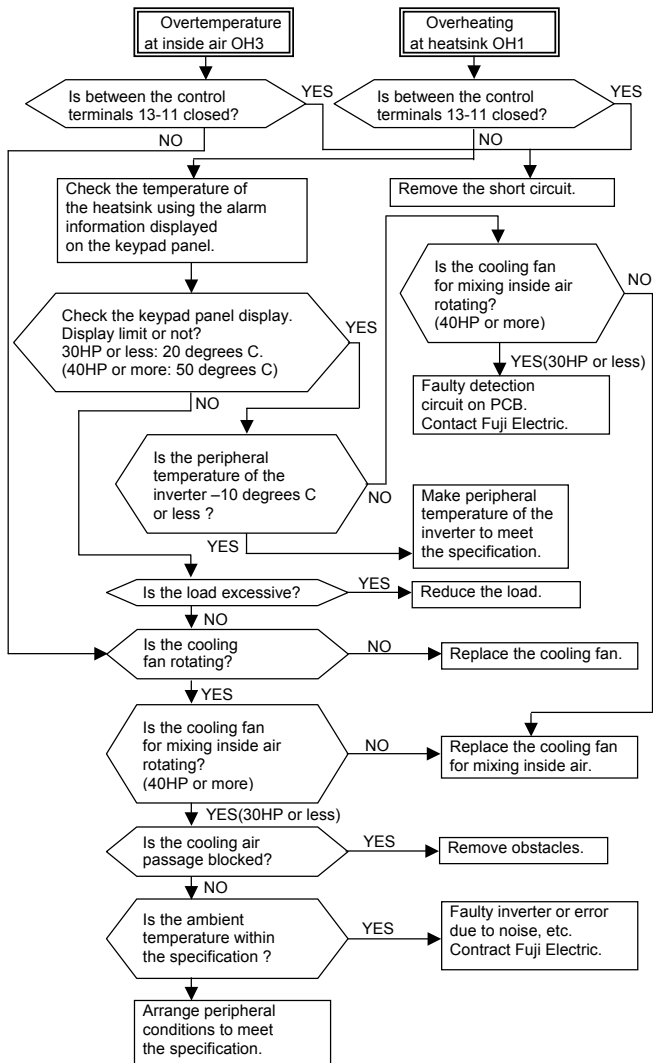

(7) External thermal relay tripped

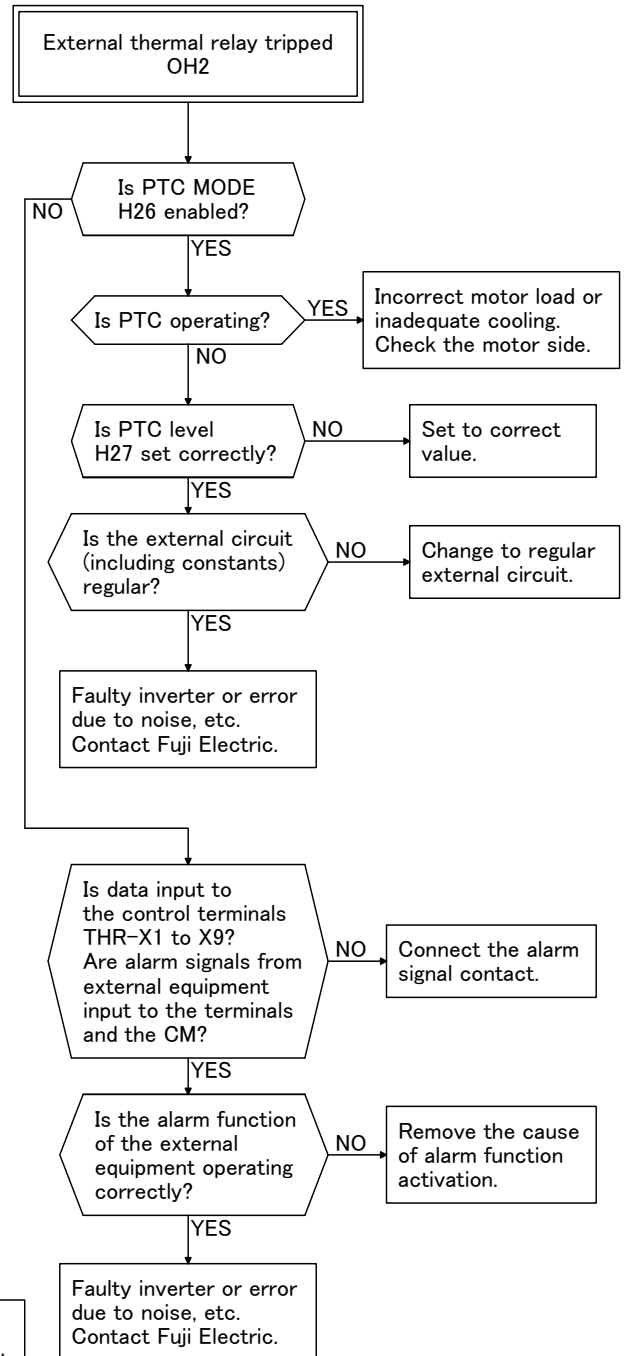

(8) Inverter unit overload and motor overload

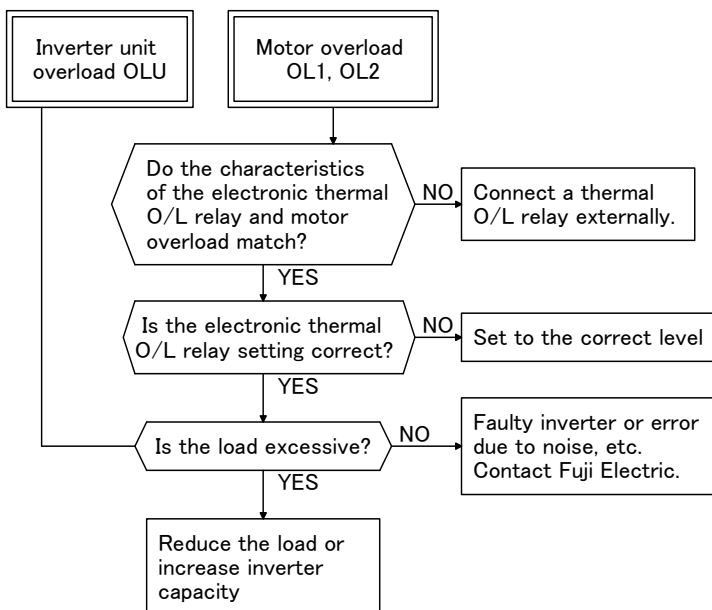

(9) Memory error Er1,
Keypad panel communication error Er2,
CPU error Er3

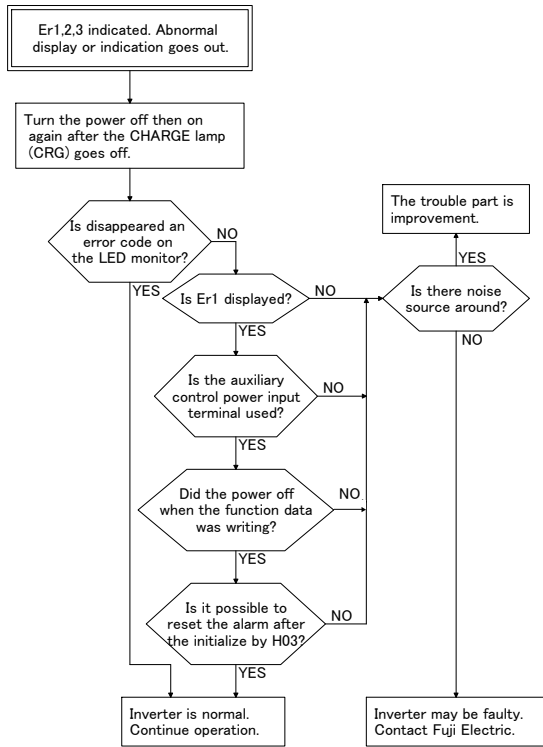

(10) Output wiring error

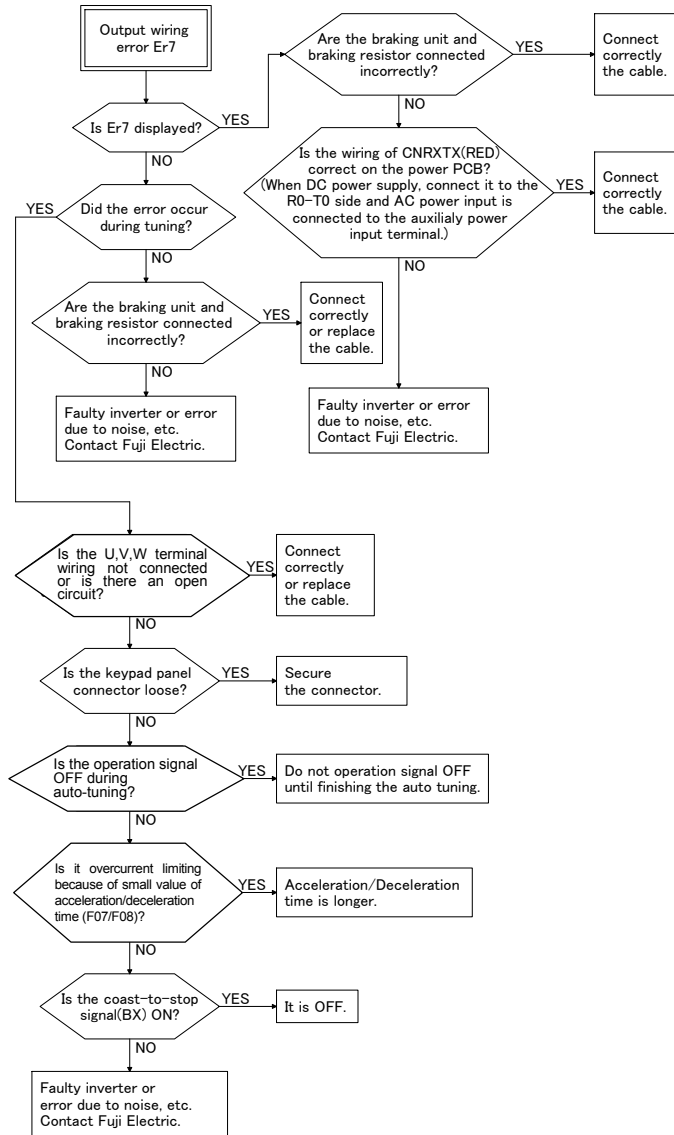

(11) Input phase loss

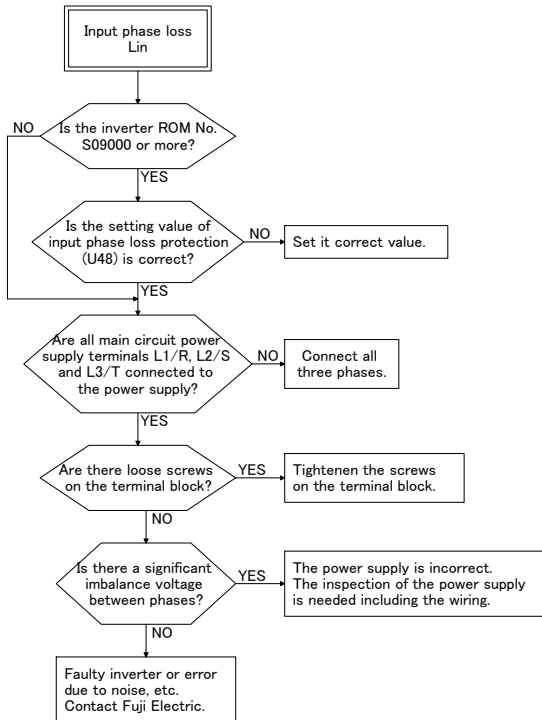

(12) Charging circuit error

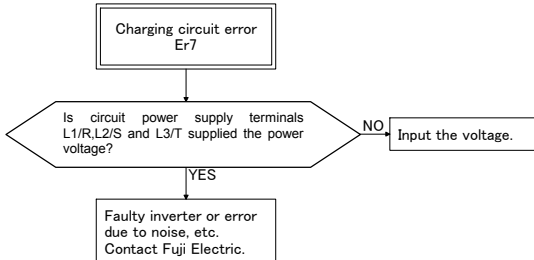

7-2 Abnormal motor rotation

(1) If motor does not rotate

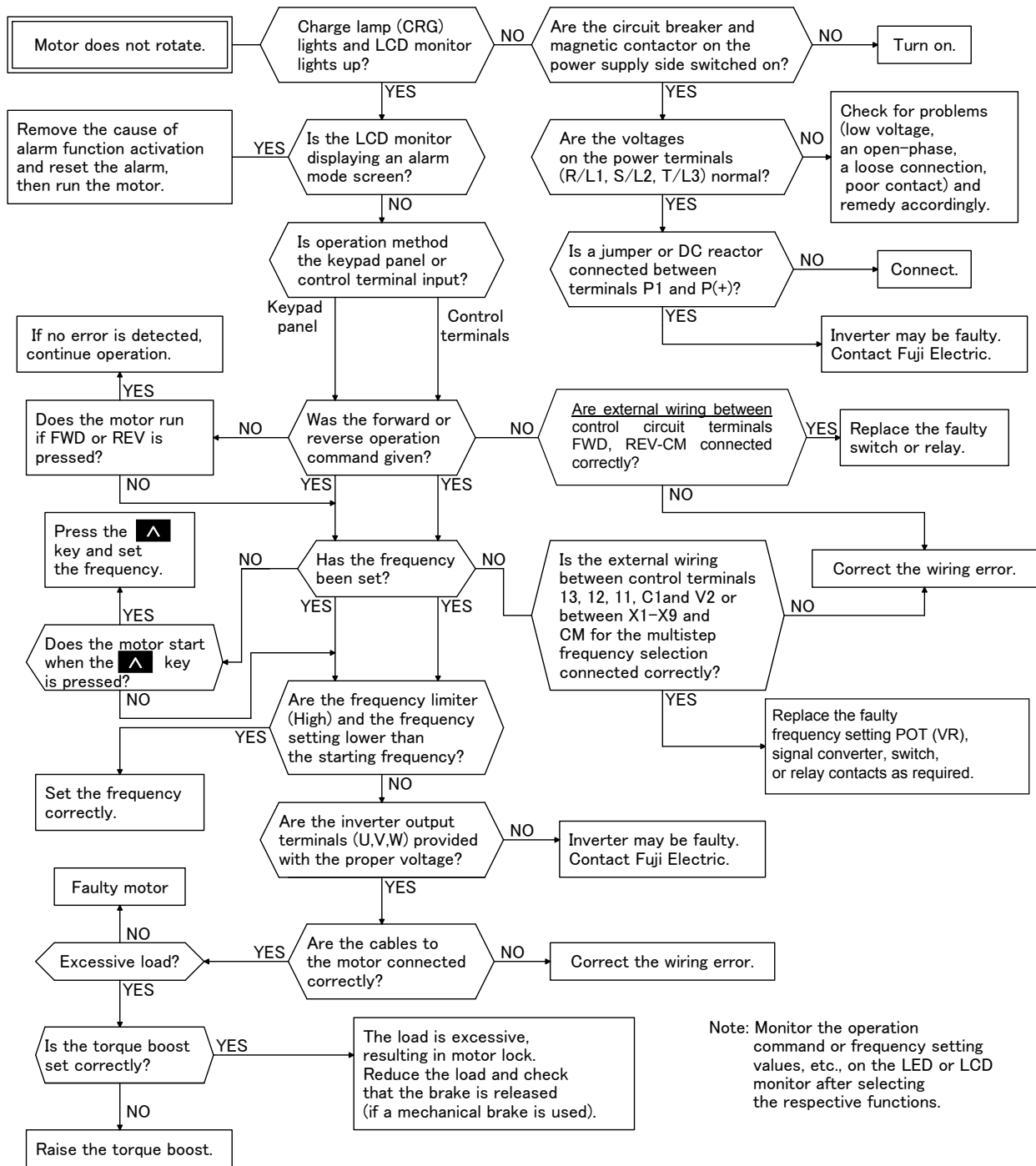

The motor does not rotate if the following commands are issued.

- An operation command is issued while the coast-to-stop or DC braking command is output
- A reverse operation command is issued with the “H08 Rev. phase sequence lock” value set to 1.

(2) If the motor rotates but the speed does not change

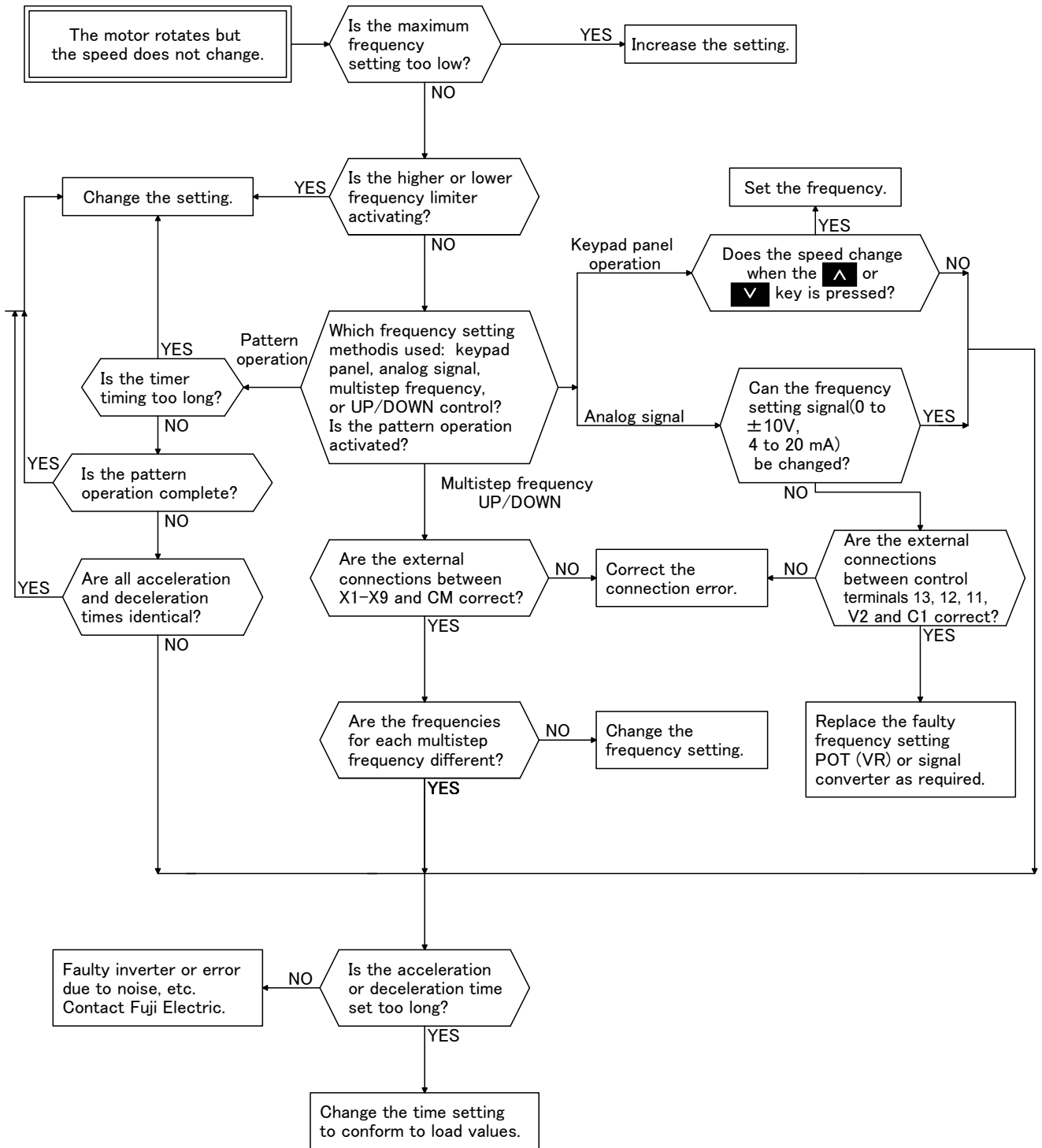

In the following cases, changing the motor speed is also restricted:

- Signals are input from control terminals both 12 and C1 when “F01 Frequency command 1” and “C30 Frequency command 2” are set to 3, and there is no significant change in the added value
- The load is excessive, and the torque limiting and current limiting functions are activated

(3) If the motor stalls during acceleration

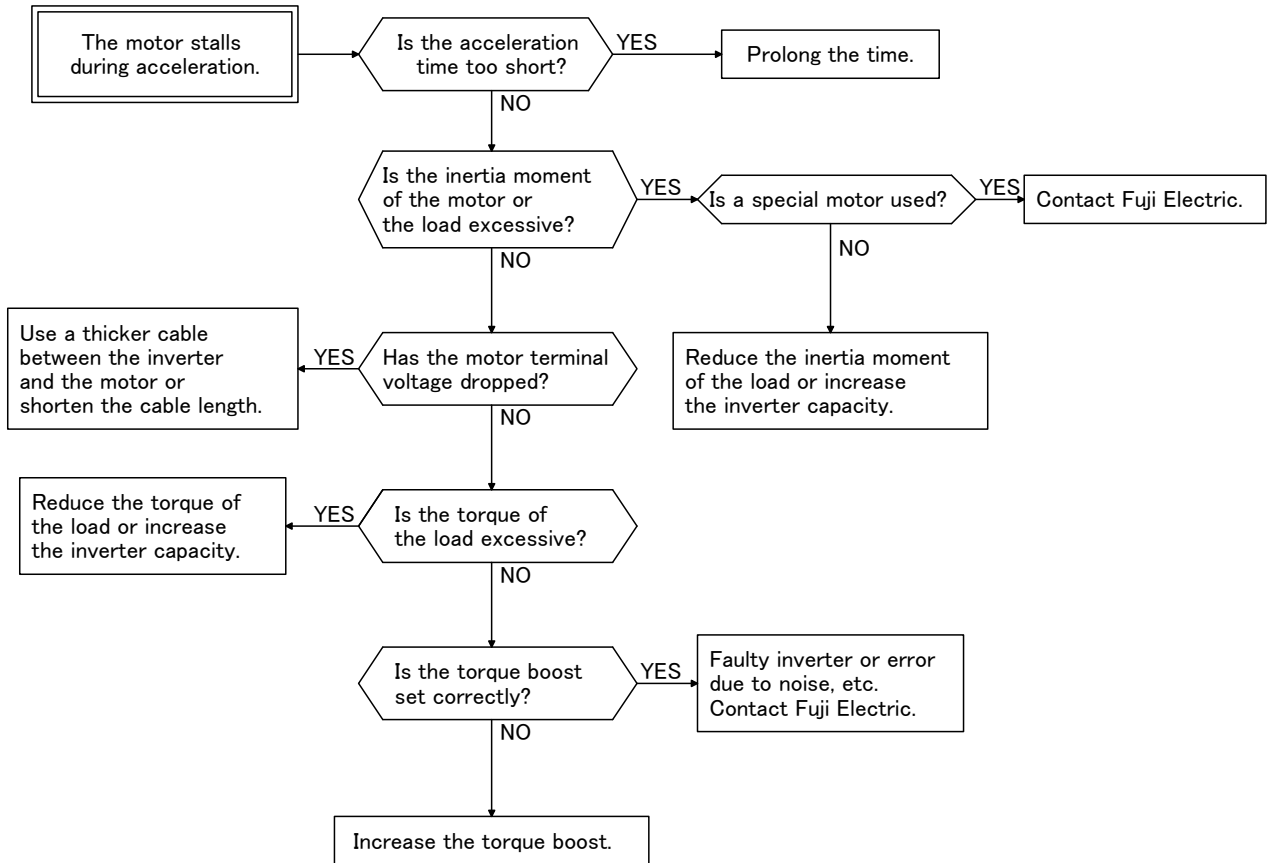

(4) If the motor generates abnormal heat

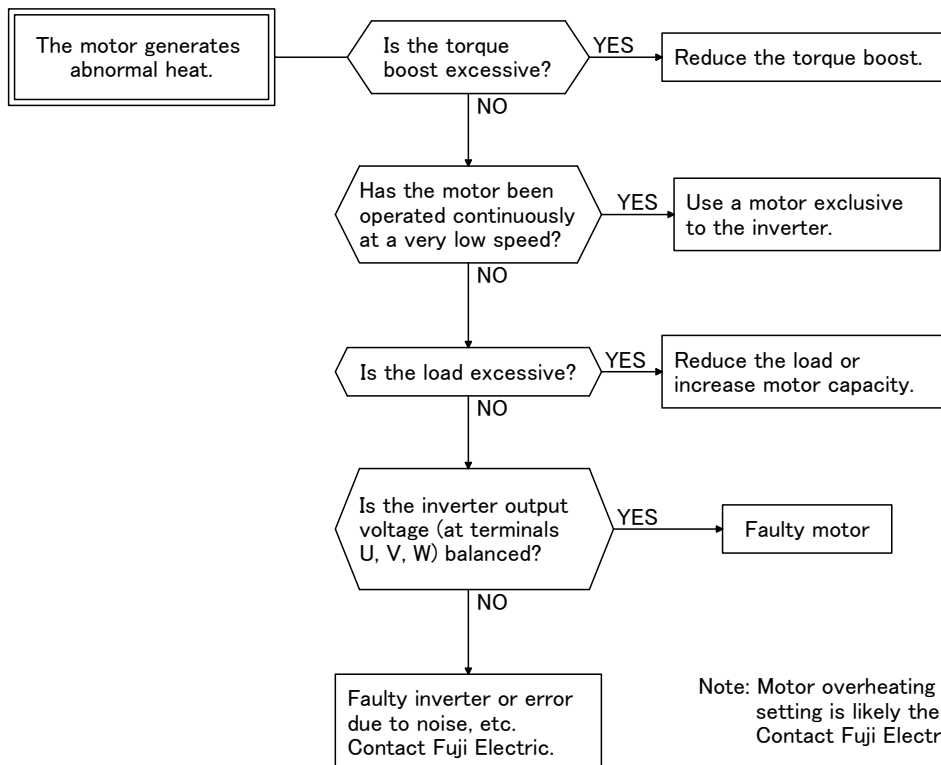

Note: Motor overheating following a higher frequency setting is likely the result of current waveform. Contact Fuji Electric.

8. Maintenance and Inspection

Proceed with daily inspection and periodic inspection to prevent malfunction and ensure long-term reliability. Note the following:

8-1 Daily Inspection

During operation, a visual inspection for abnormal operation is completed externally without removing the covers

The inspections usually cover the following:

- (1) The performance (satisfying the standard specification) is as expected.
- (2) The environment satisfies standard specifications.
- (3) The keypad panel display is normal.
- (4) There are no abnormal sounds, vibrations, or odors.
- (5) There are no indications of overheating or no discoloration.

8-2 Periodical Inspection

Periodic inspections must be completed after stopping operations, cutting off the power source, and removing the surface cover.

Note that after turning off the power, the smoothing capacitors in the DC section in the main circuit take time to discharge. To prevent electric shock, confirm using a multimeter that the voltage has dropped below the safety value (25 V DC or below) after the charge lamp (CRG) goes off.

 WARNING	<ul style="list-style-type: none"> • Start the inspection at least five minutes after turning off the power supply for inverter rated at 30HP or less, and ten minutes for inverter rated at 40HP or more. (Check that the charge lamp (CRG) goes off, and that the voltage is 25V DC or less between terminals P(+) and N(-). Electric shock may result. • Only authorized personnel should perform maintenance and component replacement operations. (Remove metal jewelry such as watches and rings.) (Use insulated tools.) • Never modify the inverter. Electric shock or injury may result.
--	--

Table 8-2-1 Periodical inspection list

Check parts	Check items	How to inspect	Evaluation Criteria	
Environment	<ol style="list-style-type: none"> 1) Check the ambient temperature, humidity, vibration, atmosphere (dust, gas, oil mist, water drops). 2) Is the area surrounding the equipment clear of foreign objects. 	<ol style="list-style-type: none"> 1) Conduct visual inspection and use the meter. 2) Visual inspection 	<ol style="list-style-type: none"> 1) The specified standard value must be satisfied. 2) The area is clear. 	
Keypad panel	<ol style="list-style-type: none"> 1) Is the display hard to read? 2) Are the characters complete? 	1),2) Visual inspection	1),2) The display can be read and is not abnormal.	
Structure such as a frame or cover	<ol style="list-style-type: none"> 1) Is there abnormal sound or vibration? 2) Are nuts or bolts loose? 3) Is there deformation or damage? 4) Is there discoloration as a result of overheating? 5) Are there stains or dust? 	<ol style="list-style-type: none"> 1) Visual and aural inspection 2) Tighten. 3),4),5) Visual inspection 	1), 2), 3), 4), 5) Not abnormal	
Main circuit	Common	<ol style="list-style-type: none"> 1) Are there loose or missing nuts or bolts? 2) Are there deformation, cracks, damage, and discoloration due to overheating or deterioration in the equipment and insulation? 3) Are there stains and dust? 	<ol style="list-style-type: none"> 1) Tighten. 2),3) Visual inspection 	1), 2), 3) Not abnormal Note: Discoloration of the bus bar does not indicate a problem.
	Conductor and wire	<ol style="list-style-type: none"> 1) Is there discoloration or distortion of a conductor due to overheating? 2) Are there cracks, crazing or discoloration of the cable sheath? 	1),2) Visual inspection	1), 2) Not abnormal

Main circuit	Terminal block	Is there damage?	Visual inspection	Not abnormal
	Smoothing capacitor	1) Is there electrolyte leakage, discoloration, crazing, or swelling of the case? 2) Is the safety valve not protruding or are valves protruding too far? 3) Measure the capacitance if necessary.	1), 2) Visual inspection 3) * Estimate life expectancy from maintenance information and from measurements using capacitance measuring equipment.	1), 2) Not abnormal 3) Capacitance \geq initial value x 0.85
Main circuit	Resistor	1) Is there unusual odor or damage to the insulation by overheating? 2) Is there an open circuit?	1) Visual and olfactory inspection 2) Conduct a visual inspection or use a multimeter by removing the connection on one side.	1) Not abnormal 2) Less than about $\pm 10\%$ of the indicated resistance value
	Transformer and reactor	Is there abnormal buzzing or an unpleasant smell?	Aural, olfactory, and visual inspection	Not abnormal
	Magnetic conductor and relay	1) Is there rattling during operation? 2) Are the contacts rough?	1) Aural inspection 2) Visual inspection	1),2)Not abnormal
Control circuit	Control PC board and connector	1) Are there any loose screws or connectors? 2) Is there an unusual odor or discoloration? 3) Are there cracks, damage, deformation, or excessive rust? 4) Is there electrolyte leakage or damage to the capacitor?	1) Tighten. 2) Visual and olfactory inspection 3) Visual inspection 4) * Estimate life expectancy by visual inspection and maintenance information	1),2),3),4)Not abnormal
Cooling system	Cooling fan	1) Is there abnormal sound or vibration? 2) Are nuts or bolts loose? 3) Is there discoloration due to overheating?	1)Aural and visual inspection. Turn manually (confirm the power is off). 2) Tighten. 3) Visual inspection 4) * Estimate life expectancy by maintenance information	1) The fan must rotate smoothly. 2), 3) Not abnormal
	Ventilation	Is there foreign matter on the heat sink or intake and exhaust ports?	Visual inspection	Not abnormal

Note: If equipment is stained, wipe with a clean cloth. Vacuum the dust.

***Estimation of life expectancy based on maintenance information**

The maintenance information is stored in the inverter keypad panel and indicates the electrostatic capacitance of the main circuit capacitors and the life expectancy of the electrolytic capacitors on the control PC board and of the cooling fans. Use this data as the basis to estimate the life expectancy of parts.

1) Determination of the capacitance of the main circuit capacitors

This inverter is equipped with a function to automatically indicate the capacitance of the capacitors installed in the main circuit when powering up the inverter again after disconnecting the power according to the prescribed conditions.

The initial capacitance values are set in the inverter when shipped from the factory, and the decrease ratio (%) to those values can be displayed.

Use this function as follows:

- (1) Remove any optional cards from the inverter. Also disconnect the DC bus connections to the main circuit P(+) and N(-) terminals from the braking unit or other inverters if connected. The existing power-factor correcting reactor (DC reactor) need not be disconnected. A power supply introduced to the auxiliary input terminals (R0, T0) that provides control power should be isolated.
- (2) Disable all the digital inputs (FWD, REV, X1-X9) on the control terminals. Also disconnect RS-485 communication if used. Turn on the main power supply. Confirm that the cooling fan is rotating and that the inverter is not operating. (There is no problem if the "OH2 External thermal relay tripped" trip function is activated due to the digital input terminal setting off.)
- (3) Turn the main power off.
- (4) Turn on the main power again after verifying that the charge lamp is completely off.
- (5) Open the maintenance information on the keypad panel and confirm the capacitance values of the built-in capacitors.

2) Life expectancy of the control PC board

The actual capacitance of a capacitor is not measured in this case. However, the integrated operating hours of the control power supply multiplied by the life expectancy coefficient defined by the temperature inside the inverter will be displayed. Hence, the hours displayed may not agree with the actual operating hours depending on the operational environment.

Since the integrated hours are counted by unit hours, power input for less than one hour will be disregarded.

3) Life expectancy of cooling fan

The integrated operating hours of the cooling fan are displayed. Since the integrated hours are counted by unit hours, power input for less than one hour will be disregarded.

The displayed value should be considered as a rough estimate because the actual life of a cooling fan is influenced significantly by the temperature.

Table 8-2-2 Rough estimate of life expectancy using maintenance information

Parts	Level of judgment
Capacitor in main circuit	85% or less of the initial value
Electrolytic capacitor on control PC board	61,000 hours
Cooling fan	40,000 hours (5HP or less), 25,000 hours (Over 7.5HP) (*1)

*1 Estimated life expectancy of a ventilation-fan at inverter ambient temperature of 40°C (104°F)







8-3 Measurement of Main Circuit Electrical Quantity

The indicated values depend on the type of meter because the harmonic component is included in the voltage and current of the main circuit power (input) and the output (motor) side of the inverter. When measuring with a meter for commercial power frequency use, use the meters shown in Table 8.3.1.

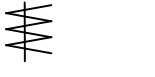
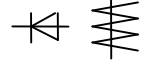
The power-factor cannot be measured using power-factor meters currently available on the market, which measure the phase difference between voltage and current. When power-factors must be measured, measure the power, voltage, and current on the input side and output side, then calculate the power-factor using the following formula:

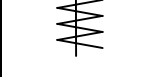
$$\text{Power factor} = \frac{\text{Power}[W]}{\sqrt{3} \times \text{Voltage}[V] \times \text{Current}[A]} \times 100[\%]$$

Table 8-3-1 Meters for measuring main circuit

Item	Input (power supply) side			Output (motor) side			DC link circuit voltage (P(+)-N(-))
	Voltage	Current*		Voltage	Current		
Meter name	Ammeter A _{R,S,T}	Voltmeter V _{R,S,T}	Powermeter W _{R,S,T}	Ammeter A _{U,V,W}	Voltmeter V _{U,V,W}	Powermeter W _{U,V,W}	DC voltmeter V
Meter type	Moving-iron type	Rectifier or moving-iron type	Digital power meter	Moving-iron type	Rectifier type	Digital power meter	Moving-coil type
Symbol							

Note: When measuring the output voltage using a rectifier type meter, an error may occur. Use a digital AC power meter to ensure accuracy.

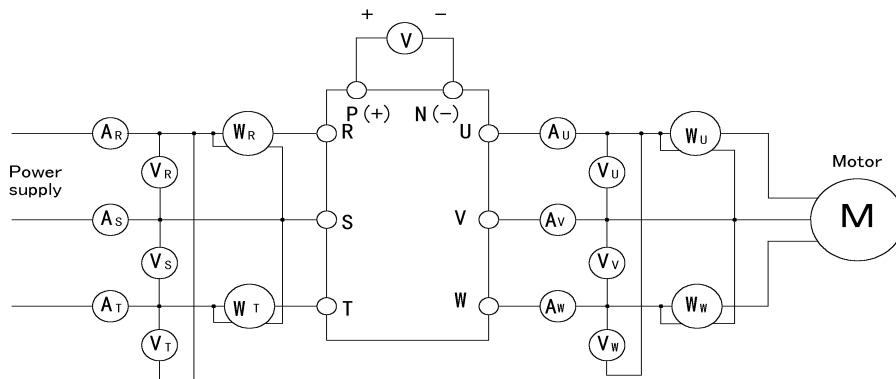

Fig 8-3-1 Connection of the meters

8-4 Insulation Test

Avoid testing an inverter with a megger because an insulation test is completed at the factory. If a megger test must be completed, proceed as described below. Use of an incorrect testing method may result in product damage.

If the specifications for the dielectric strength test are not followed, the inverter may be damaged. If a dielectric strength test must be completed, contact your local distributor or nearest Fuji Electric sales office.

(1) Megger test for the main circuit

- ① Use a 500V DC type megger and isolate the main power before commencing measurement.
- ② If the test voltage is connected to the control circuit, remove all connection cables to the control circuit.
- ③ Connect the main circuit terminals using common cables as shown in Fig. 8-4-1.
- ④ Execute the megger test only between the common cables connected to the main circuit and the ground (terminal \ominus G).
- ⑤ A megger indicating $5M\Omega$ or more is normal. (This is the value measured with an inverter only.)

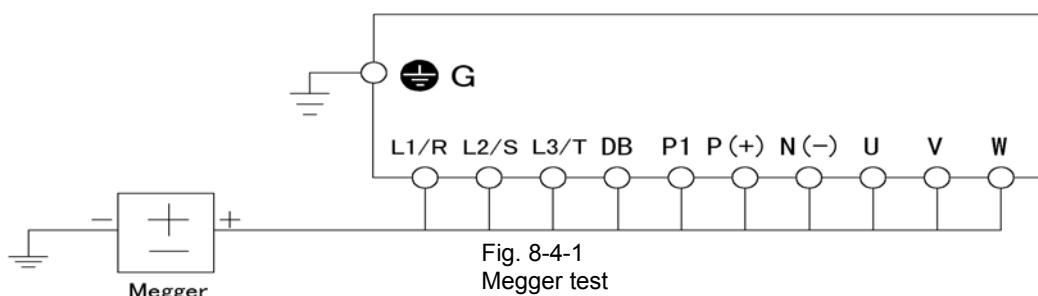

(2) Insulation test in the control circuit

A megger test and a dielectric strength test must not be performed in the control circuit. Prepare a high resistance range multimeter for the control circuit.

- ① Remove all external cables from the control circuit terminals.
- ② Conduct a continuity test between grounds. A result of $1M\Omega$ or more is normal.

(3) Exterior main circuit and sequence control circuit

Remove all cables from inverter terminals to ensure the test voltage is not applied to the inverter.

8-5 Parts Replacement

The life expectancy of a part depends on the type of part, the environment, and usage conditions. Parts should be replaced as shown in Table 8-5-1.

Table 8-5-1 Part replacement

Part name	Standard period for replacement	Comments
Cooling fan	3 years	Exchange for a new part.
Smoothing capacitor	5 years	Exchange for a new part (determine after checking).
Electrolytic capacitor on the PC board	7 years	Exchange for a new PC board (determine after checking).
Fuse	10 years	Exchange for a new part.
Other parts	—	Determine after checking.

8-6 Inquiries about Products and Product Guarantee

(1) Inquiries

If there is damage, a fault in the product, or questions concerning the product, contact your local distributor or nearest Fuji Electric sales office:

- a) Inverter type
- b) Serial No. (equipment serial number)
- c) Purchase date
- d) Inquiry details (e.g., damaged part, extent of damage, questions, status of fault)

(2) **Product guarantee --- Please take the following items into consideration when placing your order.**

When requesting an estimate and placing your orders for the products included in these materials, please be aware that any items such as specifications which are not specifically mentioned in the contract, catalog, specifications or other materials will be as mentioned below.

In addition, the products included in these materials are limited in the use they are put to and the place where they can be used, etc., and may require periodic inspection. Please confirm these points with your sales representative or directly with this company.

Furthermore, regarding purchased products and delivered products, we request that you take adequate consideration of the necessity of rapid receiving inspections and of product management and maintenance even before receiving your products.

1. Free of Charge Warranty Period and Warranty Range

1-1 Free of charge warranty period

- (1) The product warranty period is "1 year from the date of purchase" or 24 month from the manufacturing date imprinted on the name place, whichever date is earlier.
- (2) However in cases where the use environment, conditions of use, use frequency and times, etc., have an effect on product life, this warranty period may not apply.
- (3) Furthermore, the warranty period for parts restored by Fuji Electric's Service Department is "6 month from the date that repairs are completed."

1-2 Warranty range

- (1) In the event that breakdown occurs during the product's warranty period which is the responsibility of Fuji Electric, Fuji Electric will replace or repair the part of the product that has broken down free of charge at the place where the product was purchased or where it was delivered. However, if the following cases are applicable, the terms of this warranty may not apply.
 - 1) The breakdown was caused by inappropriate conditions, environment, handling or use methods, etc. which are not specified in the catalog, operation manual, specifications or other relevant documents.
 - 2) The breakdown was caused by the product other than the purchased or delivered Fuji's product.
 - 3) The breakdown was caused by the product other than Fuji's product, such as the customer's equipment or software design etc.
 - 4) Concerning the Fuji's programmable products, the breakdown was caused by a program other than a program supplied by this company, or the results from using such a program.
 - 5) The breakdown was caused by modifications or repairs affected by a party other than Fuji Electric.
 - 6) The breakdown was caused by improper maintenance or replacement using consumables, etc. specified in the operation manual or catalog, etc.
 - 7) The breakdown was caused by a chemical or technical problem that was not foreseen when making practical application of the product at the time it was purchased or delivered.
 - 8) The product was not used in the manner the product was originally intended to be used.
 - 9) The breakdown was caused by a reason which is not this company's responsibility, such as lightning or other disaster.
- (2) Furthermore, the warranty specified herein shall be limited to the purchased or delivered product alone.
- (3) The upper limit for the warranty range shall be as specified in item (1) above and any damages (damage to or loss of machinery or equipment, or lost profits from the same, etc.) consequent to or resulting from breakdown of the purchased or delivered product shall be excluded from coverage by this warranty.

1-3. Trouble diagnosis

As a rule, the customer is requested to carry out a preliminary trouble diagnosis. However, at the customer's request, this company or its service network can perform the trouble diagnosis on a chargeable basis. In this case, the customer is asked to assume the burden for charges levied in accordance with this company's fee schedule.

2. Exclusion of Liability for Loss of Opportunity, etc.

Regardless of whether a breakdown occurs during or after the free of charge warranty period, this company shall not be liable for any loss of opportunity, loss of profits, or damages arising from special circumstances, secondary damages, accident compensation to another company, or damages to products other than this company's products, whether foreseen or not by this company, which this company is not be responsible for causing.

3. Repair Period after Production Stop, Spare Parts Supply Period (Holding Period)

Concerning models (products) which have gone out of production, this company will perform repairs for a period of 7 years after production stop, counting from the month and year when the production stop occurs. In addition, we will continue to supply the spare parts required for repairs for a period of 7 years, counting from the month and year when the production stop occurs. However, if it is estimated that the life cycle of certain electronic and other parts is short and it will be difficult to produce or produce those parts, there may be causes where it is difficult to provide repairs or supply spare parts even within this 7-year period. For details, please confirm at our company's business office or our service office.

4. Transfer Rights

In the case of standard products which do not include settings or adjustments in an application program, the products shall be transported to and transferred to the customer and this company shall not be responsible for local adjustments or trial operation.

5. Service Contents

The cost of purchased and delivered products does not include the cost of dispatching engineers or service costs. Depending on the request, these can be discussed separately.

6. Applicable Scope of Service

Above contents shall be assumed to apply to transactions and use of the country where you purchased the products. Consult the local supplier or Fuji for detail separately.

9. Specifications

9-1 Standard Specifications

(1) Three-phase 230V series

Nominal applied motor [HP]		0.25	0.5	1	2	3	5	7.5	10	15	20	25	30	40	50	60	75	100	125	150		
G11	Type FRN□□□G11S-2UX	F25	F50	001	002	003	005	007	010	015	020	025	030	040	050	060	075	100	125	-		
	Rated output capacity (*1) [kVA]	0.6	1.2	2.0	3.2	4.4	6.8	10	13	18	24	29	35	46	58	72	86	113	138	-		
	Rated output current (*2) [A]	1.5	3.0	5.0	8.0	11	17	25	33	46	59	74	87	115	145	180	215	283	346	-		
	Overload capability	150% of rated output current for 1 min. 200% of rated output current for 0.5 s												150% of rated output current for 1 min. 180% of rated output current for 0.5 s								
	Starting torque	200% or more (under torque vector control)												180% or more (under torque vector control)								
	Braking torque (*3) [%]	150% or more			100% or more					Approx. 20%				Approx. 10 to 15%								
	Braking time [s]	10	5			5					No limit											
	Braking duty cycle [%ED]	10	5	3	5	3	2	3	2	No limit												
	Mass [lbs (kg)]	4.9 (2.2)	4.9 (2.2)	5.5 (2.5)	8.4 (3.8)	8.4 (3.8)	8.4 (3.8)	13 (6.1)	13 (6.1)	22 (10)	22 (10)	23 (10.5)	23 (10.5)	64 (29)	79 (36)	97 (44)	101 (46)	154 (70)	254 (115)	-		
P11	Type FRN□□□P11S-2UX	-	-	-	-	-	-	007	010	015	020	025	030	040	050	060	075	100	125	150		
	Rated capacity (*1) [kVA]	-	-	-	-	-	-	8.8	12	17	22	27	31	46	58	72	86	113	138	165		
	Rated output current (*2) [A]	-	-	-	-	-	-	22	29	42	55	67	78	115	145	180	215	283	346	415		
	Overload capability	110% of rated output current for 1 min.																				
	Starting torque	50% or more																				
	Braking torque (*3) [%]	Approx. 20%												Approx. 10 to 15%								
	Braking time [s]	No limit																				
	Braking duty cycle [%ED]	No limit																				
	Mass [lbs (kg)]	-	-	-	-	-	-	13 (5.7)	13 (5.7)	13 (5.7)	22 (10)	22 (10)	23 (10.5)	64 (29)	64 (29)	79 (36)	97 (44)	101 (46)	154 (70)	254 (115)		
Output ratings	Rated output voltage (*4) [V]	3-phase, 200V/50Hz, 200V,220V,230V/60Hz																				
	Rated output frequency [Hz]	50,60Hz																				
Input ratings	Phases, voltage, frequency	3-phase, 200 to 230V, 50/60Hz												3-phase, 200 to 220V, 220 to 230V/50Hz 3-phase, 200 to 230V/60Hz								
	Voltage/frequency variations	Voltage: +10% to -15% (Imbalance rate between phases: 2% or less (*6) , Frequency: +5% to -5%																				
	Momentary voltage dip capability (*7)	Operation will continue with 165V or more. If voltage drops below 165V, operation will continue for up to 15 ms. If "Continuous operation" is selected, the output frequency will be lowered to withstand the load until normal voltage is resumed.																				
	Required power supply capacity (*8)[kVA]	0.4	0.7	1.3	2.2	3.1	5.0	7.2	9.7	15	20	24	29	38	47	56	69	93	111	134		

(2) Three-phase 460V series

Nominal applied motor [HP]		0.5	1	2	3	5	7.5	10	15	20	25	30	40	50	60	75	100	125	150	200	250	300	350	400	450	500	600	700	800
G11	Type FRN□□□G11S-4UX	F50	001	002	003	005	007	010	015	020	025	030	040	050	060	075	100	125	150	200	250	300	350	400	450	500	600	-	-
	Rated output capacity (*1) [kVA]	1.2	2.0	2.9	4.4	7.2	10	14	19	24	31	36	48	60	73	89	120	140	167	202	242	300	331	414	466	518	590	-	-
	Rated output current (*2) [A]	1.5	2.5	3.7	5.5	9	13	18	24	30	39	45	60	75	91	112	150	176	210	253	304	377	415	520	585	650	740	-	-
	Overload capability	150% of rated output current for 1 min. 200% of rated output current for 0.5 s												150% of rated output current for 1 min. 180% of rated output current for 0.5 s															
	Starting torque	200% or more (under torque vector control)												180% or more (under torque vector control)															
	Braking torque (*3) [%]	50% or more			100% or more				20% or more					10 to 15%															
	Braking time [s]	5			5				No limit																				
	Braking duty cycle [%ED]	5	3	5	3	2	3	2	No limit																				
Mass [lbs (kg)]	4.9 (2.2)	5.5 (2.5)	8.4 (3.8)	8.4 (3.8)	8.4 (3.8)	14 (6.5)	14 (6.5)	22 (10)	22 (10)	23 (10.5)	23 (10.5)	64 (29)	75 (34)	86 (39)	88 (40)	106 (48)	154 (70)	154 (70)	220 (100)	220 (100)	309 (140)	309 (140)	705 (320)	705 (320)	904 (410)	904 (410)	-	-	
P11	Type FRN□□□P11S-4UX	-	-	-	-	-	007	010	015	020	025	030	040	050	060	075	100	125	150	200	250	300	350	400	450	500	600	700	800
	Rated capacity (*1) [kVA]	-	-	-	-	-	10	13	18	24	29	35	48	60	73	89	120	140	167	202	242	300	331	386	414	518	590	669	765
	Rated output current (*2) [A]	-	-	-	-	-	12.5	16.5	23	30	37	44	60	75	91	112	150	176	210	253	304	377	415	485	520	650	740	840	960
	Overload capability	110% of rated output current for 1 min.																											
	Starting torque	50% or more																											
	Braking torque (*3) [%]	Approx. 20%												Approx. 10 to 15%															
	Braking time [s]	No limit																											
	Braking duty cycle [%ED]	No limit																											
Mass [lbs (kg)]	-	-	-	-	-	13 (6.1)	13 (6.1)	13 (6.1)	22 (10)	22 (10)	23 (10.5)	64 (29)	64 (29)	75 (34)	86 (39)	88 (40)	106 (48)	154 (70)	154 (70)	220 (100)	220 (100)	309 (140)	309 (140)	309 (140)	705 (320)	705 (320)	904 (410)	904 (410)	
Output ratings	Rated output voltage(*4) [V]	3-phase, 380V, 400V, 415V(440V)/50Hz, 380V, 400V, 440V, 460V/60Hz																											
	Rated output frequency [Hz]	50,60Hz																											
Input ratings	Phases, voltage, frequency	3-phase,380 to 480V,50/60Hz												3-phase, 380 to 440V/50Hz *5) 3-phase, 380 to 480V/60Hz															
	Voltage/frequency variations	Voltage: +10% to -15% (Imbalance rate between phases: 2% or less (*6) , Frequency: +5% to -5%																											
	Momentary voltage dip capability (*7)	Operation will continue with 310V or more. If voltage drops below 310V, operation will continue for up to 15 ms. If "Continuous operation" is selected, the output frequency will be lowered to withstand the load until normal voltage is resumed.																											
	Required power supply capacity (*8)[kVA]	0.7	1.2	2.2	3.1	5.0	7.2	9.7	15	20	24	29	38	47	57	70	93	111	136	161	196	244	267	341	383	433	488	549	610

(*1) Indicated capacities are at the rated output voltage 230V for the 230V series and 460V for the 460V series. The rated capacity will be lowered if the supply voltage is lowered.

(*2) In the case of a low impedance load, such as a high-frequency motor, the current may drop below the rated current.

(*3) Indicates when a nominal applied motor is used (the average torque when decelerated to stoppage from 60 Hz, which varies depending on motor loss).

(*4) An output voltage exceeding the supply voltage cannot be generated.

(*5) The taps within the inverter must be changed for a power supply rated at 380 to 398V/50 Hz or 380 to 430V/60 Hz.

(*6) If the imbalance between phases exceeds 2%, use a power-factor correcting DC reactor (DCR).

$$\text{Imbalance rate between phases [\%]} = \frac{(\text{Max. Voltage [V]} - \text{Min. Voltage [V]})}{3\text{-phase average voltage [V]}} \times 67[\%]$$

(*7) Test was conducted under the standard load conditions stipulated by the JEMA committee (at the load equivalent to 85% of the nominal applied motor).

(*8) Indicates the values required when using a power-factor correcting DC reactor (DCR) (optional for inverters of 75HP or less) with a loaded nominal applied motor.

9-2 Common Specifications

Item		Explanation	
Control	Control method	Sinusoidal wave PWM control (with V/F control, torque vector control, PG feedback vector control (option))	
	Output frequency	Maximum frequency	G11S: 50 to 400Hz variable setting P11S: 50-120Hz variable setting
		Base frequency	G11S: 25 to 400Hz variable setting P11S: 25-120Hz variable setting
		Starting frequency	0.1 to 60Hz variable setting Holding time: 0.0 to 10.0 s
		Carrier frequency	G11: 0.75 to 15kHz (75HP or less) 0.75 to 10kHz (100HP or more) P11: 0.75 to 15kHz (30HP or less) 0.75 to 10kHz (40 to 100HP) 0.75 to 6kHz (125HP or more)
		Accuracy (stability)	Analog setting: +/- 0.2% or less of the max. Frequency (at 25°C (77°F) +/- 10°C (50°F)) Digital setting: +/- 0.01% or less of the max. Frequency (-10°C (14°F) to +5°C (122°F))
		Setting resolution	Analog setting: 1/1000 of max. frequency (30HP or less) 1/3000 of max. frequency (40HP or more) Digital setting: 0.01Hz (99.99Hz or less), 0.1Hz (100.0Hz or more)
	Voltage/frequency characteristics	Output voltage at base frequency can be adjusted separately, such as 80 to 240V (230V series) or 320 to 480V (460V series). Output voltage at max. frequency can be adjusted separately, such as 80 to 240V (230V series) or 320 to 480V (460V series).	
	Torque boost	Auto: Optimum control corresponding to the load torque. Manual: 0.1 to 20.0 code setting (energy saving reduced torque, constant torque (strong), etc.)	
	Accelerating/decelerating time	0.01 to 3600s Four accelerating and decelerating time settings are possible independent of each other by selecting digital input signals. In addition to linear acceleration and deceleration, either S-shaped acceleration/deceleration (weak/strong) or curvilinear acceleration/deceleration can be selected.	
DC injection braking	Starting frequency: 0.0 to 60.0Hz, braking time: 0.0 to 30.0s, Braking level: 0 to 100% (G11S), 0-80% (P11S)		
Function equipped	Frequency upper and lower limiter, bias frequency, frequency gain, jump frequency, pick-up operation, restart after momentary power failure, switching operation from line to inverter, slip compensation control, automatic energy saving operation, regeneration avoiding control, droop control, torque limiting (2-step), torque control, PID control, second motor switching, cooling fan ON/OFF control.		
Operation	Operation method	Keypad panel: Run by FWD , REV keys, stop by STOP key Terminal input: Forward/stop command, reverse/stop command, coast-to-stop command, alarm reset, acceleration/deceleration selection, multistep frequency selection, etc.	
	Frequency setting	Keypad panel: Setting by ▲ , ▼ keys External potentiometer: External freq.setting POT (VR) (1 to 5kΩ) Analog input: 0 to +10V (0 to +5V), 4 to 20mA, 0 to +/- 10V (FWD/REV operation) +10 V to 0 (reverse operation), 20 to 4mA (reverse operation) UP/DOWN control: Frequency increases or decreases as long as the digital input signal is turned on. Multistep frequency selection: Up to 15 steps are selectable by a combination of digital input signals (four kinds). Link operation: Operation by RS-485 (standard). Program operation: Pattern operation by program Jogging operation: Jogging operation by FWD , REV key or digital input signals	
	Operation status signal	Transistor output (4 signals): Running, frequency arrival, frequency detection, overload early warning, etc. Relay output (2 signals): Alarm output (for any fault), multi-purpose relay output signals Analog output (1 signal): Output frequency, output current, output voltage, output torque, power consumption, etc. Pulse output (1 signal): Output frequency, output current, output power, output torque, power consumption, etc.	
Indication	Digital display (LED)	Output frequency, setting frequency, output current, output voltage, motor synchronous speed, line speed, load rotation speed, calculated torque value, power consumption, calculated PID value, PID command value, PID feedback value, alarm code	
	Liquid crystal display (LCD)	Operation information, operational guide, functional code/name/setting data, alarm information, tester function, motor load rate measuring function (Maximum/average current (rms) during measuring period, maintenance information (Integrated operation hours, capacitance measurement for main circuit capacitors, heat sink temperature, etc.))	
	Language	Six languages (Japanese, English, German, French, Spanish, and Italian)	
	Lamp display	Charging (voltage residual), operation indication	
Protective functions		Overcurrent, short-circuit, ground fault, overvoltage, undervoltage, overload, overheating, blown fuse, motor overload, external alarm, input open-phase, output open-phase (when tuning), braking resistor protection, CPU and memory error, keypad panel communication error, PTC thermistor protection, surge protection, stall prevention, etc.	
Environment	Installation location	Indoor, altitude less than 3300ft (1000m), free from corrosive gas, dust, and direct sunlight (Pollution degree 2)	
	Ambient temperature	-10°C (14°F) to +50°C (122°F) (ventilating cover must be removed under conditions exceeding +40°C (104°F) for models rated at 30HP or less)	
	Ambient humidity	5 to 95%RH (no condensation)	
	Air pressure	Operation/storage :86 to 106 kPa Transport :70 to 106 kPa	
	Vibration	0.12inch(3mm) at from 2 to less than 9Hz, 9.8m/s ² at from 9 to less than 20Hz, 2m/s ² at from 20 to less than 55Hz, 1m/s ² at from 55 to less than 200Hz,	
	Storage	Ambient temperature: -25°C (-13°F) to +65°C (149°F) Ambient humidity: 5 to 95%RH (no condensation)	

9-3 Outline Dimensions

■ Outline Dimensions (30HP or less)

inch (mm)

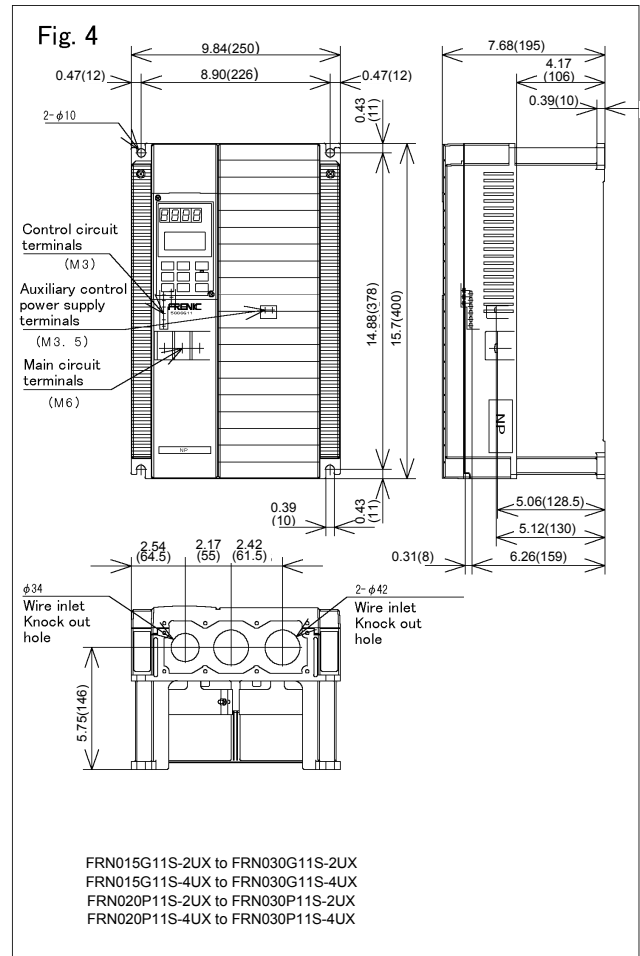
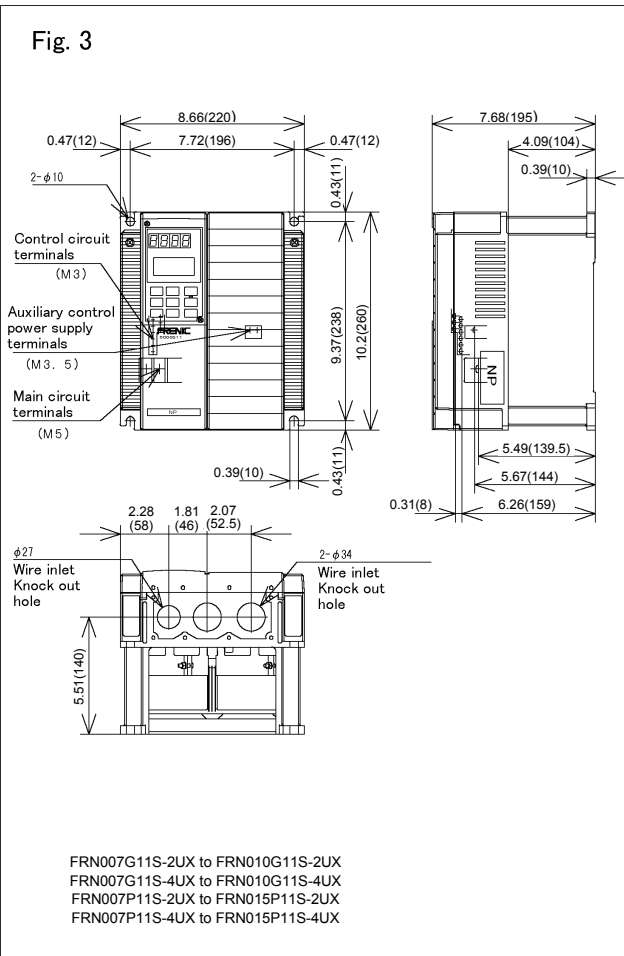
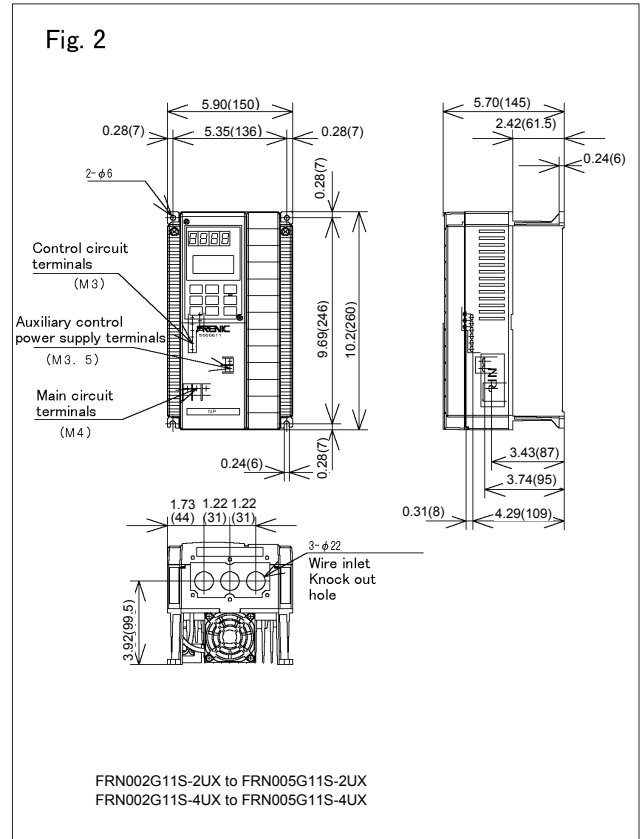
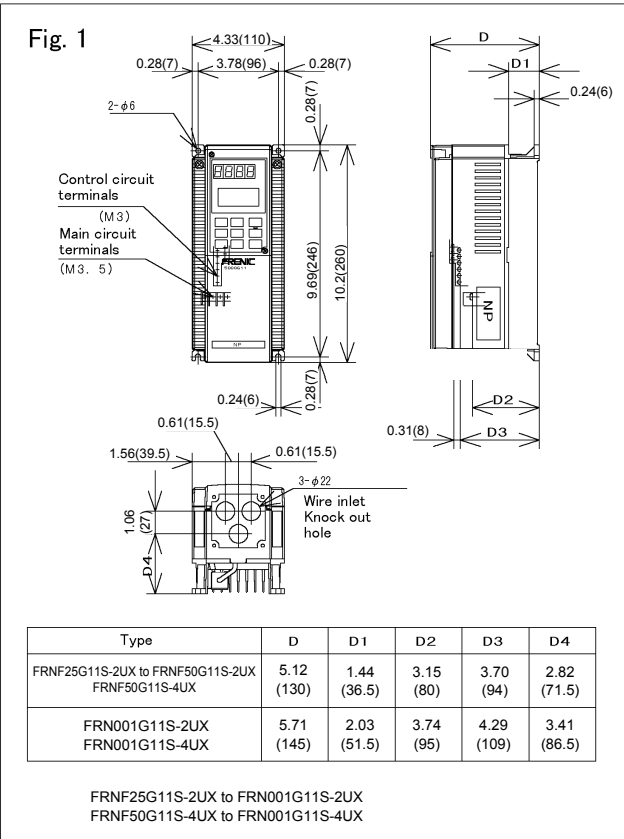

■ Outline Dimensions (G11S :40HP to 350HP, P11S :40HP to 450HP)

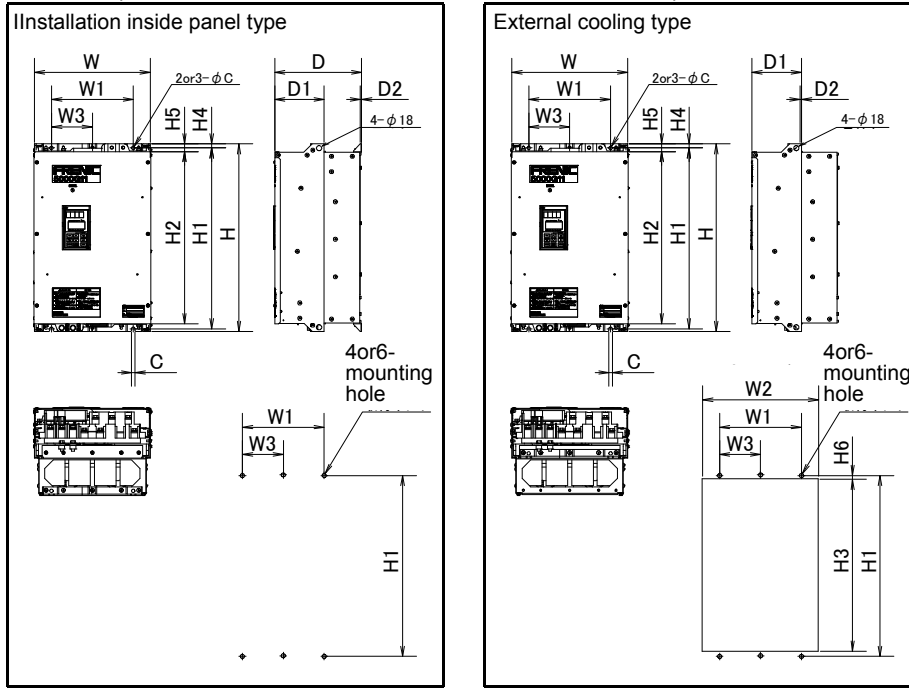

230V Series

Nominal applied motor[HP]	Inverter type		Dimension											Unit inch (mm)				Mounting bolt	
	FRN-G11S series	FRN-P11S series	W	W1	W2	W3	H	H1	H2	H3	H4	H5	H6	D	D1	D2	C		
40	FRN040G11S-2UX	FRN040P11S-2UX	13.4	9.45	12.8	-	21.7	20.9	19.7	20.2	0.47	0.98	0.35	10.0	5.71	0.39	M8		
50	-	FRN050P11S-2UX	(340)	(240)	(326)		24.2	23.4	22.2	22.7				10.6					
	FRN050G11S-2UX	-					(615)	(595)	(565)	(577)				(270)					
60	-	FRN060P11S-2UX	14.8	10.8	14.2		29.1	28.3	27.2	27.6	0.61	1.28	0.49	11.2	5.71	0.16		0.59	
	FRN060G11S-2UX	-					(375)	(275)	(361)	(740)									(720)
75	-	FRN075P11S-2UX					29.5	28.3	27.0	27.4									12.4
100	-	FRN100P11S-2UX	20.9	16.9	20.1		29.5	28.3	27.0	27.4	0.61	1.28	0.49	11.2	5.71	0.16		0.59	
	FRN100G11S-2UX	-					(530)	(430)	(510)	(750)									(720)
125	-	FRN125P11S-2UX					26.8	22.8	26.0	11.4									34.6
150	-	FRN150P11S-2UX	(680)	(580)	(660)		11.4	(290)	(880)	(850)	(815)	(825)							

460V Series

Nominal applied motor[HP]	Inverter type		Dimension											Unit inch (mm)				Mounting bolt
	FRN-G11S series	FRN-P11S series	W	W1	W2	W3	H	H1	H2	H3	H4	H5	H6	D	D1	D2	C	
40	FRN040G11S-4UX	FRN040P11S-4UX	13.4	9.45	12.8	-	21.7	20.9	19.7	20.2	0.47	0.98	0.35	10.0	5.71	0.39	M8	
50	-	FRN050P11S-4UX	(340)	(240)	(326)		26.6	25.8	24.6	25.1				10.6				
	FRN050G11S-4UX	-					(675)	(655)	(625)	(637)				(270)				
60	-	FRN060P11S-4UX	14.8	10.8	14.2		29.1	28.3	27.2	27.6	0.61	1.28	0.49	12.4	6.89	0.16		0.59
	FRN060G11S-4UX	-					(375)	(275)	(361)	(740)								
75	-	FRN075P11S-4UX					29.1	28.0	26.6	27.0								
100	-	FRN100P11S-4UX	20.9	16.9	20.1		29.1	28.0	26.6	27.0	0.61	1.28	0.49	12.4	6.89	0.16		0.59
	FRN100G11S-4UX	-					(530)	(430)	(510)	(740)								
125	-	FRN125P11S-4UX					29.1	28.0	26.6	27.0								
150	-	FRN150P11S-4UX	20.9	16.9	20.1		29.1	28.0	26.6	27.0	0.61	1.28	0.49	12.4	6.89	0.16		0.59
	FRN150G11S-4UX	-					(530)	(430)	(510)	(740)								
200	-	FRN200P11S-4UX					39.4	38.2	36.8	37.2								
250	-	FRN250P11S-4UX	26.8	22.8	26.0	39.4	38.2	36.8	37.2	0.61	1.28	0.49	14.2	8.66	0.16	0.59		
	FRN250G11S-4UX	-				(680)	(580)	(660)	(1000)								(970)	(935)
300	-	FRN300P11S-4UX				11.4	(290)	(880)	(850)								(815)	(825)
350	-	FRN350P11S-4UX	26.8	22.8	26.0	11.4	(290)	(880)	(850)	(815)	(825)							
	FRN350G11S-4UX	-																
400	-	FRN400P11S-4UX																
450	-	FRN450P11S-4UX																

■ Outline Dimensions (G11S :400HP or more ,P11S :500HP or more)

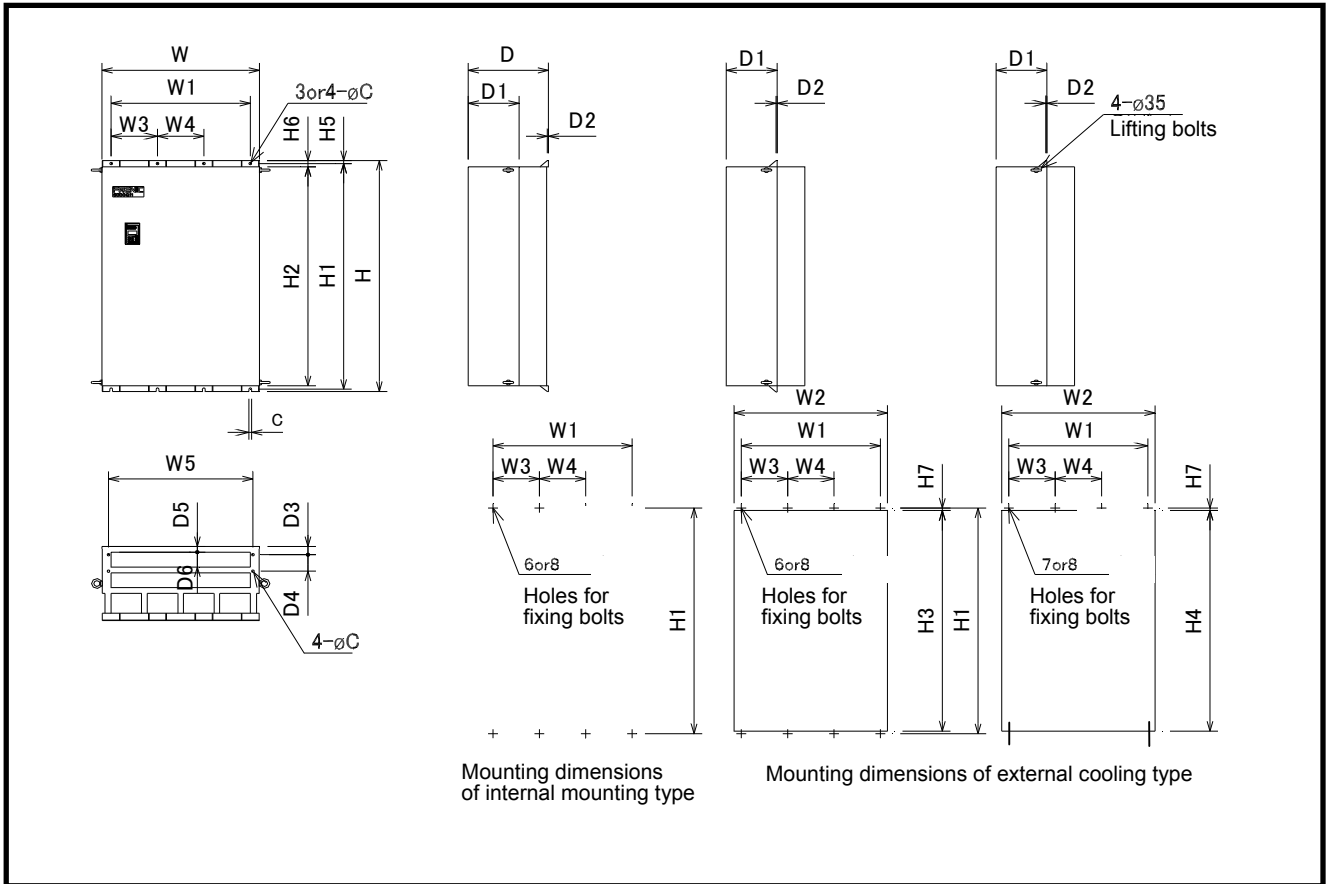

460V Series

Nominal applied motor[HP]	Inverter type		Dimension															
	FRN-G11S series	FRN-P11S series	W	W1	W2	W3	W4	W5	H	H1	H2	H3	H4	H5	H6	H7	D	D1
400	FRN400G11S-4UX																	
450	FRN450G11S-4UX		26.8 (680)	22.8 (580)	26.0 (660)	11.4 (290)	-	24.0 (610)										
500		FRN500P11S-4UX							55.1 (1400)	53.9 (1370)	52.4 (1330)	52.8 (1340)	52.6 (1335)	0.61 (15.5)	1.38 (35)	0.57 (14.5)	17.7 (450)	11.2 (285)
600		FRN600P11S-4UX																
500	FRN500G11S-4UX																	
600	FRN600G11S-4UX		34.6 (880)	30.7 (780)	33.9 (860)	10.2 (260)	10.2 (260)	31.9 (810)										
700		FRN700P11S-4UX																
800		FRN800P11S-4UX																

Nominal applied motor[HP]	Inverter type		Dimension							Mounting bolt
	FRN-G11S series	FRN-P11S series	D2	D3	D4	D5	D6	C		
400	FRN400G11S-4UX									
450	FRN450G11S-4UX	FRN450P11S-4UX								
500		FRN500P11S-4UX								
600		FRN600P11S-4UX	0.25 (6.4)	1.97 (50)	3.94 (100)	1.38 (35)	4.53 (115)	0.59 (15)	M12	
500	FRN500G11S-4UX									
600	FRN600G11S-4UX									
700		FRN700P11S-4UX								
800		FRN800P11S-4UX								

■ Outline Dimensions (Reactor; Accessories for 100HP or more)

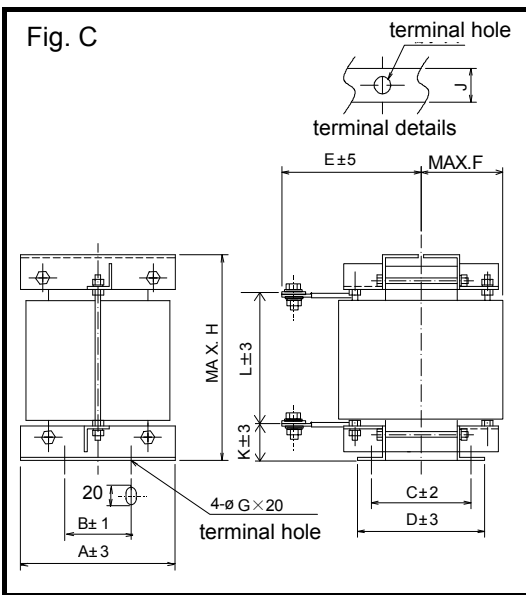
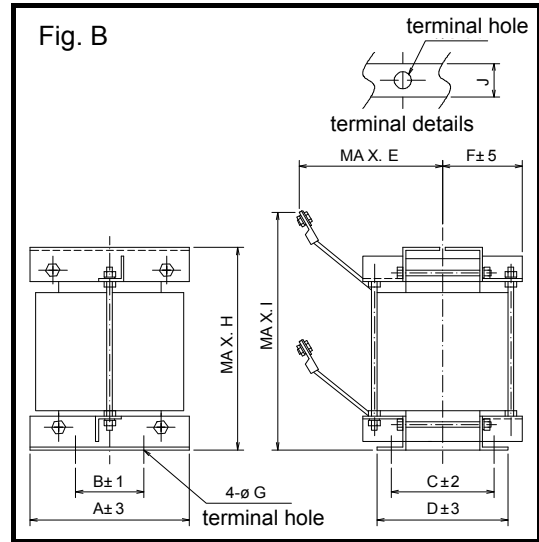
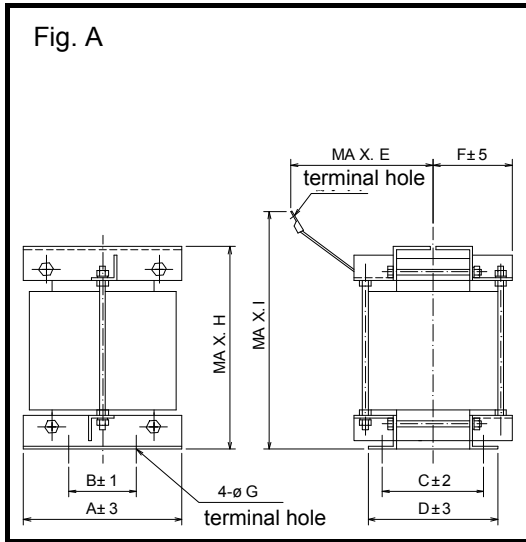

230V Series

Inverter type	DC Reactor type	Fig.	Dimension											Terminal hole size	Mass [lbs] (kg)	
			A	B	C	D	E	F	G	H	I	J	K			L
FRN100G11S/P11S-2UX	DCR2-75B	Fig. A	7.87 (200)	6.69 (170)	3.94 (100)	5.55 (141)	4.33 (110)	2.76 (70)	0.39 (10)	8.27 (210)	10.6 (270)	—	—	—	M12	40 (18)
FRN125G11S/P11S-2UX	DCR2-90B	Fig. B	7.09 (180)	5.91 (150)	4.33 (110)	5.94 (151)	5.51 (140)	2.95 (75)		9.45 (240)	11.0 (280)	0.98 (25)	—	—	φ 15	44 (20)
FRN150P11S-2UX	DCR2-110B		7.48 (190)	6.30 (160)	4.72 (120)	6.34 (161)	5.91 (150)	3.15 (80)		10.6 (270)	13.0 (330)	—	—	—	—	55 (25)

460V Series

Inverter type	DC Reactor type	Fig.	Dimension											Terminal hole size	Mass [lbs] (kg)		
			A	B	C	D	E	F	G	H	I	J	K			L	
FRN100G11S/P11S-4UX	DCR4-75B	Fig. A	7.48 (190)	6.30 (160)	4.53 (115)	5.94 (151)	3.94 (100)	2.95 (75)	0.39 (10)	9.45 (240)	10.6 (270)	—	—	—	M10	44 (20)	
FRN125G11S/P11S-4UX	DCR4-90B				4.92 (125)	6.34 (161)	4.72 (120)	3.15 (80)		9.84 (250)	11.0 (280)	0.98 (25)	—	—		φ 12	50 (23)
FRN150G11S/P11S-4UX	DCR4-110B				7.87 (200)	6.69 (170)				3.35 (85)	10.2 (260)	—	—	—			—
FRN200G11S/P11S-4UX	DCR4-132B	Fig. B	8.27 (210)	7.09 (180)	5.31 (135)	6.73 (171)	5.51 (140)	3.54 (90)	0.39 (10)	11.4 (290)	12.6 (320)	1.18 (30)	—	—	φ 15		71 (32)
FRN250G11S/P11S-4UX	DCR4-160B									11.6 (295)	13.0 (330)	—	—	77 (35)			
FRN300G11S/P11S-4UX	DCR4-200B									11.8 (300)	13.8 (350)	—	—			88 (40)	
FRN350G11S/P11S-4UX	DCR4-220B	Fig. C	8.66 (220)	7.48 (190)	5.71 (145)	7.13 (181)	5.91 (150)	3.74 (95)	0.47 (12)	14.6 (370)	—	—	—	φ 15	99 (45)		
FRN400G11S/P11S-4UX	DCR4-280B									12.6 (320)	—	1.61 (41)	8.46 (215)		115 (52)		
FRN450P11S-4UX	DCR4-315B									—	—	—	—		121 (55)		
FRN450G11S-4UX	DCR4-355B	Fig. C	9.45 (240)	8.27 (210)	5.71 (145)	7.13 (181)	6.30 (160)	3.74 (95)	0.47 (12)	—	—	—	—	φ 15	132 (60)		
FRN500G11S/P11S-4UX	DCR4-400B						6.69 (170)			—	—	—	148 (67)				
FRN600G11S/P11S-4UX	DCR4-450B						13.4 (340)			—	1.77 (45)	8.86 (225)	154 (70)				
FRN700P11S-4UX	DCR4-450B	Fig. C	10.2 (260)	8.86 (225)	5.71 (145)	7.13 (181)	7.28 (185)	3.94 (100)	0.47 (12)	—	—	1.97 (50)	—	φ 15	148 (67)		
FRN800P11S-4UX	DCR4-500B						—			—	—	—	154 (70)				

9-4 RS-485 Modbus RTU Serial Communications

The serial interface supports operation, configuration and monitoring of inverter functions through an EIA/RS-485 connection. The serial interface is based on Modbus RTU protocol. This protocol allows the inverter to function as an RTU slave on an industrial network.

9-4-1 Transmission Specification

Item	Specification
Physical level	EIA/RS-485
Transmission distance	1600 ft (500 m)
Number of nodes	32 total
Transmission speed	19200, 9600, 4800, 2400 [bits/s]
Transmission mode	Half duplex
Transmission protocol	Modbus RTU
Character code	Binary
Character length	8 bits
Error check	CRC

9-4-2 Connection

Connection method

Use shielded wire and connect to the control terminals (DX-, DX+ and SD). A termination resistor should be added between the data lines on the each end of the network. The value of the termination resistor depends on the characteristic impedance of the cable. A common value for termination resistors is 120 ohms.

Control terminals

Terminal marking	Terminal name	Function description
DX+	RS-485 communication data (+)	Input/output terminals for RS-485 communication.
DX-	RS-485 communication data (-)	
SD	Cable shield	Electrically floating

9-4-3 Serial Interface Configuration

Inverter function codes H30 to H39 are used to configure the serial interface parameters, such as device address, baud rate and error response.

9-4-4 Modbus RTU Functions

The following RTU functions are supported. The maximum number of consecutive parameters for function 03 and 16 messages is 16.

Code	Description
03	Read Holding Registers (16 registers maximum)
06	Preset Single Register
16	Preset Multiple Registers (16 registers maximum)

9-4-5 Inverter Function Code Access

All of the inverter function codes are accessible through the RS-485 serial interface. Inverter function codes are mapped to RTU holding registers. An inverter function code RTU address is 2 bytes in length. The high byte corresponds to a code that represents the inverter parameter sort (F–M). The low byte corresponds to the inverter parameter number within the sort (0 -99).

Code	Sort	Name	Code	Sort	Name
0	F	Basic function	5	A	Motor 2 function
1	E	Terminal function	6	o	Option function
2	C	Control function	7	S	Command/function data
3	P	Motor 1 function	8	M	Monitor data
4	H	High level function			

For example, inverter function code M11, output current, is addressed as RTU parameter number 080B hexadecimal or 2059 decimal.

high byte	low byte
inverter parameter sort code	inverter parameter number

9-4-6 Command and Monitor Data Registers

The command and monitor function codes are used to control the operation of the inverter and monitor the status variables through the serial interface. The command and monitor function codes are not accessible from the inverter keypad interface. Inverter parameter H30 and digital input signal LE must be enabled to operate the inverter from the Modbus interface. If LE is not assigned to a digital input (X1-X9), the signal will default to ON.

Frequency Setting Registers

Address	Code	Name	Unit	Variable Range	Min. unit	Read/Write	Data Format
1793	S01	Frequency command	-	-20000–20000 (max. frequency at ± 20000)	1	R/W	2
1797	S05	Frequency command	Hz	0.00–400.00	0.01	R/W	5

Note:

- 1) If both S01 and S05 are set, the inverter will ignore the setting of S05.
- 2) A data setting that exceeds the setting range is possible, but the actual action will be limited by the inverter configuration.

Operation command data Registers

Address	Code	Name	Unit	Variable Range	Min. unit	Read/Write	Data Format
1798	S06	Operation command	-	Refer to the data format [14]	-	R/W	14
1799	S07	Universal Do	-	Refer to the data format [15]	-	R/W	15
1804	S12	Universal Ao	-	-20000–20000 (100% output at ± 20000)	1	R/W	2

Note:

- 1) Since X1–X9 are configurable input commands, it is necessary to set the functions by E01–E09.
- 2) The alarm reset is executed, when RST signal changes from ON to OFF even if there are no alarms.
- 3) Universal Do is a function that utilizes the inverter’s digital outputs via communication.

Function data Registers

Address	Code	Name	Unit	Variable Range	Min. unit	Read/Write	Data Format
1800	S08	Acceleration time F07	s	0.1–3600.0	0.1	R/W	3
1801	S09	Deceleration time F08	s	0.1–3600.0	0.1	R/W	3
1802	S10	Torque limit level 1 (driving) F40	%	20.00–200.00, 999 (P11S:20.00-150.00)	1.00	R/W	5
1803	S11	Torque limit level 2 (braking) F41	%	0.00, 20.00–200.00, 999 (P11S:20.00-150.00)	1.00	R/W	5

Note:

- 1) The writing of data out of range is treated as out of range error.
- 2) Use a value of 7FFF_H to enter 999 for torque limit functions.

Monitoring parameter registers

Address	Code	Description	Unit	Range	Min. unit	Read/Write	Data Format
2049	M01	Frequency command (final command)	-	- 20000–20000 (max. frequency at \pm 20000)	1	R	[2]
2053	M05	Frequency command (final command)	Hz	0.00–400.00 (P11S:0.00-120.00)	0.01	R	[5]
2054	M06	Actual frequency	-	- 20000–20000 (max. frequency at \pm 20000)	1	R	[2]
2055	M07	Actual torque value	%	- 200.00–200.00	0.01	R	[6]
2056	M08	Torque current	%	- 200.00–200.00	0.01	R	[6]
2057	M09	Output frequency	Hz	0.00–400.00 (P11S:0.00-120.00)	0.01	R	[5]
2058	M10	Motor output (input electric power)	%	0.00–200.00	0.01	R	[5]
2059	M11	Output current r. m. s.	%	0.00–200.00 (inverter rating at 100.00)	0.01	R	[5]
2060	M12	Output voltage r. m. s.	V	0.0–600.0	1.0	R	[3]
2061	M13	Operation command (final command)	-	Refer to data format [14]	-	R	[14]
2062	M14	Operating state	-	Refer to data format [16]	-	R	[16]
2063	M15	Universal output terminal data	-	Refer to data format [15]	-	R	[15]
2064	M16	Fault memory 0	-	Refer to data format [10]	-	R	[10]
2065	M17	Fault memory 1					
2066	M18	Fault memory 2					
2067	M19	Fault memory 3					
2068	M20	Integrated operating time	h	0–65535	1	R	[1]
2069	M21	DC link voltage	V	0–1000	1	R	[1]
2071	M23	Type code	-	Refer to data format [17]	-	R	[17]
2072	M24	Inverter capacity code	-	Refer to data format [11]	-	R	[11]
2073	M25	ROM version	-	0–64999	1	R	[1]
2074	M26	Transmission error processing code	-	Refer to data format [20]	-	R	[20]
2075	M27	Frequency command at alarm (final command)	-	- 20000–20000 (max. frequency at \pm 20000)	1	R	[2]
2079	M31	Frequency command at alarm (final command)	Hz	0.00–400.00 (P11S:0.00-120.00)	0.01	R	[5]
2080	M32	Actual frequency at alarm	-	- 20000–20000 (max. frequency at \pm 20000)	1	R	[2]
2081	M33	Actual torque at alarm	%	- 200.00 – 200.00	0.01	R	[6]
2082	M34	Torque current at alarm	%	- 200.00 – 200.00	0.01	R	[6]
2083	M35	Output frequency at alarm	Hz	0.00 – 400.00 (P11S:0.00-120.00)	0.01	R	[5]
2084	M36	Motor output at alarm (input power)	%	0.00–200.00	0.01	R	[5]
2085	M37	Output current r.m.s. at alarm	%	0.00 – 200.00 (inverter rating at 100.00)	0.01	R	[5]
2086	M38	Output voltage effective value at alarm	V	0.0 – 600.0	1.0	R	[3]
2087	M39	Operation command at alarm	-	Refer to data format [14]	-	R	[14]
2088	M40	Operating state at alarm	-	Refer to data format [16]	-	R	[16]
2089	M41	Universal output terminal data at alarm	-	Refer to data format [15]	-	R	[15]
2090	M42	Integrated operation time at alarm	h	0–65535	1	R	[1]
2091	M43	DC link voltage at alarm	V	0–1000	1	R	[1]
2092	M44	Inverter internal air temp.at alarm	°C	0–120	1	R	[1]
2093	M45	Cooling fin temp. at alarm	°C	0–120	1	R	[1]
2094	M46	Life of main circuit capacitor.	%	0.0–100.0	0.1	R	[3]
2095	M47	Life of printed circuit board capacitor.	h	0–65535	1	R	[1]
2096	M48	Life of cooling fan.	h	0–65535	1	R	[1]

9-4-7 Data Format Specification

All data in the data field of communication frame shall be represented by a 16 bit length word.

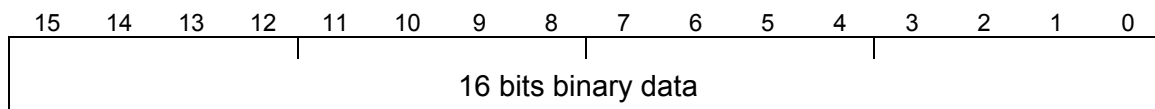

Data format [1] Unsigned Integer data (Positive): Min. unit 1
Example If F15 (Frequency limit, upper)= 60Hz
 $60 = 003C_H$

Data format [2] Integer data (Positive, negative): Min. unit 1
Example data = -20
 $-20 = FFEC_H$

Data format [3] Unsigned Decimal data (Positive): Min. unit 0.1
Example: If F17 (frequency gain setting signal) = 100.0%
 $100.0 \times 10 = 1000 = 03E8_H$

Data format [4] Decimal data (Positive, negative): Min. unit 0.1
Example If: C31 (Analog input offset adjust, terminal12) = - 5.0%
 $- 5.0 \times 10 = - 50 = FFCE_H$

Data format [5] Unsigned Decimal data (Positive): Min. unit 0.01
Example: If C05 (multi-step frequency 1) = 50.25Hz
 $50.25 \times 100 = 5025 = 13A1_H$

Data format [6] Decimal data (Positive, negative): Min. unit 0.01
Example: If M07 (actual torque value)= - 85.38%
 $- 85.38 \times 100 = - 8538 = DEA6_H$

Data format [7] Unsigned Decimal data (Positive): Min. unit 0.001
Example: If o05 (follow - up side ASR 1 constant) = 0.105s
 $0.105 \times 1000 = 105 = 0069_H$

Data format [8] Decimal data (Positive, negative): Min. unit 0.001
Example: Data = -1.234
 $- 1.234 \times 1000 = - 1234 = FB2E_H$

Data format [9] Unsigned Integer data (Positive): Min. unit 2
Example If P01 (Motor 1 number of poles) =2pole
 $2 = 0002_H$

Data format [10]

Alarm Code

Code	Description		Code	Description	
0	No alarm	-	22	Overheat, DB resistor	dbH
1	Overcurrent, during acceleration (INV output)	OC1	23	Overload, motor 1	OL1
2	Overcurrent, during deceleration (INV output)	OC2	24	Overload, motor 2	OL2
3	Overcurrent, during steady state operation (INV output)	OC3	25	Overload, inverter	OLU
5	Ground fault	EF	27	Overspeed	OS
6	Overvoltage, during acceleration	OU1	28	PG wire break	Pg
7	Over voltage, during deceleration	OU2	31	Memory error	Er1
8	Overvoltage, during steady state operation	OU3	32	Keypad error	Er2
10	DC undervoltage	LU	33	CPU error	Er3
11	Power supply open phase	Lin	34	Option comm. error	Er4
14	Blown DC fuse	FUS	35	Option error	Er5
16	Output wiring error	Er7	36	PL error	Er6
17	Overheat, heat sink, inverter	OH1	37	Output wiring error	Er7
18	Overheat, outside thermal	OH2	38	RS-485 comm. error	Er8
19	Overheat, unit inside temp.	OH3			

Data format [11]

Capacity code

Code	Capacity (HP)	Code	Capacity (HP)	Code	Capacity (HP)
7	0.07(spare)	2000	20	17500	175
15	0.15(spare)	2500	25	20000	200
25	0.25	3000	30	25000	250
50	0.5	4000	40	30000	300
100	1	5000	50	35000	350
200	2	6000	60	40000	400
300	3	7500	75	45000	450
500	5	10000	100	50000	500
750	7.5	12500	125	60600	600
1000	10	15000	150	60700	700
1500	15			60800	800

Data format [12]

Index data (ACC/DEC time, display coefficient)

15	14	13	12	11	10	9	8	7	6	5	4	3	2	1	0
Polarity	0	0	0	Index portion			Data portion								
0: Positive (+),			0: 0.01	X						001-999			(0.00-9.99)		
			1: 0.1	X						100-999			(10.0-99.9)		
1: Negative (-)			2: 1	X						100-999			(100-999)		
			3: 10	X						100-999			(1000-9990)		

Example: If F07 (acceleration time 1) = 20.0 s

10.0 < 20 < 99.9 → index = 1

20.0 = 0.1 X 200 → 0400_H + 00C8_H = 04C8_H

Data format [13]

Pattern operation

15	14	13	12	11	10	9	8	7	6	5	4	3	2	1	0
Direction of rotation	0	Time		Index portion											

	0: 1st ACC/DEC time	0: 0.01	X		001–999	(0.00–9.99)
0: FWD	1: 2nd ACC/DEC time	1: 0.1	X		100–999	(10.0–99.9)
1: REV	2: 3rd ACC/DEC time	2: 1	X		100–999	(100–999)
	3: 4th ACC/DEC time	3: 10	X		100–999	(1000–9990)

Example) If C22 (Stage1) = 10.0s R2 (10s, reverse rotation, acceleration time 2/deceleration time 2)
 Since $10.0 = 0.1 \times 100 > 9000_H + 0400_H + 0064_H = 9464_H$

Data format [14]

Operation command

15	14	13	12	11	10	9	8	7	6	5	4	3	2	1	0
RST	0	0	0	0	X9	X8	X7	X6	X5	X4	X3	X2	X1	REV	FWD

(All bit are ON by 1)

Example) If S06 (operation command) = FWD, X1 and X5 = ON
 $0000\ 0000\ 0100\ 0101_b = 0045_H$

Data format [15]

Universal output terminal

15	14	13	12	11	10	9	8	7	6	5	4	3	2	1	0
0	0	0	0	0	0	0	0	0	0	0	Y5	Y4	Y3	Y2	Y1

(All bit are ON by 1)

Example) If M15 (Universal output terminal)=Y1 and Y5 = ON
 $0000\ 0000\ 0001\ 0001_b = 0011_H$

Data format [16]

Operating state

15	14	13	12	11	10	9	8	7	6	5	4	3	2	1	0
BUSY	WR	RL	ALM	DEC	ACC	IL	VL	TL	NUV	BRK	INT	EXT	REV	FWD	

(All bit are ON or active by 1)

- | | |
|---|--------------------------------|
| FWD: Forward operation | IL: Current limiting |
| REV: Reverse operation | ACC: Under acceleration |
| EXT: DC braking active (or pre-excitation) | DEC: Under deceleration |
| | ALM: Inverter fault |
| INT: No Output | RL: Transmission valid |
| BRK: Braking active | WR: Function writing privilege |
| NUV: DC link voltage is established (undervoltage at 0) | 0: Keypad panel |
| | 1: RS-485 |
| TL: Torque limiting | 2: Fieldbus (option) |
| VL: Voltage limiting | BUSY: Processing data write |

Data format [17]

Type code

15	14	13	12	11	10	9	8	7	6	5	4	3	2	1	0
Type				Generation				Series				Voltage series			

Code	Type	Generation	Series	Voltage series
1	-	G11/P11	-	-
2	G	-	-	-
3	P	-	-	230V three phase
4	-	-	-	460V three phase
5	-	-	USA	575V three phase
6	-	-	-	-

Data format [18]

Code setting (1–4 figures)

15	14	13	12	11	10	9	8	7	6	5	4	3	2	1	0
Data 4				Data 3				Data 2				Data 1			

Data format [19]

Amperage value Decimal data (positive):
 Min. unit 0.01 inverter capacity is not more than 30HP
 Min unit 0.01 for not less than 40HP

Example) If F11 (electronics thermal overload relay 1 level)107.0A (40HP)
 $107.0 \times 10 = 1070 = 042E_H$
 If F11 (electronics thermal overload relay 1 level)=3.60A (1HP)
 Since $3.60 \times 100 = 360 = 0168_H$

Data format [20]

Transmission error code

Code	Description	Code	Description
1	FC (function code) error	71	CRC error (no response)
2	Illegal address	72	Parity error (no response)
3	Illegal address (Data range error)	73	Other errors (no response) -Framing error -Overrun error -Buffer full error
7	NAK -Priority for comm. -No privilege for writing error -Forbidden writing error		

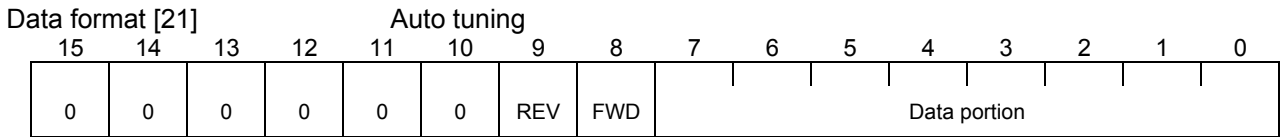

0: Without forward rotation command
 1: With forward rotation command.
 0: Without reverse rotation command.
 1: With reverse rotation command.

Example) If P04 (motor 1 auto - tuning)=1: Forward rotation
 0000 0001 0000 0001_b=0101_H

9-4-8 Communication Errors

Exception Response

When the inverter receives a message that does not contain communication errors but the message can not be processed, the inverter will return an exception response. The exception response contains an error sub-code in the data field that represents the problem.

Exception Response Errors

Sub-Code	Name	Causes
1	Illegal Function	Received RTU Function other than 03, 06 or 16
2	Illegal Data Address	<ul style="list-style-type: none"> • The starting parameter address is an unused inverter parameter. • The starting parameter address plus the offset refers to inverter parameter greater than the last parameter in a Function Code sort. • The number of registers is greater than 16.
3	Illegal Data Value	Data contains an out of range value for an inverter parameter
7	Negative Acknowledge	<ul style="list-style-type: none"> • Requested data cannot be changed while the inverter is running. • The inverter parameter function is owned by the network interface option card and cannot be changed.

Communication errors

Communication errors occur when the inverter receives an invalid message. The inverter will not return a response to a communication error. A code that represents the last communication error is stored in inverter parameter M26. Typical communication message errors include parity, framing, and CRC errors.

10. Options

10-1 Built-in Options

The inverter supports two internally mounted cards. One option card is mounted under the main cover (Location A) and the other option card is mounted in a special adapter under the keypad (Location B). Only one card can be mounted in these locations. There are two different types of option cards, Type 1 and Type 2. You cannot use two Type 1 or Two Type 2 cards but you can mix any combination of Type 1 and Type 2 provided you only have one option per mounting location. Each option card must be mounted in the designated location. The chart below lists the option card, their types, and their mounting locations.

Name	Type	Loc	2nd Option Type/Loc	Function
OPC-G11S-RY (Relay output card)	1	A	2/B	<ul style="list-style-type: none"> Relay output card The transistor output from the inverter control output terminals Y1 and Y4 are converted to the relay output (1SPDT).
OPC-G11S-DIO (Digital interface card)	2	A	None	<ul style="list-style-type: none"> Frequency setting by binary code (max. 16 bits) Monitoring (8 bits) of frequency, output current, and output voltage
OPC-G11S-AIO (Analog interface card)	2	A	None	<ul style="list-style-type: none"> Auxiliary input for analog frequency setting (0 to +/-10 V) Monitoring of inverter output frequency, current, and torque in analog voltage, analog output 0-10 VDC and 4-20mA
OPC-G11S-PG (PG Feedback Card) (G11S only)	1	A	2/B	<ul style="list-style-type: none"> This will enable vector control by pulse generator feedback signal Proportional operation, tuning operation (12/15 V; A, B Signal)
OPC-G11S-PG2 (PG Feedback Card) (G11S only)	1	A	2/B	<ul style="list-style-type: none"> This will enable vector control by pulse generator feedback signal Proportional operation, tuning operation (5V; A, not A, B, not B Signals)
OPC-G11S-SY (Synchronized operation card) (G11S only)	1	A	2/B	<ul style="list-style-type: none"> Two motors are driven synchronously.
OPC-G11S-PDP (Communication card)	2	B	1/A	<ul style="list-style-type: none"> Serial communication card for Profibus-DP
OPC-G11S-DEV (Communication card)	2	B	1/A	<ul style="list-style-type: none"> Serial communication card for Device Net
OPC-G11S-COP (Communication card)	2	B	1/A	<ul style="list-style-type: none"> Serial communication card for CAN
OPC-G11S-MBP (Communication card)	2	B	1/A	<ul style="list-style-type: none"> Serial communication card for Modbus plus
OPC-G11S-IBS (Communication card)	2	B	1/A	<ul style="list-style-type: none"> Serial communication card for Interbus-S

10-2 Separately Installed Options

Name (Type)	Explanation	Installation Position
Arrester (CN23232) (CN2324E)	Absorbs power surges from the power source and protects the whole equipment connected to the power source.	
EMC compliance filter (FS5536-□□-07) (EFL-□□SP-2) (EFL-□□G11-4) (RF3□□□-F11)	An exclusive filter to conform to the EMC Directive (emissions) in European standard. Note: Refer to the "Installation Manual" when installing the filter.	
Output circuit filter (OFL-□□□-2) (OFL-□□□-4) (OFL-□□□-4A)	Connected to the output circuit of the low-noise type inverter (Carrier frequency :8kHz to 15kHz, 6kHz when exceeding 40HP) and used for the following purposes. ① Voltage vibration suppression at the motor terminals. Prevent damage to the motor insulation by surge voltage for the 460V series inverter. ② Leakage current reduction on the output side wiring. Reduce leakage current by parallel operation by multiple motors or long-distance wiring. - Length of wiring should be 1300ft (400m) or less. ③ To reduce induced noise and radiating noise from output wiring. Effective in long-distance wiring such as plant lines. Note 1 : When OFL-□□□-2 or OFL-□□□-4 is connected, the setting value of the carrier frequency (F26) should be set to 8kHz or more. (6kHz or more when exceeding 40HP.) Note 2 : There is no restriction of carrier frequency (F26) when connecting the OFL-□□□-4A.	
DC reactor (DCR2-□□□) (DCR4-□□□)	(For power coordination) ① Used when the capacity of the power supply transformer exceeds 500kVA and exceeds the rated capacity of the inverter tenfold. ② Used when a thyristor converter is connected as a common load on the same transformer. - If the commutating reactor is not used for the thyristor converter, an AC reactor is necessary at the inverter input side. Confirm. ③ Used to prevent an inverter OV trip from occurring when the phase advanced capacitor in the power line is switched on and off. ④ Used when the voltage imbalance exceeds 2%. $\text{Voltage unbalance [\%]} = \frac{(\text{Max. Voltage [V]} - \text{Min. Voltage [V]})}{3\text{-phase average voltage [V]}} \times 67\%$ <p>Power supply capacity</p> <p>DC reactor</p> <p>Inverter</p> <p>Commutating reactor</p> <p>Thyristor converter</p> <p>Series connected reactor</p> <p>Power-factor improving capacitor</p> <p>(For improving the input power-factor and reducing harmonics) Used to reduce the harmonic current (improvement of power-factor). * For details on the degree of reduction, see the materials attached to the guidelines, etc.</p>	
Surge suppressor (SZ-Z□)	For magnetic contactor [Product of Fuji Electric Technica Co., Ltd.]	
Frequency meter (TRM-45)(FM-60)	Analog frequency meter (45, 60 square) [Product of Fuji Electric Technica Co., Ltd.]	
Frequency setting device (VR) (RJ-13BA-2)(WA3W-1kΩ)	Frequency setting variable resistor [Product of Fuji Electric Technica Co., Ltd.]	

11. Electromagnetic compatibility (EMC)

11-1 General

In accordance with the provisions described in the European Commission Guidelines Document on Council Directive 89/336/EEC, Fuji Electric Co., Ltd. has chosen to classify the FRENIC 5000G11S range of Inverters as "Complex Components".

Classification as a "Complex Components" allows a product to be treated as an "apparatus", and thus permits compliance with the essential requirements of the EMC Directive to be demonstrated to both an integrator of FRENIC Inverters and to his customer or the installer and the user.

FRENIC Inverters is supplied 'CE-marked', signifying compliance with EC Directive 89/336/EEC when fitted with specified filter units installed and earthed in accordance with this sheet.

This Specification requires the following performance criteria to be met.

EMC product standard **EN61800-3/1997 +A11/2000**

Immunity : **Second environment** (Industrial environment)

Emission : **First environment** (Domestic environment)

Distribution class of Emission

Unrestricted distribution	Restricted distribution
<u>Without OPC-G11S-***</u> FRN020G11S-4UX or less. FRN025P11S-4UX or less.	<u>Without OPC-G11S-***</u> FRN025G11S-4UX or more. FRN030P11S-4UX or more. FRN-G11S/P11S-2UX
	<u>With OPC-G11S-***</u> FRN-G11S-2UX/4UX all models with OPC-G11S-***. Card option : OPC-G11S-AIO, DIO, PG, PGA, PG2, SY, RY, PGDIO, PGRY, TL Bus option : OPC-G11S-PDP, DEV, MBP, IBS, COP
	WARNING This is a product of the restricted sales distribution class according to IEC61800-3. In a domestic environment this product may cause radio interference in which case the user may be required to take adequate measures.

Finally, it is customer's responsibility to check whether the equipment conforms to EMC directive.

11-2 Recommended Installation Instructions

It is necessary that to conformed to EMC Directive, these instructions must be followed.

Follow the usual safety procedures when working with electrical equipment. All electrical connections to the filter, Inverter and motor must be made by a qualified electrical technician.

- 1) Use the correct filter according to Table 11-1.
- 2) Install the Inverter and filter in the electrically shielded metal wiring cabinet.
- 3) The back panel of the wiring cabinet of board should be prepared for the mounting dimensions of the filter. Care should be taken to remove any paint etc. from the mounting holes and face area of the panel. This will ensure the best possible earthing of the filter.
- 4) Use the screened cable for the control , motor and other main wiring which are connected to the Inverter, and these screens should be securely earthed.
- 5) It is important that all wire lengths are kept as short as possible and that incoming mains and outgoing motor cables are kept well separated.

" To minimize the conducted radio disturbance in the power distribution system, the length of the motor-cable should be as short as possible. "

Table 11-1 RFI filters

Applied Inverter	Filter Type	Rated Current	Max. Rated Voltage	RFI filter		
				Dimensions LxWxH [inch (mm)]	Mount Dims Y x X [inch (mm)]	Note
FRNF50G11S-4UX FRN001G11S-4UX	FS5536-5-07 (EFL-0.75G11-4)	5A	3ph 480Vac	12.6(320) × 4.57(116) × 1.65(42)	11.5(293) × 3.54(90)	Fig. 11-1
FRN002G11S-4UX FRN003G11S-4UX FRN005G11S-4UX	FS5536-12-07 (EFL-4.0G11-4)	12A		12.6(320) × 6.10(155) × 1.77 (45)	11.5(293) × 4.13(105)	
FRN007G11S/P11S-4UX FRN010G11S/P11S-4UX	FS5536-35-07 (EFL-7.5G11-4)	35A		13.4(341) × 8.86(225) × 1.87(47.5)	12.2(311) × 6.57(167)	
FRN015G11S/P11S-4UX FRN020G11S/P11S-4UX	FS5536-50-07 (EFL-15G11-4)	50A		19.7(500) × 9.84(250) × 2.76(70)	17.7(449) × 7.28(185)	
FRN025G11S/P11S-4UX FRN030G11S/P11S-4UX	FS5536-72-07 (EFL-22G11-4)	72A		19.7(500) × 9.84(250) × 2.76(70)	17.7(449) × 7.28(185)	
FRN040G11S/P11S-4UX FRN040G11S/P11S-4UX	RF 3100-F11	100A	3ph 480Vac	17.1(435) × 7.87(200) × 5.12(130)	16.0(408) × 6.54(166)	Fig. 11-2
FRN050G11S/P11S-4UX FRN060G11S/P11S-4UX FRN075G11S/P11S-4UX FRN100G11S/P11S-4UX FRN125G11S/P11S-4UX	RF 3180-F11	180A		19.5(495) × 7.87(200) × 6.30(160)	18.4(468) × 6.54(166)	
FRN150G11S/P11S-4UX FRN200G11S/P11S-4UX	RF 3280-F11	280A		9.84(250) × 23.11(587) × 8.07(205)	22.1(560) × 3.35(85)	Fig. 11-3
FRN250G11S/P11S-4UX FRN300G11S/P11S-4UX FRN350G11S/P11S-4UX	RF 3400-F11	400A		9.84(250) × 23.11(587) × 8.07(205)	22.1(560) × 3.35(85)	
FRN400G11S/P11S-4UX FRN450G11S/P11S-4UX	RF 3880-F11	880A		27.1(688) × 14.33(364) × 7.09(180)	25.5(648) × 5.91(150)	Fig. 11-4

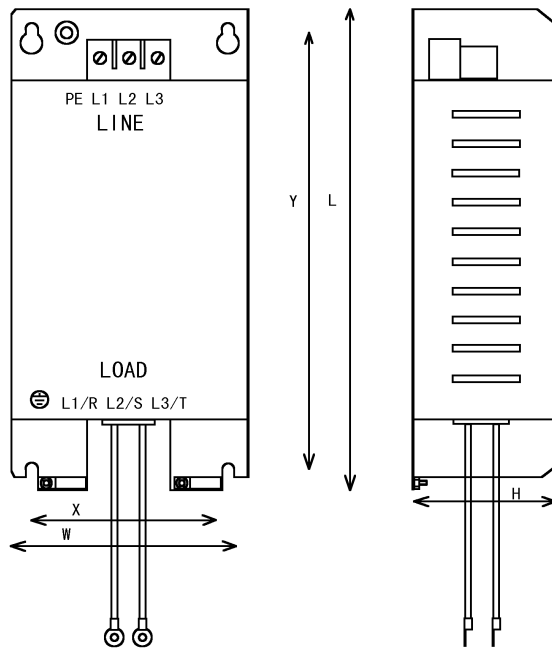
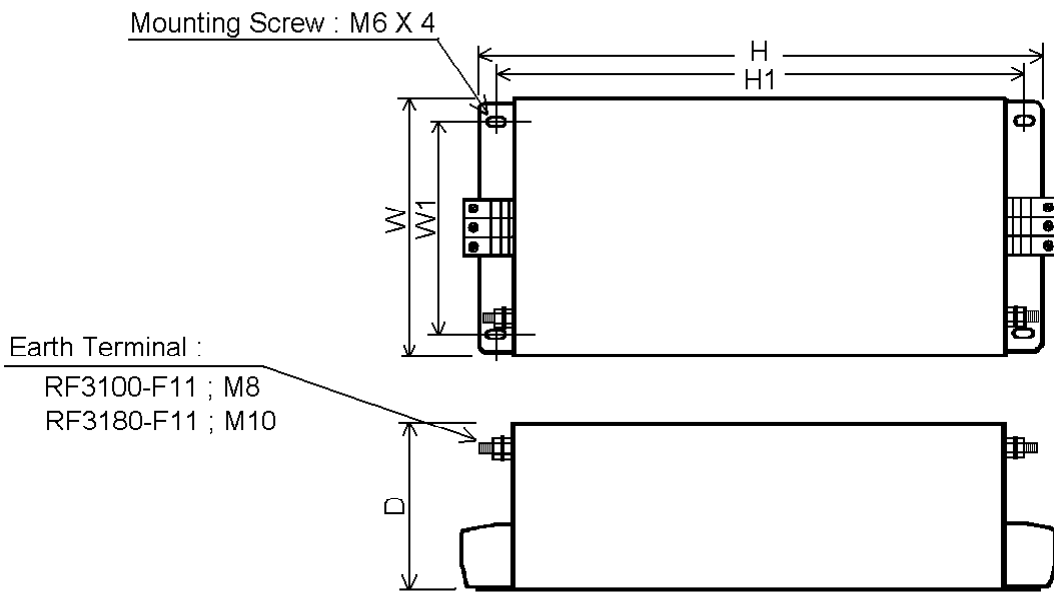

Fig.11-1



	Dimensions [inch(mm)]				
	W	W1	H	H1	D
RF3100-F11	7.87 (200)	6.54 (166)	17.1 (435)	16.1 (408)	5.12 (130)
RF3180-F11	7.87 (200)	6.54 (166)	19.5 (495)	18.4 (468)	6.30 (160)

Fig.11-2 Outline Dimensions (RF3100-F11, RF3180-F11)

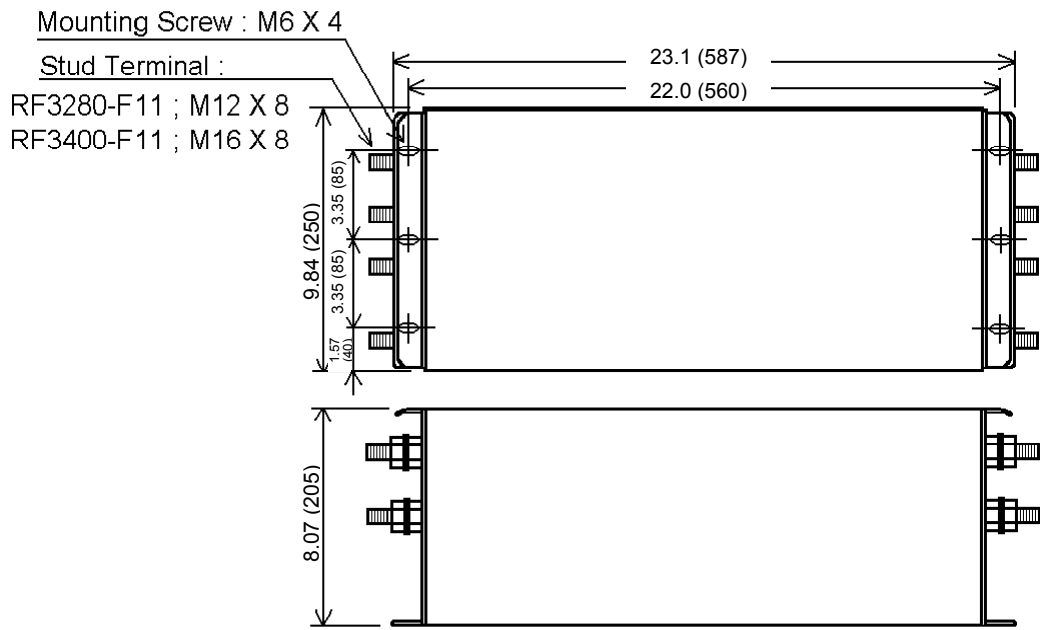

Fig.11-3 Outline Dimensions (RF3280-F11, RF3400-F11)

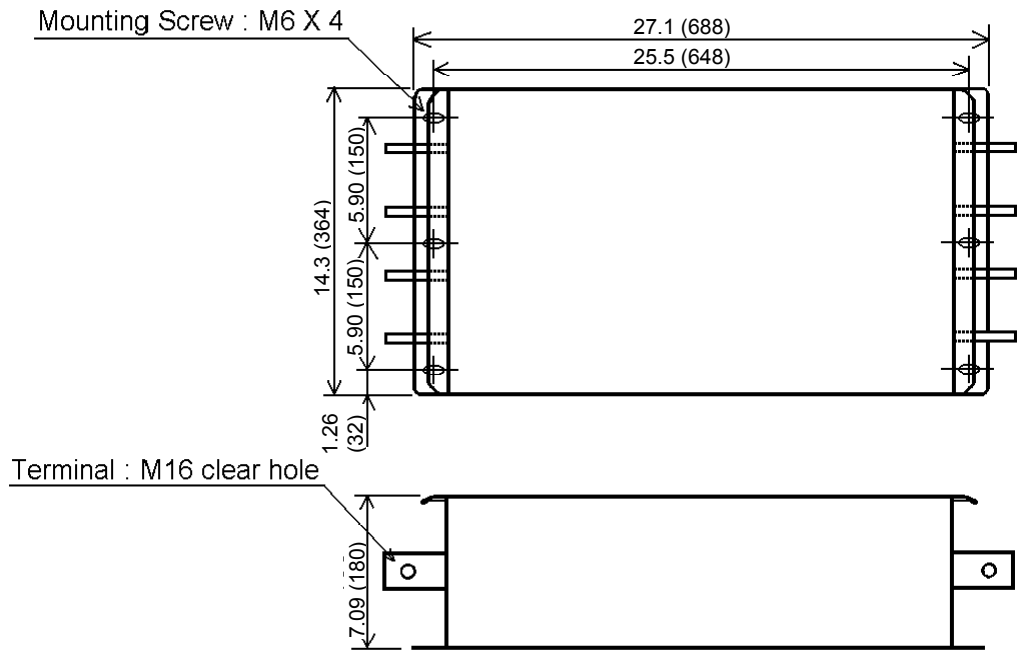

Fig.11-4 Outline Dimensions (RF3880-F11)

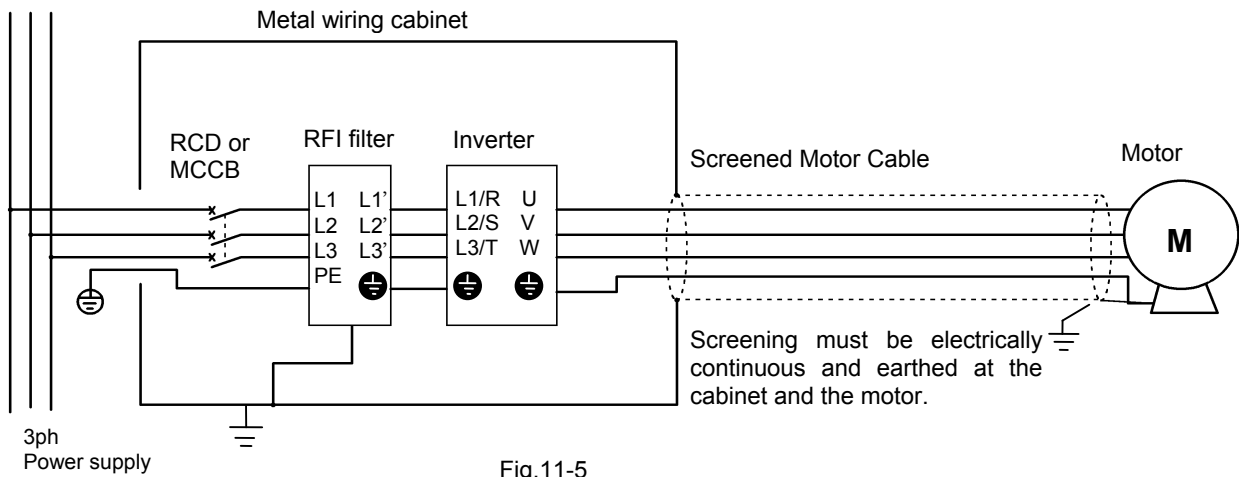

Fig.11-5

11-3 The harmonics restriction in Europe Union (EU)

Combinations of the inverter with DC-reactor in table 11-2 fulfill the harmonics requirements of the EN 61000-3-2(+A14), which are European EN standard.

However these inverters without DC-reactor don't fulfill them. If they shall be connected to the public low voltage power supply system, the supply authority must be asked for permission to connect.

Fuji Electric can provide this data sheets when you need the data for harmonics currents.

Table 11-2

Inverter model name	Applied DC-reactor model name		Power supply
FRNF50G11S-4UX	DCR4-0.4	or DCRE4-0.4	Three-phase 460V
FRN001G11S-4UX	DCR4-0.75	or DCRE4-0.75	

